



ISSN: 2374-2275

ISBN: 978-0-578-62617-8

Organized by the International TRIZ Association – MATRIZ

THE 15th INTERNATIONAL CONFERENCE

TRIZ *fest*-2019

September 11-14, 2019, Heilbronn, Germany

CONFERENCE PROCEEDINGS

Editors: *Valeri Souchkov, Oliver Mayer*



Local Organizer:



Industrie- und Handelskammer
Heilbronn-Franken

Proceedings of the 15th MATRIZ TRIZfest-2019 International Conference

September 11-14, 2019, Heilbronn, Germany.

Organized by the International TRIZ Association – MATRIZ.

Local organizer: Chamber of Commerce and Industry Heilbronn-Franken (IHK), Heilbronn, Germany.

Heilbronn, Germany, 2019.

417 pages.

ISSN: 2374-2275

ISBN: 978-0-578-62617-8

Editors: Valeri Souchkov, TRIZ Master and Prof. Oliver Mayer, TRIZ Master

The collection of papers «Proceedings of the 15th MATRIZ TRIZfest 2019 International Conference».

The conference is intended for TRIZ specialists and users: academics, engineers, inventors, innovation professionals, and teachers.

The present book of Proceedings includes papers related to the research and development of TRIZ, best practices with TRIZ, cases of practical application of TRIZ, and issues of TRIZ training and education.

Series “**Proceedings of the TRIZfest International Conference**”. ISSN: 2374-2275

© Copyright: 2019, International TRIZ Association – MATRIZ.

All rights reserved. No part of this publication may be reproduced, stored in a retrieval system, or transmitted, in any form or by any means, electronic, mechanical, photocopying, recording or otherwise, without the prior permission of the publishers.

Prepared and Published by the International TRIZ Association – MATRIZ, 8946 Wesley Place, Knoxville, TN 37922 USA

www.matriz.org

TRIZfest 2019 ORGANIZING COMMITTEE

Dr. Mark Barkan, TRIZ Master, MATRIZ Executive Director: The Organizing Committee Chair.

Mr. Kai Plambeck, Consultant for Innovation and Networks, Chamber of Commerce and Industry Heilbronn-Franken (IHK): The Organizing Committee Co-Chair.

Dr. Oliver Mayer, TRIZ Master: Co-Chairman of the Program Management Committee.

Mr. Valeri Souchkov, TRIZ Master: Co-Chairman of the Program Management Committee.

Dr. Yury Fedosov, TRIZ Master: MATRIZ President.

Dr. Simon Litvin, TRIZ Master: Chairman of the TRIZ Master Certification Council (TMCC).

Ms. Christiane Heim, Administrator Business Unit Location Policy, Chamber of Industry and Commerce Heilbronn-Franken (IHK): Local Representative.

TRIZfest 2019 PAPERS REVIEW COMMITTEE

Dr. Robert Adunka, TRIZ Master, Germany

Mr. Dmitry Bakhturin, Russia

Dr. Mark Barkan, TRIZ Master, USA

Dr. Tiziana Bertoncelli, Germany

Mr. Christoph Dobrusskin, The Netherlands

Dr. Ellen Domb, USA

Mr. Lorenzo Duroux, France

Dr. Marco Aurelio Carvalho, Brazil

Dr. Victor Fey, TRIZ Master, USA

Dr. Oleg Feygenson, TRIZ Master, South Korea

Dr. Marta Gardner, USA

Ms. Barbara Gronauer, Germany

Dr. Karl Koltze, Germany

Dr. Pavel Livotov, Germany

Mr. Alex Lyubomirskiy, TRIZ Master, USA

Dr. Oliver Mayer, TRIZ Master, Germany

Mr. Horst Naehler, Germany

Dr. Toru Nakagawa, Japan

Mr. Alexey Pinyaev, TRIZ Master, USA

Mr. Tanasak Pheunghua, Thailand

Mr. Valeriy Prushinskiy, TRIZ Master, USA

Dr. Runhua Tan, People Republic of China

Mr. Valeri Souchkov, TRIZ Master, The Netherlands

Dr. Christian M. Thurnes, Germany

Dr. Tom Vaneker, The Netherlands

Dr. TS Yeoh, Malaysia

Mr. Hongyul Yoon, TRIZ Master, South Korea

Dear colleagues and friends,

It is my honor and privilege to welcome you to the annual 15th TRIZfest conference in Germany.

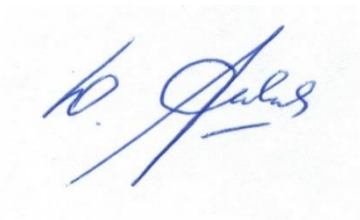
This country is one of the leaders in the field of technological progress, a country of high engineering culture.

The TRIZfest-2019 has a very rich and varied program. TRIZ practitioners from many countries will share their results in the development of the TRIZ methodology, the success of TRIZ industrial applications, the use of TRIZ in education, in schools, etc. The conference presents both experts in the field of science and education, as well as talented engineers from the most creative companies in the world.

I would like to note and appreciate the high level of the conference organization. This was made possible thanks to the high qualifications and hard work of the members of the Organizing and Program Committees.

I am sure that the diverse and extensive experience of the conference participants, the vast geography - there are speakers from Europe, Asia and America, the passion and dedication of the participants to innovations and TRIZ will make the conference creative, enjoyable and useful.

I wish you all productive discussions, useful contacts, interesting discoveries and a wonderful pastime in Heilbronn!



Dr. Yury Fedosov, TRIZ Master
MATRIZ President

Dear Participants,

The Heilbronn-Franken Chamber of Commerce and Industry would like to thank MATRIZ and the members of the board for choosing Heilbronn as the venue for their events following Prague, Seoul, Beijing, Krakow and Lisbon. We are honored to be the host of this year's international conference and pleased to welcome some of the world's best developers.

As a Chamber of Commerce and Industry we are responsible for 72,000 member companies. And we support them in issues ranging from cradle to cradle, represent the interests of the members vis-à-vis politics and carry out sovereign tasks.

We are located in one of the economically strongest and most dynamic regions, have the highest density of world market leaders in Germany with a great variety of industries, which you can reach all by car within an hour.

Innovations are vital for the survival of companies and TRIZ is a good way to produce radical innovations. Since 2006, the IHK has been supporting a TRIZ user group consisting of developers from the member companies who meet once a month to solve tasks with TRIZ.

I wish the event a good course and inspiring conversations, interesting lectures and a good stay.



Prof. Dr. Dr. h.c. Harald Unkelbach

President of the Heilbronn-Franken Chamber of Commerce and Industry

Dear TRIZfest 2019 Participants and Readers,

It is a pleasure to announce the 15th International Conference “TRIZfest 2019” which will be held on September 11-14, 2019 in Heilbronn, Germany.

Germany is a country famous for its long-term achievements in the areas of engineering and technology. Many breakthrough inventions and innovations have been produced by German engineers and inventors. Germany established very solid background in academic research on engineering and innovation including a systematic approach to conceptual engineering design. Needless to say, Germany was one of the first countries which started to introduce TRIZ when it was brought to the world. It all makes us proud to have our conference in the country.

This year the conference includes papers and presentations focused on the following topics:

- Theoretical, research results.
- TRIZ-related methods and tools development.
- Best practices, business experiences, integration with non-TRIZ methods/tools.
- TRIZ-Pedagogy
- Educational methods and experiences.
- Case studies.

TRIZfest 2019 will continue its special section “TRIZ-Pedagogy” and introduce panel discussions on several important topics regarding TRIZ and its applications.

We would like to thank all the authors and co-authors who contributed their works to include to these Proceedings and therefore provided considerable impact on further development of TRIZ and its dissemination around the world.

We would like to express our sincere gratitude to all the members of the TRIZfest 2019 Organizing Committee who provided their help and support as well as to the members of the Papers Review Committee who invested their precious time to select the best papers and provide authors with comments how to improve their papers.

And at last but not least, we would like to express thanks to Chamber of Commerce and Industry of Heilbronn-Franken (IHK) and all enthusiastic partners of MATRIZ in Germany who invested their efforts to make the event possible.



A handwritten signature in blue ink, appearing to read 'Souchkov'.

Valeri Souchkov, TRIZ Master
Co-Chair of the TRIZfest 2019
Program Committee
Enschede, The Netherlands



A handwritten signature in black ink, appearing to read 'O. Mayer'.

Dr. Oliver Mayer, TRIZ Master
Co-Chair of the TRIZfest 2019
Program Committee
Munich, Germany

TABLE OF CONTENTS

Sorted alphabetically

Welcome Addresses	5
KEYNOTE PAPER	
The TRIZ based invention process in the knowledge – creativity – abstraction - sphere of disruptive innovations. A practical report by the example of the Galaxie Getriebes® of the WITTENSTEIN SE	12
<i>Thomas Bayer</i>	
CONFERENCE PAPERS	
Algorithm of Enhanced Function-Oriented Search	23
<i>Stéphane Savelli, Oleg Feygenson</i>	
An Analysis of 40 Years Teaching Enlarged TRIZ in Vietnam	35
<i>Minh-Dang Doan</i>	
Application of Systematic Innovation Method in BF Hearth Erosion Problem	44
<i>LIU Yongmou, Zhong Xingli</i>	
Application of TRIZ Techniques for Identifying Ideas for Digital Anti-Trolling	52
<i>Hiltmann Nadiya, Hiltmann Kai</i>	
Applying of Hybridization for Development of Flexible Display Device (Case Study is Based on US984193, EP3306439 and US D819630)	60
<i>Valeriy Prushinskiy</i>	
Big Data Analysis: a Resource to be Considered in TRIZ	70
<i>Oliver Mayer, Tiziana Bertocelli</i>	
Competency-based approach in “education without lesson” at school using the system approach	80
<i>Gredynarova Elena</i>	
Deriving Quantitative Characteristics From CECA Model	89
<i>Jerzy Chrzęszcz</i>	

Design of Robot Self-Cleaning Vision System Based on TRIZ and Multi-Coupling Biomimetic Technology	100
<i>Junlong Chen, He XU, Vishwanath Pooneeth, Zitong Zhao, Xueshan Zhou, Haihang Wang, Feng Sun</i>	
Design of Variable Diameter Flexible Arm Based On TRIZ Theory and Bionics	112
<i>Fengshu Yu, He Xu, Feng Sun, Peng Li</i>	
Extending the Concept of Contradictions – TRIZ Application in Non-Technical / Management -Related Contexts	123
<i>Boris Oliver Kneisel</i>	
Extension of Function Modeling to Non-Technical Systems	130
<i>Valeri Souchkov</i>	
Evolution Analysis and Prediction of Shower	138
<i>Kai Zhang, Yue Lin</i>	
Experience of Large Holding Companies: Internal TRIZ Trainers Education	150
<i>Elena V. Redkolis</i>	
Flow Enhancement Interpretation Experience	160
<i>Michael Schoewel</i>	
FOS with Operating Time	168
<i>Jungin Kim, Yusin Han, Ahreum Lee, Gukhyun Cho, Wanseok Jeong</i>	
Forecasting Digital Radiology Medical Devices	175
<i>Srinivas Peddi</i>	
Function Analysis for Convert System	185
<i>Yong Joon Lee</i>	
How to Bring the Successful Concept of TRIZ to Small and Medium-Sized Companies and to Support Them During the Implementation of TRIZ	192
<i>Stefan Engelhard, Anne-Kathrin Kiesel, Robert Adunka</i>	
Increasing of Customer Experience with Vacuum Cleaner Using the Trends of Engineering System Evolution	198
<i>Vladimir Sizikov, Markus Gabor</i>	

Innovative Design of the Anti-Erosion Structure in a Water Hydraulic Valve Based on TRIZ Combining with Bionics and Fractal Theory	206
<i>Yonghui Zhang, He Xu, Haihang Wang, Siqing Chen, Zitong Zhao, Vishwanath Pooneeth</i>	
Interview Lesson	218
<i>Evgenia Guin, Anatoly Guin</i>	
Logical Negation in CECA Model	223
<i>Jerzy Chrzyszcz</i>	
My First Long-Term TRIZ -Based Project in Heilbronn	234
<i>Ahmad-Ramez Kassou</i>	
Patent Circumvention and Portfolio Design Based on Initial Disadvantages Identification and Cause Effect Chain Analysis	242
<i>Yongwei Sun, Yinhua Long, Shaodan Ma</i>	
Playing as a Way to Resolve the Contradictory Demands. Case Studies Review.	248
<i>Jerzy Obojski</i>	
Process Innovation in Packaging Chocolate Cookies	260
<i>Michael Graf</i>	
Physical Contradiction Resolving By Separation of Contradictory Requirements in Space Or Time On Micro-Level	270
<i>Alex Lyubomirskiy</i>	
Stiffness Improvement of Flexible Arm Based On TRIZ Theory	275
<i>Siqing Chen, He Xu, Haihang Wang, Yonghui Zhang, Peng Li, Vishwanath Pooneeth</i>	
Study on Erosion Resistance of Control Valve Cage Based on TRIZ and Bionics	287
<i>Min Cheng, He Xu, Feng Sun, Liye Jiao, Fengshu Yu</i>	
Study on the Tese Application Roadmap under the Strategic Development of S-Curve	297
<i>Zhang Jing, Zhang Xiangmin, Guo Kai</i>	

Talking About the Practical Application of the Standard Solution	309
<i>Xiaofang Su, Na Yu, Feng Qiang, Ye Wang, Li Lv</i>	
Technology Scouting in Chemistry: Roadmap and Case Studies	319
<i>Oleg Abramov, Pavel Fimin, Evgenia Smirnova</i>	
The 3rd European Remote TRIZ Workshop	327
<i>John Cooke, Christoph Dobrusskin, Pascal Sire</i>	
The Barcamp-Format as a Perfect Setting for Inventive Situations – What the First German TRIZ Barcamp Teaches Us About Innovation Challenges	336
<i>Horst Naehler, Barbara Gronauer, Tiziana Bertoncelli, Thomas Nagel</i>	
The Contribution to TRIZ By the Inventor Schools in the GDR	346
<i>Hans-Gert Gräbe</i>	
The Methods of Step Back From Ideal System	354
<i>Ahreum Lee, Jungin Kim, Wansoek Jeong, Gukhyun Cho, Youshin Han</i>	
The World is Dynamic, The Education is Linear	364
<i>Mark Barkan</i>	
Trends in Healthcare	373
<i>Aljoscha Michael Flohr, Stefan Schaper</i>	
TRIZ Roadmap for Identifying Adjacent Markets	382
<i>Oleg Abramov, Alexander Medvedev, Natalia Tomashevskaya</i>	
TRIZ - Time and Fault Tree Analysis with Function Analysis	391
<i>Jochen Wessner</i>	
TRIZ Tools for Disruptive Cost Reduction	399
<i>Simon S. Litvin</i>	
TRIZ Tools for Effective Roadmaps	412
<i>Kirill Domkin, Georgi Severinets, Oleg Gerasimov</i>	

TRIZfest 2019

September 11-14, 2019. Heilbronn, Germany

KEYNOTE PAPER

THE TRIZ BASED INVENTION PROCESS IN THE KNOWLEDGE – CREATIVITY – ABSTRACTION – SPHERE OF DISRUPTIVE INNOVATIONS

A PRACTICAL REPORT BY THE EXAMPLE OF THE GALAXIE GETRIEBES® OF THE WITTENSTEIN SE

Dipl. Ing. (FH) Thomas Bayer

WITTENSTEIN SE, Igersheim, 97999, Deutschland

Abstract

We at WITTENSTEIN have not reinvented the wheel, but we have reinvented the gear wheel. In this paper the question shall be explored how the mental path to the disruptive invention of the galaxy gear was and when and how the abilities of individualists affected teams the successful search in the space of possibility by the simultaneous use of specialized knowledge creativity and the use of the abstract TRIZ method decisively.

Keywords: *knowledge, creativity, abstraction, TRIZ, conscious and unconscious spheres of thinking, new category*

1 Project

1.1 The WITTENSTEIN SE:

With around 2,600 employees worldwide and sales of €385 million in fiscal 2017/18, WITTENSTEIN SE stands for innovation, precision and excellence in the world of mechatronic drive technology both nationally and internationally.

The Group comprises six innovative business segments, each with its own subsidiaries: servo gear units, servo drive systems, medical technology, miniature servo units, innovative gear technology, rotary and linear actuator systems, nanotechnology as well as electronic and software components for drive technology.

1.2 Problem definition

Gears are required for many manufacturing steps in production plants. Due to their extremely wide distribution, advances in gear technology have a direct impact on production costs worldwide and on the overall energy consumption of modern civilisation.

Gears and their specific properties are therefore of great economic and environmental relevance.

However, all previous types of gears have one problem in common: The high surface pressures between the teeth due to the point or line contact and the low number of supporting teeth in involute/cycloid gears limit the performance capability of the gears. Or to put it more simply: If two gears mesh, the force between the gears is only transmitted at one point of a few teeth, the others "go on holiday", so to speak. And precisely for this reason, the productivity of the machines, robots and systems in which drives are used, which are used all over the world, has so far been limited.

1.3 State of the art

Gearboxes have been around for a long time.

Already Leonardo Da Vinci described the types of gears in the 15th century. Leonhard Euler then developed the mathematically ideal tooth form the involute in the 17th century. James Watt used the now widely used planetary gear for the first time industrially in his steam engine.

Since then, much has been optimized and varied, but nothing fundamentally new has been developed. We at WITTENSTEIN have asked ourselves this question:

"What does the next generation gearbox look like that should be better than the state of the art in all respects by a factor of one factor or another?"

In the end we did not reinvent the wheel, but at least we reinvented a cogwheel, and from it, a radically new genre, the galaxy drive, which enables productivity leaps in mechanical engineering.

1.4 Inventive solved task

The new type of gear, with a toothing that offers surface contact and an extremely large number of load-bearing teeth, enables a quantum leap not only in terms of precision, compactness and material requirements, but also significant savings in energy consumption.

With the "inventor method" TRIZ (a systematic approach for disruptive innovations) it was possible to work out the basic conflicts of today's gear drives and to develop four generic innovation principles to solve these basic problems.

The result was the invention of a completely new type of gear - now scientifically proven - with which it was possible to break the typus that had been used in mechanical engineering for centuries and invent a new type of gear. In spite of the otherwise generally valid knowledge that "one should not reinvent the wheel", a new (toothed) wheel was developed which can do more than the state of the art by factors.

The invention process

Developing and communicating visions of the future from paradoxes

At the beginning of a great invention there is often a paradox or an oxymoron.

A paradox is a statement that seems to contain an irreconcilable contradiction. An oxymoron is a rhetorical figure in which a formulation is formed from two opposing, contradictory or mutually exclusive terms. The best-known example is the "black mould".

In our case, it was a corporate paradox:

"The drive should be there, but not take up any space".

From this, two company oxymorons developed over time.

In all seriousness, the owner of the company demanded that we finally develop an air motor and an air gear. The demand met however predominantly with incomprehension and was largely ignored. I took up this thought and developed a second somewhat more concrete Oxymoron the "Motriebe" the Fusion of engine and transmission.

To develop such thoughts is very important. However, these are of no use if they only find resonance in the minds of very few. According to the motto "Innovation through provocation", the visionary vision developed must be presented to a broader group within the company. I did this in an internal developer conference in which all the engine, gearbox and system developers at WITTENSTEIN SE were together. Based on the development direction of recent years, I used an animated Power Point presentation to show what our goal for the next few years could or should look like.

The subsequent discussion was dominated by statements such as:

- Power Point is patient
- One may certainly "spin" but one should not exaggerate this into the grotesque.
- Mr. Bayer, are you aware that the laws of physics also apply to you?
- etc...

When we see this act in the light of Platonic Ideas, at this moment a new thought arose, recognizable by many, in the space of previously unthought possibilities. The participants felt this intuitively. Therefore there was a lack of understanding, confusion and rejection, but no totally devastating criticism in the space of events. Some felt the collapse of an established and beloved logic of thought and that something not yet imaginable could, should, should come now.

Developing ideas by overcoming mental boundaries

The product vision was now created and existent. Now these still distant thoughts had to be transferred into the "me in the now".

With the help of creativity techniques, we tried to detach ourselves from the state of the art in order to find new approaches. This was done by a small team of 2-3 employees.

However, the results were always only sub-variants of known concepts.

At this point frustration spread.

Probably there are only the known concepts. If hundreds of thousands of inventors have come up with nothing better in the last 500 years, why should we come up with something fundamentally different after such a long time in the small village of Igersheim? Everyone was sobered and mentally burned out. Do another brainstorming round? - please don't. What is the point of that we have already thought through everything imaginable for us. So in this situation it would have been more than logical to cancel the project.

We - paused only two weeks.

Afterwards I asked the team to try a new, different approach. Apparently the lateral jump in the possibility room wasn't big enough. Mentally, we were still too close to the usual way of thinking in the industry. Who helps us to make a bigger leap in the possibility space? We felt very lonely and helpless and our head was empty.

Instinctively I feel in this situation that there could or should be something else after all? For many years I have been working with the

- Method of inventive problem solving - TRIZ for short.

Although this method is very abstract and complex, it made sense to use it. Because in this situation we were ready for completely new things.

So I suggested to dare a new beginning with TRIZ and motivated the team to venture into the loneliness of the mostly empty space.

2 TRIZ relation

TRIZ is the only method that not only offers a methodical approach, but also provides the solution knowledge of hundreds of thousands of successful problem solutions in an abstract way. It makes use of the systematic analysis of patents which is accessible to the user with the help of an opposition matrix.

The question to the inventive world knowledge is: was or is there anyone who was also in a field of conflict identified by us? And if so, which of the forty possible innovative solution strategies did he use to solve the problem? The contradiction matrix, which is based on the analysis of hundreds of thousands of successful problem solutions, gave us the first answers.

Protect our favorites:

IP 1: Principle of decomposition or segmentation , IP 12: Principle of equipotential
IP 15: principle of dynamisation, IP 3: principle of local quality

Especially the IP 12: Principle of Equipotential (The working conditions have to be changed so that the object can work with constant energy potential, e.g. does not have to be lifted or lowered) caused a lot of incomprehension and confusion in me. What should a gear or a gear wheel look like that has a good equipotential? Nothing meaningful to me!

We came again to the frustrating point, that we admitted to ourselves, that our methods, which we applied, already led us out of our thinking templates.

But into lonely areas in which we did not recognize any attractive solutions. What to do. Give up or better, take another "creative break"?

I had no idea and no plan how it could go on, but one thing I felt intuitively very strongly. Apparently there is no better revolutionary concept how to build gearboxes. But so it is, expect again, but there should be a solution then it must have something to do with segmentation, equipotential, dynamization and local quality.

These terms developed to extremely strong mental stimulus words, which pursued me for weeks at day and night. Were they meaningful and goal-oriented or did they just lead me into a spiritual wasteland?

to transfer abstract thoughts into reality

Especially at night this new kind of confused brain food fired my grey cells. Every morning I had new real pictures in front of my eyes which I discussed with my colleagues during the day and combined with their thoughts.

We "fertilized" each other with these strange thoughts and had more and more the feeling that there should be something.

But now to the inventive reality. We looked intensively at the

IP 12: Principle of equipotential.

"The working conditions must be changed in such a way that the object can work with constant energy potential, e.g. it does not have to be lifted or lowered.

What does this mean for a gearbox? In a planetary gear, the planet wheels move up and down on a circular path around the sun wheel. The movement of the cycloidal eccentric gear is similar. Next attempt. What does equipotential mean for a gear wheel?

Let's take a look at a planetary gear. Only 10% of the time the teeth do something. 90% of the time you go on holiday.

To make things worse, all the teeth on the gears, however they are designed, have a bad equipotential.

But how do you make a gear with good equipotential and good work ethic?

How do you get the teeth to almost always be in mesh and only move minimally up and down?

How can we keep the described positive characteristics but still achieve a rotary motion with the highest possible transmission ratio?

So let's take the Innovative Principle IP1 as a parallel measure.

IP 1: Principle of disassembly or segmentation

What does this mean for our gear wheel?

What does a gearwheel consist of? Answer: of teeth and a tooth body. But only the teeth really do the work. So the ideal is to have single (segmented) teeth that almost always do their work in a fraction of a second and that keep our equipotential requirement.

But then still nothing moves and the stiffness of a gear wheel is also lost. The next innovative principle helped us here.

IP 15: principle of dynamisation, IP 3: principle of local quality

Especially the IP 12: Principle of Equipotential (The working conditions have to be changed so that the object can work with constant energy potential, e.g. does not have to be lifted or lowered) caused a lot of incomprehension and confusion in me. What should a gear or a gear wheel look like that has a good equipotential? Nothing meaningful to me!

We came again to the frustrating point, that we admitted to ourselves, that our methods, which we applied, already led us out of our thinking templates.

But into lonely areas in which we did not recognize any attractive solutions.

What to do. Give up or better, take another "creative break"?

I had no idea and no plan how it could go on, but one thing I felt intuitively very strongly. Apparently there is no better revolutionary concept how to build gearboxes. But so it is, expect

again, but there should be a solution then it must have something to do with segmentation, equipotential, dynamization and local quality.

These terms developed to extremely strong mental stimulus words, which pursued me for weeks at day and night. Were they meaningful and goal-oriented or did they just lead me into a spiritual wasteland?

To transfer abstract thoughts into reality

Especially at night this new kind of confused brain food fired my grey cells. Every morning I had new real pictures in front of my eyes which I discussed with my colleagues during the day and combined with their thoughts.

We "fertilized" each other with these strange thoughts and had more and more the feeling that there should be something. But now to the inventive reality. We looked intensively at the

IP 12: Principle of equipotential.

"The working conditions must be changed in such a way that the object can work with constant energy potential, e.g. it does not have to be lifted or lowered.

What does this mean for a gearbox? In a planetary gear, the planet wheels move up and down on a circular path around the sun wheel. The movement of the cycloidal eccentric gear is similar. Next attempt. What does equipotential mean for a gear wheel?

Let's take a look at a planetary gear. Only 10% of the time the teeth do something. 90% of the time you go on holiday. To make things worse, all the teeth on the gears, however they are designed, have a bad equipotential. But how do you make a gear with good equipotential and good work ethic? How do you get the teeth to almost always be in mesh and only move minimally up and down? How can we keep the described positive characteristics but still achieve a rotary motion with the highest possible transmission ratio?

So let's take the Innovative Principle IP1 as a parallel measure.

IP 1: Principle of disassembly or segmentation

What does this mean for our gear wheel?

What does a gearwheel consist of? Answer: of teeth and a tooth body. But only the teeth really do the work. So the ideal is to have single (segmented) teeth that almost always do their work in a fraction of a second and that keep our equipotential requirement. But then still nothing moves and the stiffness of a gear wheel is also lost. The next innovative principle helped us here.

IP 15: Principle of dynamisation

The segmented equipotential of optimally guided single teeth could be dynamized if necessary. But how do you do this?

The idea now arose to guide the individual teeth in a tooth carrier and then somehow move them back and forth a little dynamically. In this thought model it was now possible that almost all individual teeth were in use, only if the tooth was from one to the next tooth gap of the hollow wheel changed was he in the millisecond range nothing. But from 10% use to 90% vacation in the state of the art 98% use and 2% vacation were now possible. This showed that we were on the right track.

IP 3: Principle of local quality

In the state of the art, all gears have a point or line contact which deforms into a pressure ellipse due to the elasticity of the material.

Only in this area can force be transmitted in the form of surface pressure. Now we again forced ourselves to think in terms of the extreme ideal. Instead of the pressure ellipse moving along the tooth flank, it would be optimal if the complete tooth flank were available for force transmission. So a tooth flank with surface contact.

However, this could not roll more.

We were one step further again.

The ideal gear thus has individual teeth that are almost always in use and whose flanks are shaped in such a way that they provide the complete surface for hydrodynamic power transmission. Rolling gears are apparently not the optimum solution after all. The next big hurdle appeared before us and had to be overcome.

The question was: which internal gear kinematics are capable of fulfilling the previously described requirements and at the same time enabling mathematically exact synchronism? The involute, discovered by Leonhard Euler in 1760, in which one rolls straight on a circle, was considered to be the most widespread optimal tooth shape to date.

A new basic function had to be created or discovered in the direction of the IP3 local quality.

We didn't want to roll over like everyone else. Instead, we wanted to move a single tooth as linearly as possible in a guide outwards into the ring gear. The problem was that this tooth had to move continuously and at the same time a real surface contact between the newly invented tooth flank and the ring gear flank was made possible. The youngest but most mathematically talented member of the team brought the logarithmic spiral more and more into the discussion.

In the time when this also began to work with me I saw it on a Sunday evening at my PC and typed at Google pictures "logarithmic spiral" spiral.

There appeared beside the graphics of the Fibonacci golden and the pure logarithmic spiral photos of snail shells, whirlwinds, sunflowers, and whole spiral galaxies.

It seems that nature has been using the logarithmic spiral for billions of years as an ideal function for force and power transmission as well as for geometric optimal arrangements.

The snail shells are constructed according to the logarithmic spiral in order to achieve maximum stability and robustness against external forces with as little material input as possible. In the logarithmically shaped arms of hurricanes, as we know them from satellite images of the Caribbean and tropical hurricanes. Huge achievements are brought "to the point". But also the hundreds of billions of stars in spiral galaxies are arranged according to the logarithmic spiral. Be it in space or on earth. Everywhere the logarithmic spiral has proven to be ideal.

When I realized this "it was cold running over my back".

Apparently we were on the trail of something big. Because if this function had turned out to be an ideal in nature, then it would also have to be an optimum for gearbox construction!

The technology of the galaxy transmission

Parallel to the semantic development we made ourselves countless sketches.

In which we progressed our thoughts to visualize.

At the end we had the overall concept shown in figure 1.

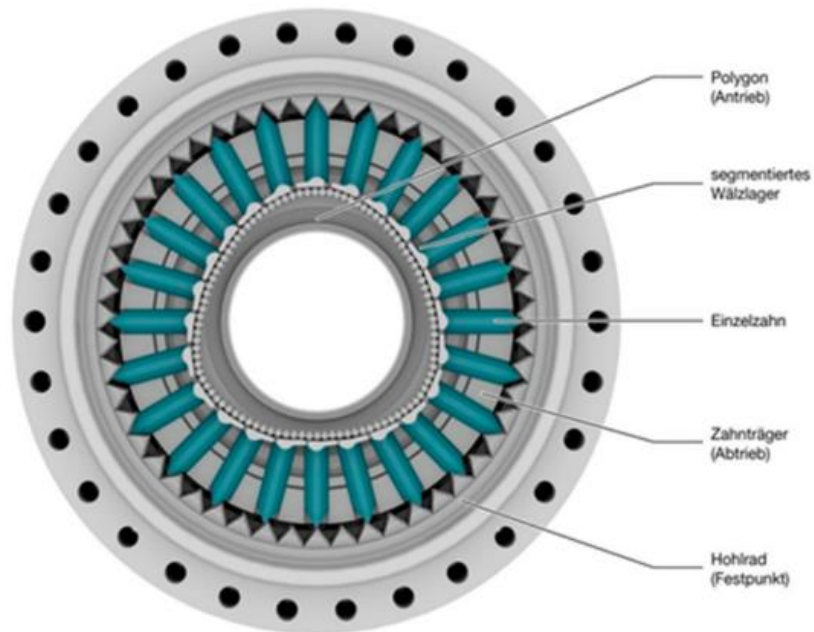


Fig 1 The Galaxie Gear

Results

The technical improvements of the Galaxie® drive system in relation to the market standard of a comparable size:

- Maximum torque increased by 70 to 170 %.
- Emergency stop torque increased by 150 to 300 %:
- Torsional stiffness 340 to 580 % higher
- Efficiency 18 to 29 % higher
- Hollow shaft 3 to 70 % larger
- Zero play and practically wear-free
- best positioning accuracy with excellent synchronism
- Weight reduction due to (up to two) size reduction

Mechatronic drive systems such as the Galaxie® are used in automated production machines of all kinds. Whether food, packaging, medical equipment, vehicles, wind turbines, robots or machine tools - almost all everyday goods are produced with the aid of motor-gear units or use such drive systems.

Thanks to its new concept, the Galaxie® transmission achieves an enormous increase in all performance features by several hundred percentage points. At the same time, the innovation reduces the use of materials, consumes fewer resources and protects the environment. Engineers and designers can completely rethink their machine concepts and realize real development leaps, as several practical examples have already shown: In the case of lathes, work processes were considerably shortened and the tools showed much less signs of wear. In gear hobbing, undesirable vibrations were reduced to a minimum and the machining time was significantly shortened. A newly developed five-axis milling machine was able to increase the cutting performance by 100 %. WITTENSTEIN sees enormous potential in the medium to long term for previously untapped markets, industry 4.0 and new materials.

3 Conclusions

In 2015, WITTENSTEIN presented a radical innovation in the gear unit sector after centuries of only optimising and varying it.

If you look at the outstanding performance data (see 3), you can see clearly, that this is THE innovation in the transmission sector.

Not least for this reason, the Galaxie® gearbox has now been recognized as a "milestone in drive technology" in science and industry. In the book "50 Jahre FVA: sharing, drives, innovation" (Link:http://fvanet.de/fileadmin/download/50_Jahre_FVA__sharing__drive__innovation/) published in autumn 2017, the German Drive Technology Research Association calls the Galaxie® drive system "a joint achievement in a long series of important inventions of modern times, such as those by Leonardo da Vinci, August Otto, Friedrich Fischer and Rudolf Diesel.

We at WITTENSTEIN have not reinvented the wheel, but we have reinvented the gear wheel. This was achieved through the combination of passionate creativity, a great deal of specialist knowledge and the methodical abstraction of TRIZ. We have thus developed a new type of gearbox - the Galaxie Getriebe®.

It is up to 580% better than the state of the art and makes it possible to build machines with unprecedented precision and productivity.

Awards:

2015: Hermes Award der Deutschen Messe auf der Hannover Messe Industrie 2015

2016: Innovationspreis der deutschen Wirtschaft

2018: Deutscher Zukunftspreis – Preis des Bundespräsidenten für Technik und Innovation
Aufgenommen in den Kreis der Besten 2018

References

1. Brecher, C., & Weck, M. (Neuaufgabe 2018 in Bearbeitung). Werkzeugmaschinenband 3. Berlin Heidelberg
2. Burger, T., Schreiber, H., & Wimmer, T. (2015). High Torque, Torsional Stiff and Precise – The WITTENSTEIN Galaxy®-Kinematics. International Conference on Gears, ICG. München

Schreiber, H. (2015). Revolutionäres Getriebeprinzip durch Neuinterpretation von Maschinenelementen – Die WITTENSTEIN Galaxie®-Kinematik. Dresdner Maschinenelemente Kolloquium, DMK. Dresden.

3. Schreiber, H., & Röthlingshöfer, T. (2017). Kinematic classification of a gearbox comprising separate thrust teeth and its advantages regarding existing approaches. International Conference on gears, ICG. München
4. Schreiber, H., Wimmer, T., Michel, F., & Schlecht, B. (2015). Die WITTENSTEIN Galaxie®-Kinematik – Exzenter-Getriebe neu gedacht. Antriebstechnisches Kolloquium, ATK. Aachen.
5. Bayer, T. Der Galaxieantrieb: Disruptive Innovation in der Erfolgsbranche Maschinenbau, DTIM Kongress "disruptive technologies and innovation foresight minds" Februar 2016, Berlin
6. Bayer, T. Disruptive Innovationen realisieren - ein Praxisbericht am Beispiel des Galaxiegetriebes
12. Aalener Kolloquium - antriebstechnische Anwendungen, März 2016
10. Aachener Technologie- und Innovationsmanagement Tagung, September 2016
7. Bayer, T. Erfindungsprozess und Technologie einer radikalen Innovation Ein Praxisbericht am Beispiel des Galaxieantriebs der WITTENSTEIN SE Innovationskongress, November 2017, Villingen

Internet:

www.wittenstein-galaxie.de

<https://www.youtube.com/watch?v=orKa0EYgics>

<https://www.youtube.com/watch?v=TK1NI2qe-zM>

<https://www.youtube.com/watch?v=DoIc7SqjnGc>

<https://www.youtube.com/watch?v=Ey7LNui1Xfw>

<https://www.deutscher-zukunftspreis.de/de>

www.deutscher-zukunftspreis.de/mediathek

<https://www.deutscher-zukunftspreis.de/de/nominierte/2018/team-1>

Youtube / Search Engines : Thomas Bayer, TRIZ, Wittenstein, Galaxie

Excerpt from publications in the technical press:

- FVA: [sharing drive innovation](#)
(Link: http://fva-net.de/fileadmin/download/50_Jahre_FVA_sharing_drive_innovation/) 2017; S.98-99. Auf zu neuen Galaxien
- Produktion Technik und Wirtschaft für die deutsche Industrie; 3/2015; Nr. 12; S.4-5. Zähne zeigen. Von der Idee zum neuen Getriebe – ein Erfinder erzählt.
- VDI-Nachrichten; 27.3.2015. Zahnstifte revolutionieren Getriebe. Martin Ciupek.
- MM Maschinenmarkt; 18/2015. Logarithmische Spirale statt Evolvente. Stefanie Michel.

Excerpt from publications in the press:

- Bundeswirtschaftsministerium; 13.4.2017. Hermes Award 2015 für einen neuen Antrieb der WITTENSTEIN AG
- Welt.de; 12.4.2015. Antriebsspezialist Wittenstein erhält Hermes Award für Getriebeteil

- Südkurier; 12.4.2015. Antriebsspezialist Wittenstein erhält Hermes Award für Getriebeteil
- Finanznachrichten.de; 13.4.2015. Wittenstein AG wird mit dem Hermes Award 2015 ausgezeichnet.
- Rhein-Main-Zeitung; 18.04.2016. Neue Ideen für den digitalen Wandel / Verleihung des Innovationspreises der Deutschen Wirtschaft
- Deisternd Weserzeitung; 18.9.2018. Zahnrad neu erfunden
- Stuttgarter Zeitung; 13.9.2018. Neues Getriebe entwickelt
- Neue Presse, 13.9.2018. Das Superzahnrad bringt die doppelte Leistung
- Stuttgarter Zeitung; 13.9.2018. Endspurt der Tüftler
- Produktion; 14.11.2018. Das Getriebe-Prinzip auf den Kopf gestellt.
- Fränkische Nachrichten/Mannheimer Morgen; 6.12.2018. Neue Getriebegattung erregt Aufsehen
- antriebstechnik; 1-2/2019. Mit Getriebegattung im „Kreis der Besten“

Communication

Communicating Author: thomas.bayer@wittenstein.de

TRIZfest 2019

September 11-14, 2019. Heilbronn, Germany

ALGORITHM OF ENHANCED FUNCTION-ORIENTED SEARCH

Stéphane Savelli^a, Oleg Feyngenson^b

^a*MP Solving, Brussels, 1180, Belgium*

^b*Samsung Electronics, Suwon, 443-742, South Korea*

Paper Classification:

- TRIZ-related methods and tools development

Abstract

Function-Oriented Search (FOS) is a powerful problem solving tool of the modern TRIZ. However it has still some areas for improvement, including the following ones: the identification of Function-Leading Areas depends partly on the TRIZ practitioner's knowledge and the efficiency and quality of searches within Internet browsers is not guaranteed. The main objective of the current research is to increase the probability of identifying non-obvious solutions from different remote areas of science and engineering. In this paper, an Algorithm of Enhanced FOS is proposed. This algorithm includes new steps developed based on practical experience of the authors as well as on the learnings from some selected academic examples.

Keywords: *Function-Oriented Search (FOS), algorithm, Enhanced FOS, Function-Leading Area, search pattern.*

1 Introduction

In their seminal paper of 1956 [1], G.S. Altshuller and R.B. Shapiro suggest different approaches for the “elimination of the cause of a technical contradiction”. One of these suggested approaches is the search for “typical solutions”, i.e. for direct analogies in Nature and in other areas of technology (with regards to the initial area of innovation). In these pieces of sentences, the today TRIZ practitioner immediately recognizes the embryos of two TRIZ tools based on functional analogues, namely the Scientific Database Application (SDA) [2] and Function-Oriented Search (FOS) [3] [4] [5] [6]. Actually, the present paper focuses on FOS; despite its interest, its object is not to discuss SDA or the possible interplay between SDA and FOS.

In practice, FOS is used either at the analytical stage (of an innovation roadmap) under its specific form known as Benchmarking of Technologies [7], or at the solving stage for the solving of key problems. In the latter case, key problems are expressed in a functional way of the following, generic form: how to [functional verb] [function recipient]? For example, how to remove Martian dust (from a solar panel)? [8]

According to the authors, the two most important steps of the FOS algorithm are the function generalization and the identification of function-leading areas (FLA). Those areas are areas of science and engineering which have developed technologies which fulfil the same generalized function with different functioning principles or with the same functioning principle, in a more efficient way, as compared to the initial innovation area, because performing this function adequately and reliably is more important or because the same function should be performed in more challenging conditions [7]. Once FLA have been identified, it is easier to identify the technologies developed within these FLA. However, the FLA identification still partly relies on the personal knowledge and experience of the TRIZ practitioner. Fortunately, this limitation can be partially overcome in the following ways:

- To look directly in some specific areas of the industry well known for having invested lots of resources in the development of specific technologies (biomedical, aerospace, nuclear, military and toys [7]).
- To look directly into inanimate and animate Nature [7], the latter “having developed” a huge bunch of biological solutions over several billions of years, which might be worth mimicking or using directly (as suggested in [1]).
- To broaden the search perimeter by considering in addition to the generalized function, the result of the function [7] and the impression of the result of the function [9].
- To perform a direct search for alternative technologies and their functioning principles in current, generic Internet browsers like Google and possibly in specific (patent, scientific, technical) databases [10] [11]: this approach is usual for the TRIZ practitioner which then often skips the 7th step of the FOS algorithm [5] related to the FLA identification (note that it is the same when practicing SDA). This is made possible because these browsers index the majority of specialized books, magazines, journal articles, patents and patent applications. However the quality and the exhaustive character of the search are still not guaranteed because they strongly depends on the search request whose definition is left to the subjective appreciation of the TRIZ practitioner and can therefore be unobvious.

Noteworthy the use of a specific artificial intelligence whose requests are expressed functionally [12] could theoretically help overcome this limitation; however, despite its high potential, this development still needs to mature and be commercially available to be used by TRIZ practitioners and properly evaluated. Last, a FLA database could also be helpful [13]; however this systematic, huge project has not still been initiated by the TRIZ community.

Consequently, the FOS algorithm could readily be refined through the integration of the 4 above recommendations. Nevertheless, the two aforementioned disadvantages of the current FOS algorithm (the FLA identification is still partly dependent on the TRIZ practitioner knowledge and the efficiency and quality of searches on Internet browsers is not guaranteed to be optimized) still exist and there is a need to address them further.

2 Challenging the notion of Function-Leading Area

While performing FOS by searching within Internet browsers and specific databases, and possibly by asking an expert, one finds technologies from different areas of science and industry.

From a pure logical point of view, these technologies belong either to FLA or to FnLa (Function-non-Leading Areas). FnLA are areas where performing the generalized function adequately and reliably is less critical than in the initial innovation area, or where the same function should be performed in less challenging conditions. Does it mean that these FnLA and their corresponding technologies should therefore be systematically discarded while applying the FOS algorithm?

This legitimate question can be answered through an example taken from a project executed in 2014 for a client. The engineering system of interest was the anemometer which measures the aircraft speed relative to the external air. Actually, it gives as output a calculated calibrated air speed (CAS). It comprises 3 pairs of identical systems having different locations at the front of the fuselage. Each system comprises a Pitot tube (dynamic sensor which measures the pressure exerted by the air flow i.e. the total pressure) and a static port (which measures the external air pressure i.e. the static pressure) which is flush to the fuselage.

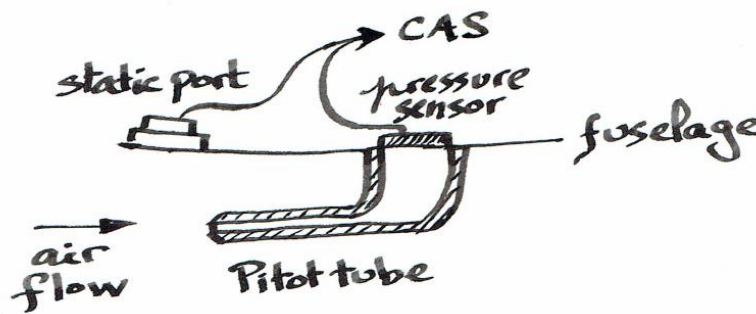


Figure 1: Schematic aircraft anemometer comprising a Pitot tube and a static port

In some very rare conditions, either ice crystals (see Fig. 2) or supercooled water droplets quickly build ice inside and possibly onto the 3 Pitot tubes at the same time, despite the Pitot tube active anti-icing system. As a result, the 3 air speed measurements are false: this is the so-called common point failure. Consequently the anemometer gives to the aircraft systems a false CAS, which in turn can lead to catastrophic consequences, as illustrated by the analysis of the Air France Flight 447 crash in the Atlantic Ocean in 2009 [14].

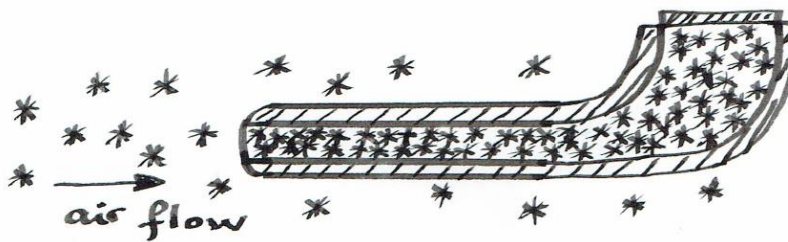


Figure 2: Schematic cut section view of a Pitot tube clogged by ice crystals

The objective of the so-called Airflow project was to generate anemometry innovative conceptual solutions which substantially reduce or eliminate the risk of a false aircraft/air speed measurement due to Pitot tube icing. The project’s scope was focused on the air speed measurement (not on signal treatment and analysis, and not on ice detection), and both improvements of the current system and radically innovative solutions were in the scope. In the Benchmarking of Technologies, the anemometer main useful function was generalized into “measures speed of a fluid”. Actually this formulation - as any such function formulation for a measurement - doesn’t

comply with the requirements of a function in modern TRIZ because the goal of the measurement is not to modify or maintain a parameter of the fluid (despite the fact that any measurement system will expectedly modify one or several parameters of the fluid, but that is not its purpose). However it turns out to be very practical and remarkably it is already used so in SDA. In other words, if one needs to perform a search for measurement systems we need to describe this system of interest: what does it measure, under which conditions, with which accuracy, etc. On the basis of that generalized function, SDA and FOS including extensive Internet searches were applied. In addition, the use of patent categories within Espacenet (European Patent Office database) [14] was useful, despite the huge number of found patents and patent applications. As a result, in addition to the initial anemometer's technology, 12 alternative technologies having different functioning principles were selected and benchmarked according to the following criteria: probability that the ice crystals or supercooled droplets perturb the airflow measurement, compatibility with the existing aircraft requirements, easiness of maintenance procedure, level of development and cost. The respective criteria weights were 10, 10, 5, 1 and 5. The initial anemometer turned out to be the winner of the Benchmarking of Technologies: this means that it had still a substantial improvement potential. Also, the Venturi meter (which measures the differential pressure across an obstruction, which is a function of the air flow speed, see Fig. 3) followed very close behind, meaning it carried the potential for radical innovation.

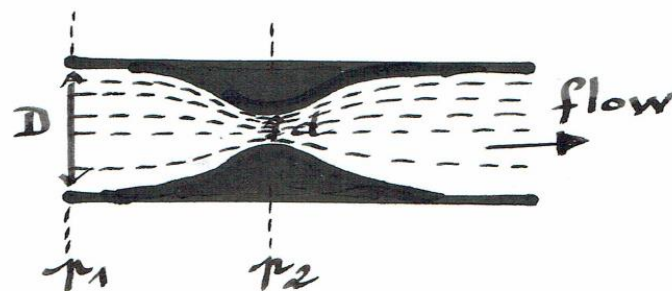


Figure 3: Schematic cut view of a Venturi meter ($d < D$ and $p_2 < p_1$)

As compared to the aircraft industry, the Venturi meter area is clearly an FnLA (Function non-Leading Area) for its function is not performed more efficiently inside its industry (air conditioning) than the function of the anemometer in the aircraft industry; also it functions in less critical conditions (lower air speed, no atmospheric precipitation). However, as compared to the Pitot tube, the Venturi technology turns out to possess one specific feature which might be useful for the Airflow project: its open and crossing character. Indeed this feature makes the Venturi less susceptible to ice clogging, and potentially easier to unclog thanks to the crossing airflow, as compared to the Pitot tube, inside which air is immobile. The further analysis of the Venturi allowed defining one key problem (among 20+ other key problems): how to expel ice from the Venturi (external and internal) surfaces? At the solving stage, FOS was applied again so as to solve this key problem. Among 10 selected technologies, the pulse electro-thermal de-icing [15] (PETD) was selected for the Venturi. This technology works also in evaporating mode (PEED). Actually, the material at its surface is electro-conductive and has tiny capillaries, and as soon as strong electric current pulses are fed within the Venturi, the ice melts almost immediately and the remaining ice is expelled by the pressure of ice vaporized in the capillaries. Noteworthy this technology turns out to have been recently (at the time scale of the aircraft industry) developed for de-icing / anti-icing aircraft leading edges. In other words, PETD was found in the initial innovation area.

Still the location of the holes on the Venturi is not ideal: they might still be clogged or partly clogged under severe icing conditions, more easily than a static port. Thus another key problem had still to be solved: how to modify the holes so that the hole clogging risk is eliminated? The hole at the obstruction was displaced behind the obstruction, taking advantage that the ice crystals or super-cooled ice droplets have an important mass inertia as compared to the air and therefore fly straight away. Furthermore, the front hole was eliminated and substituted by a static probe, less susceptible to icing (see Fig. 4) thanks to its flushness to the fuselage. Finally, this conceptual solution (among 20+ that were proposed) works as follows: as soon as the icing of the Venturi meter is detected in some way (still to be determined), the PETD sub-system is switched on, and the ice which is expelled from the internal surface is pulled away by the air flowing across the Venturi. At the evaluation stage, this conceptual solution was evaluated as the best innovative solution for mid-term, while an innovatively improved Pitot tube was evaluated as best solution for short-term.

Thus the former example taken from the Airflow project suggests two additions to the FOS algorithm:

- To seek for technologies in the whole technosphere, not limiting the search to FLA, for FnLA may bring technologies with specific features fitting very well the specific need of a specific innovation project.
- To seek for technologies in the same area, because some systems close to the initial system may experience the same issues as the system at hand.

Last, if FOS applies to a measurement, using the modern TRIZ formulation of a measurement function “to inform a person / a system” will be too general to look for innovative or more efficient technologies. Thus in that case it is recommended to use the "incorrect", generic function formulation: "to measure the parameter x of component y".

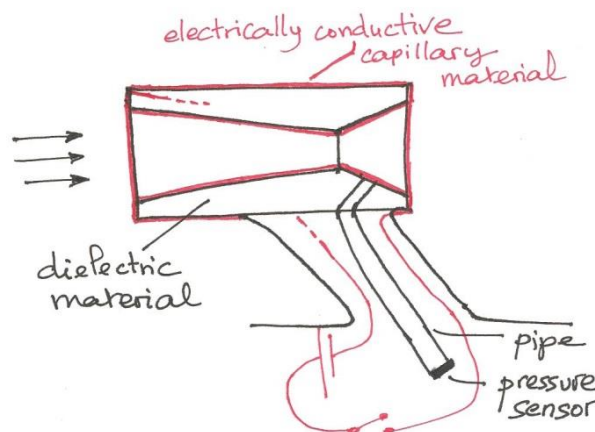


Figure 4: Venturi flowmeter with pressure sensing hole behind the obstruction, with pulse electro-thermal de-icing (PETD) technology applied on its external and internal surfaces

3 Enhancing search patterns

In its 6th step of function generalization, the FOS algorithm suggests a powerful search pattern. This search pattern can be enhanced in some particular cases, as illustrated in the two next sub-chapters. Also, especially in the context of an automatic search, this search pattern

can be enhanced if one investigates thoroughly the generalized function, as shown in the 3rd sub-chapter.

3.1 Double functions

Let us consider an example. A usual ice cube tray is filled with water and put in the freezer. Ice begins its solidification from the top, and from pure water. During solidification water dissolved gases are rejected in the remaining water, producing gas bubbles that are finally trapped into the ice cube and give it a “milky” aspect. A Japanese company has developed and patented in 1994 an ice cube tray that produces transparent ice cubes [16]. The walls of the ice tray are insulating, ensuring a directional, vertical solidification of ice. A second compartment underneath the first one allows the gas bubbles to accumulate. As a result, the second compartment concentrates the milky aspect while the first compartment produces a transparent ice cube.

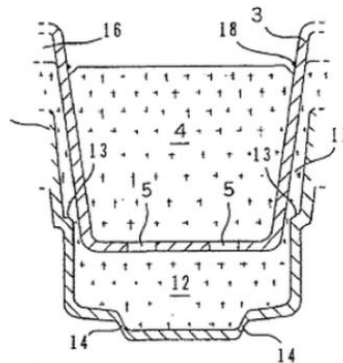


Figure 5: Double compartment single ice cube tray producing transparent ice cubes [16]

It is wished to simplify the former single ice cube tray design. Functionally speaking, the bottom of the first compartment directs water and directs gas (contained in water), while the second compartment stops water and stops gas (contained in water). It is proposed to trim the second compartment. It allows defining a trimming problem “How can the bottom of the first compartment stop water and direct gas?” FOS is applied. The generalized function is double: to direct gas and to stop liquid. An FLA for this generalized double function is the area of breathable, waterproof clothes. Actually Gore-Tex® is such a technology that performs reliably both functions: it stops rainwater and it lets the body moisture go out of the cloth as a vapor. In a later, American patent, a part of the bottom of the ice cube tray is made of a material which is waterproof and gas permeable [17].

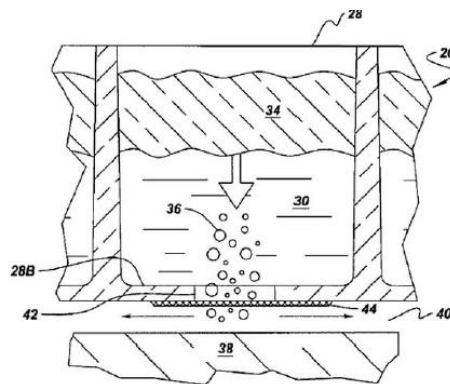


Figure 6: Ice cube tray with a bottom which is waterproof and gas permeable for the production of transparent ice cubes [17]

Thus sometimes it might be useful to apply FOS on double functions. Nevertheless in practice it can be useful to consider in parallel two key problems dealing each with one function, and apply FOS on each key problem. In the latter case, the two key problems would then be “How to direct gas?” and “How to stop water?”

3.2 *Opposite required parameters*

Let us imagine we are looking for a device for the reduction of the energy of a proton beam. This could be useful for cancer proton-therapy, for instance. Let us apply FOS. The device should fulfil the function “to reduce the proton beam energy”. The generalized function is “to reduce the energy of particles / light”. At the 5th step of the FOS algorithm, one considers the required parameters/conditions: constant energy in input, variable energy in output and fine control of the energy attenuation. It might be interesting to consider in parallel for the two first required parameters: variable energy in input, constant energy in output; these are opposite required parameters. Actually one finds a technology used successfully for maintaining constant the output energy of a synchrotron X photons decaying beam with 100 μm diameter [18]. It is based on two triangular pieces of silicon and fused silica cut with a wafer saw. The photon energy can be monitored continuously and is uniform across the beam diameter. This conceptual solution might be suitable for the proton attenuator. It might be necessary to adapt it, e.g. to seek for another material suitable for protons.



Figure 7: Dynamic X-ray beam attenuator used for maintaining constant the output photon energy while the input energy is decaying [18]

So in some instances of the FOS application, it might be useful to consider for some required parameters their opposites.

3.3 *Systematically investigating the generalized function*

The most critical stage of FOS is believed to be the identification of FLA. For that identification, one considers the generalized function, i.e. a generalized function verb and a generalized object. This search pattern is exhaustive: *a priori* it allows looking for all possible FLA within the whole technosphere. However its efficiency is limited. So as to increase the search pattern efficiency several approaches are proposed below.

Specifying back the generalized function and its generalized object

In a movement which is opposite to the function generalization, it is suggested to list the alternative specific functions and objects. As an example, let us consider again to the generalized function “attenuate the energy of particles / light”. In this case, the possible specific objects of the function are numerous: protons, neutrons, electrons, photons, atoms, ions, and all possible sub-atomic particles (these are called back specified function recipients). Also the possible specific functions might be: absorb, deflect, reflect, diffract and diffuse (these are called back specified functions). It might be useful to specify further the function according to the nature of the object, and the objects themselves. As an example, photons might be visible light, UV, infrared,

X-ray, gamma rays, radio waves, microwaves and so on. Beyond the wavelength, other parameters of light might be considered, e.g. polarization. The different combinations of the remaining, specific functions and specific objects should be considered systematically. Some combinations might be irrelevant and should then be discarded. This back specification of the generalized function allows a better identification of FLA because the search patterns are more specified and more numerous. Considering a search performed by an engine, technologies might be identified at the same time as FLA.

Looking for backward or forward components along the function model

Let us continue with the former example, that of X-rays. In this case, the following questions arise:

- How to generate X-rays? How to detect X-rays?
- What are the different purposes of X-rays?

From a functional point of view, these questions point towards other components than the X-rays and the sought technologies (for the reduction of the X-rays energy) backwards and forwards with regards to the “X-rays” component in the function model. In general, we look for other components than those of the back specified function (function carrier and function recipient) in any system or super-system comprising them. This general search pattern is schematized in Figure 8.

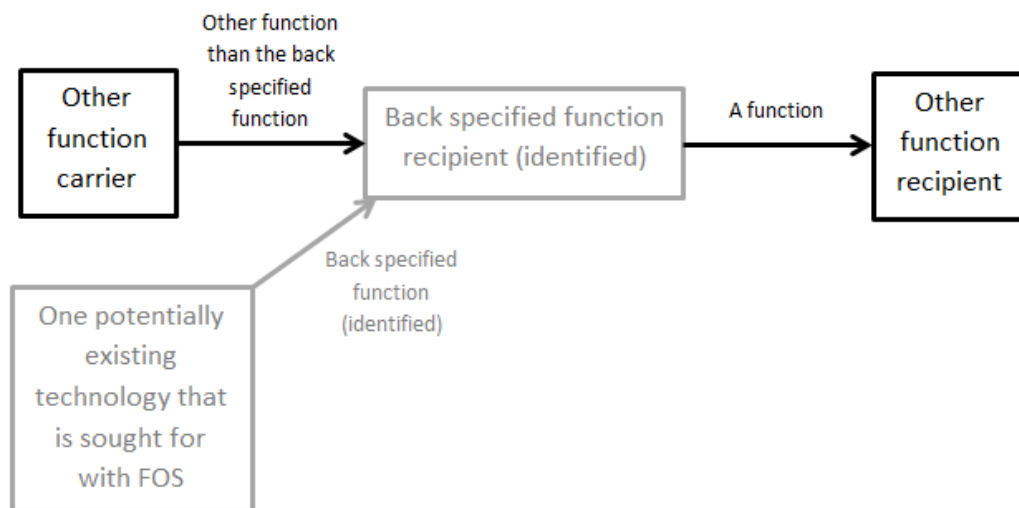


Figure 8: General search pattern for another function carrier performing another function on a back specified recipient of a back specified function; general search pattern for another function recipient on which the back specified function recipient fulfils a function (what is searched is in black)

In the X-rays example, we may find for instance:

- As other function carriers performing another function on X-rays:
 - Components or systems generating X-rays:
 - X-ray tube
 - High energy protons or ions
 - Natural or artificial lightning electrons
 - Celestial objects (in X-ray astronomy)

- Components absorbing X-rays:
 - Human and animal body parts (in radiography, tomography, radiotherapy)
 - Material samples (in radiography, tomography)
 - Luggage (scanner controls at airport)
- Components diffracting X-rays:
 - Crystalline samples (in X-ray crystallography)
- As other function recipients on which X-rays perform a function:
 - X-ray detectors
 - Human body parts (possible harmful functions: burns, cellular damage)
 - Material samples (in X-ray fluorescence, X-ray microscopy)

The former list is not closed; it is just a sample showing the proposed approach. This list shows already some areas that emerge. A thorough list of areas could be built on the basis of the former objects list. Once the list of areas is constituted, one can begin jointly investigating within these areas which ones have developed technologies for the attenuation of X-rays and what are these technologies.

Transforming search patterns into search requests

In the case the search is performed within a specific database or a general database with the help of a search engine, keywords are needed. So in practice, so as to build this double list of areas and technologies, which keywords should be used?

Here there is no strict rule to follow, and the empiric experience of the TRIZ practitioner is major. However, some recommendations can be made. Thus it is recommended to select relevant keywords combinations, where the keywords can be (along with and/or logical connectors):

- The verb of the generalized function (e.g. to attenuate).
- The name of the generalized object of the generalized function (e.g. particle or light).
- The verb of a specified function (e.g. to diffract, to reflect).
- The name of a specified object of a specific function (e.g. X-ray, electrons).
- A name related to technologies backwards the functional chain (e.g. synchrotron, airport luggage scanner) or the area of application (e.g. X-ray astronomy) (see § 3.3.2).
- A name related to technologies forwards the functional chain (e.g. detector) or the area of application (e.g. X-ray fluorescence) (see § 3.3.2).
- Nominative equivalents of functional verbs (effects / equipment, e.g. attenuation / attenuator).
- Synonyms of the former keywords (e.g. reduce, weaken) or words with their approximate meanings (e.g. modulate).
- Parameters or features of function recipient, other function carrier or other function recipient which express the requirements or the conditions (e.g. fast, active, automatic...).

Noteworthy once an area has been identified, the search can be extended or deepened with the help of additional words which are synonyms or are related in a way or another to the former keywords and which belong to the jargon (vocabulary) of the area. For instance, once the synchrotron as a source of X-ray has been identified as an area, one may use jargon keywords like: beam, flux, radiation, beamline, absorber, blocking, beam load, filter, etc.

4 Enhanced FOS algorithm

Based on the authors' observations and recommendations described above, the following Algorithm of Enhanced FOS is proposed (its newly proposed parts are *in italic characters*):

1. Identify the target MPV to be improved.
2. Identify the target Physical Parameter to be improved in order to address the MPV.
3. Identify the Key Problem to be solved in order to improve the MPV.
4. Articulate the specific function to be performed in order to solve the Key Problem. *If two specific functions shall be performed by the same component in order to solve the Key Problem, consider in parallel two Key Problems with one specific function each and one Key Problem with the specific double function. If the specific function deals with a measurement, express the function as "measures parameter x of component y".*
5. Formulate the required parameters/conditions for performing the function. *Consider the opposites of some well-chosen, required parameters.*
6. Generalize the function by an action of function and an object. *In the case of a measurement, generalize the function as "measures generalized parameter X of generalized component Y". Consider other functions achieving the same result or achieving the impression of the same result (note: all those are the initial search patterns).*
 - 7.1. *Generate additional search patterns by specifying back alternative functions and alternative function recipients.*
 - 7.2. *Generate additional search patterns by considering other functions carriers fulfilling another function onto the back specified function recipients, and also functions fulfilled by the back specified function carrier onto other function carriers, respectively backwards and forwards the back specified function within its function model.*
 - 7.3. *Transform all the search patterns into search requests by using different combinations of and different keywords expressing the generalized or specific functions and objects, technologies and areas backwards and forwards the back specified object. The wording can be varied with the help of verb / names, synonyms and approximate terms. Use parameters/conditions as keywords.*
 - 7.5. *Refine the search requests by using the jargon (vocabulary) of the found area, including for the specified function, its objects and all relevant related terms of the area.*
 - 7.6. *Identify the Function-Leading Areas (FLA). Consider also the Function-non-Leading Areas or less advanced technologies which may possess specific features which fit well the specific need of the initial innovation area.*
 - 8.1. *Identify the most effective technologies within the FLA and the FnLA that perform the same or similar function.*

8.2. Consider close technologies of the initial area of innovation, because they may have to solve the same issue as the initial technology.

8.3. Consider the biomedical, aerospace, military, nuclear and toy industries as potential FLA.

8.4. Consider both inanimate and animate Nature as a source of FLA.

9. Select the technology (FOS Derived Solution) that is most suitable to perform the desired function based on the requirements and constraints (primarily MPVs) of the initial innovation area.

10. Identify the initial level of Similarity Factor (SF) between the conditions of performing the function in the selected technology and the initial innovation area.

11. Identify and solve the Adaptation Problems required to increase SF in order to ensure effective implementation of the selected technology.

5 Conclusions

In this paper an improved algorithm of Function-Oriented Search has been proposed. It was named Algorithm of Enhanced FOS. The authors believe that this improved algorithm allows more efficient and reliable identification of the areas from where solutions may be adapted.

Since this of Algorithm of Enhanced FOS acquires additional new steps, the further extensive testing with actual problems is required in order to reveal possible disadvantages of the algorithm proposed.

Acknowledgments

We are very grateful to Bruno Stoufflet, Chief Technology Officer of Dassault Aviation for his authorization to share some selected results of the Airflow project.

References

1. G.S. Altshuller & R.B. Shapiro. The psychology of inventive creativity. *Voprosy psikhologii* [Issues of Psychology], No. 6, 1956, pp. 37-49.
2. Creax Function Database of effects. <http://www.productioninspiration.com/>
3. S. Litvin. New TRIZ-based tool – Function-Oriented Search. ETRIA Conference TRIZ Future 2004. November 2-5, 2004, Florence, Italy.
4. S. Litvin. TRIZ readings – Altshuller’s tradition continues. ETRIA Conference TRIZ Future 2005. November 16-18, 2005, Graz, Austria.
5. S. Litvin. Function-Oriented Search solutions substantiation. TRIZfest 2007, July 9-12, 2007, Moscow, Russia.
6. S. Litvin. FOS practical recommendations. TRIZ Developers Summit 2008. July 24-26, 2008, Saint-Petersburg, Russia.
7. GEN-TRIZ training materials.
8. [https://en.wikipedia.org/wiki/Opportunity_\(rover\)](https://en.wikipedia.org/wiki/Opportunity_(rover))

9. N. Bogatyrev et al. TRIZ-based algorithm for biomimetic design. World Conference : TRIZ Future 2011-2014. Procedia Engineering 131 (2015) 377-387.
10. <https://worldwide.espacenet.com/>
11. <https://www.sciencedirect.com/>
12. Creative AI as an equal partner for inventors. Valeri Tsourikov. Keynote lecture. TRIZ Future 2018. October 29-31, 2018, Insa de Strasbourg, Strasbourg, France.
13. Analogy-based solution search, in “High-priority directions (HPD) for TRIZ development”. <https://matriz.org/wp-content/uploads/2012/09/TRIZ-Development-High-Priority-Directions-Summary-Eng.-100913-VF.pdf>
14. Air France Flight 447. Wikipedia. https://en.wikipedia.org/wiki/Air_France_Flight_447
15. Pulse systems and methods for detaching ice. V. Petrenko. Patent WO 2006/002224 A2.
16. Ice cube tray. Nishimura et al. US Patent 5,346,063 A. Nov. 15, 1994.
17. Clear ice tray. Shapiro et al. US Patent 6,357,720 B1. Mar. 19, 2002.
18. J. Hasi et al. Active beam attenuators for synchrotron radiation. 2012 IEEE Nuclear Science Symposium Anaheim, CA, October 20 - November 2, 2012. 3 pages. <https://www.slac.stanford.edu/pubs/slacpubs/15250/slac-pub-15283.pdf>

Communication

Communicating Author: stephane.savelli@mpsolving.com

TRIZfest 2019

September 11-14, 2019. Heilbronn, Germany

AN ANALYSIS OF 40 YEARS TEACHING ENLARGED TRIZ IN VIETNAM

Minh-Dang Doan^a

^a*University of Freiburg, Freiburg, 79100, Germany*

Paper Classification:

- Educational methods and experiences

Abstract

We studied the outcomes of a program for teaching enlarged TRIZ which was run continuously in more than 40 years in Vietnam. The enlarged TRIZ was twofold: the training has TRIZ together with non-TRIZ topics, and the learners comprise of both technical and non-technical backgrounds. We analysed final reports of learners in order to answer major concerns in TRIZ pedagogy: What ways of enlarging TRIZ are useful? How effective is enlarged TRIZ for people of different backgrounds? Results showed that the enlarged TRIZ courses were greatly useful for learners, TRIZ techniques made more impression than non-TRIZ techniques, and the content was grasped equally well between technical and non-technical learners.

Keywords: *TRIZ in education, enlarged TRIZ, effectiveness of TRIZ learning, creativity techniques.*

Introduction

When TRIZ started to gain popularity and convinced engineers in the former Soviet Union that there exists an invention algorithm, Genrikh Saulovich Altshuller continued to develop the inventive thinking theory to benefit a broader audience, leading to the Theory of Creative Personality Development (TRTL) and the General Theory of Powerful Thinking (OTSM), more details could be found in the summary of Nikolai Khomenko [1]. In 1977, Phan Dung started to teach “enlarged TRIZ” [5] based on classical TRIZ that he had learned directly from G. S. Altshuller. Later, Phan Dung founded the Center for Scientific and Technical Creativity (CSTC) as a unit of Ho Chi Minh City University of Natural Science, Vietnam, which focuses on teaching enlarged TRIZ and disseminating TRIZ to public audiences, under the name “Creativity and Innovation Methodologies” (CIM).

Up to now the CSTC has taught more than 20,000 participants through more than 500 basic and intermediate CIM courses (60 instructional hours per course). The trainees include high school and university students, workers, engineers, teachers, scientists, managers, lawyers, physicians, pharmacists, artists, sport trainers and so forth from all economic and social sectors. Their ages

range from 15 to 72, with education levels from secondary school to Ph.D. The development of CSTC and its training programs was reported in several papers of Phan Dung, see [2], [3], [4].

The training of CSTC was unique, as it could maintain a relatively stable syllabus over 40 years. This long time span of CSTC helps our research to find reliable facts about the effectiveness of this training program. We summarize hereby main blocks in the chronological order of the basic CIM course [6] that we will provide analysis in the next sections:

- 1 Introduction of basic concepts, Creativity and Innovation Methodologies as a science (4 hours)
- 2 Natural method of problem solving and decision making (Trial and Error Method), and an urgent need for inventing creativity and innovation methodologies; introduction of main ideas, structure of TRIZ, as well as knowledge sources, creativity levels in the view of TRIZ (6 hours)
- 3 Scientific and technological knowledge sources of TRIZ, with the topics: information transforming model of thinking process of problem solving and decision making, dialectics, logics, system and systems thinking, psychological inertia and system inertia, history of TRIZ and its relation to patent information in creating TRIZ (12 hours)
- 4 Basic creativity principles of TRIZ, including: technical and physical contradictions, the program of logically reconstructing the thinking process for available solutions, 40 basic creativity principles, matrix of basic creativity principles for resolving technical contradictions, system of transformers (separation principles) for resolving physical contradictions, and a reduced program of problem solving and decision making (18 hours)
- 5 Overview of methods of activating creative thinking, including method of focal objects, morphological analysis method, check-listing method, brainstorming, synectics (method of using analogies) (8 hours)
- 6 The laws of system evolution (10 hours)
- 7 Review of the basic CIM course and preview of the intermediate CIM course (2 hours)

Note that there were some minor changes in the course syllabus, as well as the enrichment of examples that instructors gathered over the years. One of such changes is about the introduction of ARIZ in the course: in the early courses CSTC also demonstrated how to use ARIZ, without dedicated time for doing exercises due to the lack of time; later Phan Dung replaced it by a reduced ARIZ procedure, including some problems and exercises, hence the topic ARIZ was moved to an “advanced CIM” course. More details on updating CIM course content could be found in [3].

1 Data collection and analysis

1.1 Course reflections by CIM participants

After each CIM course at CSTC, every participant was asked to make a final report as a condition for obtaining course certificate, with a general guide asking why they decided to take the course, whether they have applied or planned to use knowledge and skills they learned from the course and initial results, how did they evaluate such knowledge and skills, and their suggestions in improving the teaching of Creativity and Innovation Methodologies. Most of

them wrote what they found useful, their experiences in self-development in the light of systematic knowledge they have learned, their intentions to use such knowledge, etc. Many of them also expressed their positive emotions with what they have learned and discovered during the course.

In the following, we quote a few typical reports, written in English or otherwise translated:

My present job doesn't sound to be one that has anything to do with science and technology. With the tools that I have learned, I have made various designs of new blouses, some of which I find really good. Though I have no plans to become a fashion-designer in the future, this ability to design new models of clothes can help me become an owner of a well-known dress-making shop. Also, thinking methodically will help me work more efficiently with a program carefully envisaged from A to Z, with no redundant operations that waste my time. If I had attended the CIM course right after I finished high school, my career prospects at that time must have been different.

(N.T.M.D. - Dress-maker)

To illustrate, below I will describe one of my successful efforts since I finished the CM course at the CSTC:

Company Fujitsu sent over 210 Vietnamese to Japan for training. After they had been in Japan for a while, once a week the company arranged for some of them to talk with their families via television bridge. Once there was a technical problem: the participants could only see one another's faces without any sound.

Our manager had decided to postpone the meeting. This meant that the families should return home and come back in a week. Among them there were many from very far provinces. Remembering the point "Using the intrinsic resources inherent in the given system" (principle Self-service) in the CM course, I came up with an idea: participants talk on the international telephone of Fujitsu's net while seeing one another on the television screen. All trainees and their families were happy. Because of this, I also felt happy.

(T.T.T.C. - Employee, Company Fujitsu)

A two-month course for introduction to a science was quite short. Nevertheless, the CIM course has equipped me with a new knowledge, a new view point for thinking about problems that was not unilateral as before, in other words it trained me to get rid of "psychological inertia". Although I'm just a beginner in this field, I believe that initial knowledge acquired in the course will always be with me whenever I face a problem, so that to treat it with directed thinking.

I have made first applications of this knowledge in my professional works. I have outlined "check-list questions" for asking my customers and solving their problems in the legal process with basic creativity principles that I learned from the course...

(N.D.T. - Lawyer)

I am glad and very thankful for attending this extraordinary thinking course. After this course I now realize that contradictions could be united and should not be viewed separately. Instead of treating opposite elements as attacking each other, now with TRIZ both are combined to resolve problem in "win-win" situation.

TRIZ methods encourage me to see things and analyze problems objectively. There is no trial and error which is considered wasting time giving limited output. Your methods are convenient to our daily life.

(M.H.Z. - Educational administrator, Ministry of Education, Malaysia)

1.2 Phan Dung's book about the meaning of teaching enlarged TRIZ

In 2017, Dr. Phan Dung has published a book [7] that summarized the strategies and contributions of CSTC to teaching TRIZ-based creativity in Vietnam via such CIM courses. In the first part of this book, Phan Dung explained his reasoning in educating happy people by equipping them the capability to analyze the world systematically and tools to resolve their daily problems, his encounter with TRIZ through direct study with Genrikh Saulovich Altshuller in 1970s - 1980s and the progress of CSTC in building teaching materials and giving courses, including evening classes for 10 - 30 students and invited courses for up to 100 students (in average 40 students/course) and with a low fee (in 2019, the fee is about 50 USD for a 60-hour course, which is approximately 25% of monthly income for an average Vietnamese). In our opinion, the philosophy presented in this first part is worthy for educators, especially those who want to make clear the meaning of TRIZ methodologies to a normal person on their daily life.

The second part of the book presented 337 reports of former students of CIM courses throughout its 40-year history, some of them attended the course as early as course #3, some took the latest course #481 in 2017. This is a valuable resource to evaluate the effects of teaching enlarged TRIZ to enlarged audiences, since there are very few centers in the world that has conducted teaching enlarged TRIZ for such a long time. Although there could have been more reports of former students kept in CSTC's archive, we acknowledge the great effort in digitalizing and publishing the reports in Phan Dung's book, which already took more than 500 pages of the book. This resource provided us data for studying the responses of learners of CSTC's courses, which makes the main content for this paper.

From the unstructured records of students evaluations, we analyzed the texts to figure out each student's impressions over knowledge transferred in the course. We assume that the keywords mentioned explicitly by a student in her/his evaluation were the concepts (or judgements) that impressed her/him the most, and are major outcomes for her/his study. We wrote simple computer programs to do statistics of keywords, then those 337 reports were analyzed manually to confirm the meanings associated with important keywords. We provide the open data set at Github: <https://github.com/rosetta-vn/triz.rosetta.vn/tree/master/research/>.

2 Findings

The analysis of final reports of former CIM learners has shown interesting facts about how much knowledge students had learned from the course, whether there are differences between TRIZ and non-TRIZ contents, and whether there are differences on impacts to learners with and without technical backgrounds. The findings are drawn based on statistical figures, which are presented in the following sections.

2.1 Major impressions about the courses

We first analyzed the most mentioned concepts/judgements in learners' reports, in order to draw a picture about the course from learners' view.

Most impressed concepts

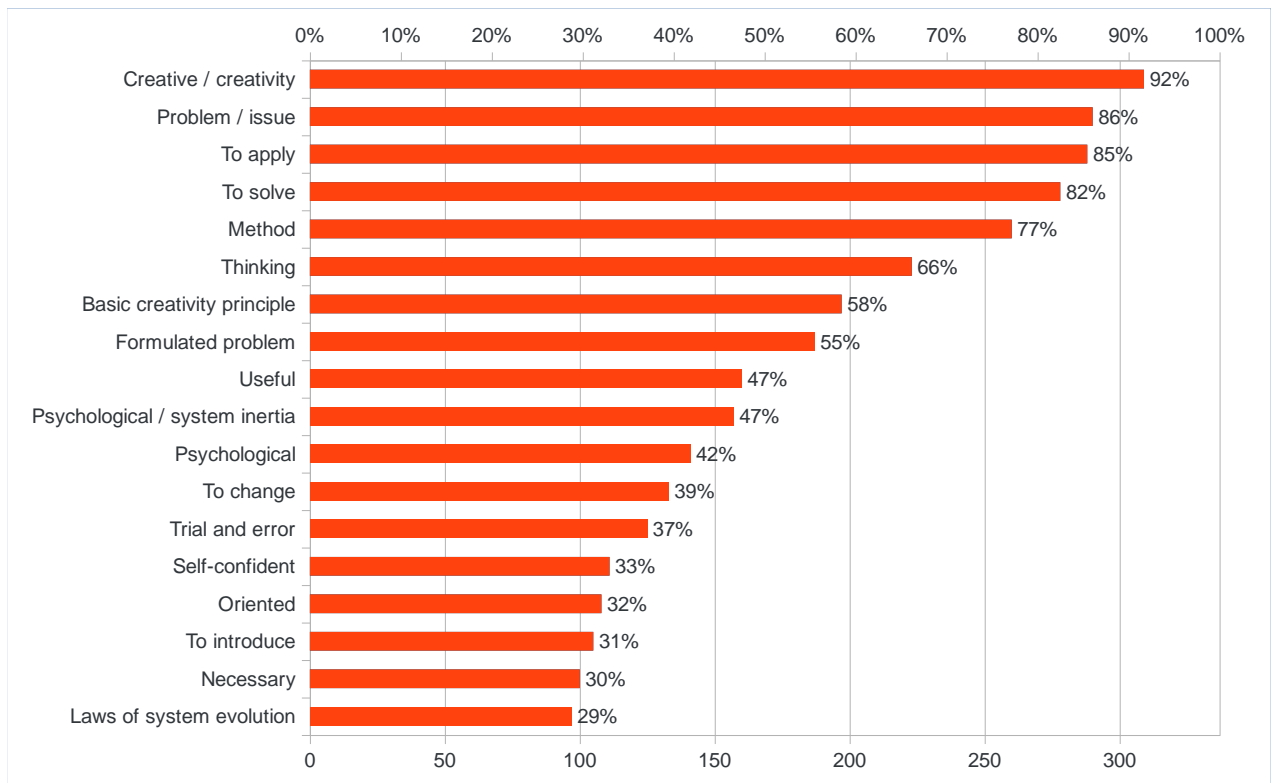


Fig. 1. Most impressed concepts of learners of CIM courses

Most impressed concepts are depicted in Figure 1. Based on the popularity, we can categorize these concepts into three groups:

- The most cited concepts, mentioned in more than 80% reports: “creativity”, “problem / issue”, “to apply”, “to solve”. It is easy to understand almost all learners were concerned with creativity, as it is always a hot topic (for many, also a myth). Knowing that this course program is heavily based on TRIZ, it is understandable that learners associate creativity with solving problems. A surprising result is that most of the learners expressed that they will apply the new knowledge to their own work and daily life problems, some of them were even successful in applying TRIZ techniques to their problems during two months they attended the course. This shows the course has ignited motivation in learners and persuaded them about the practicality of creative thinking techniques.
- From half to three fourths of learners have emphasized concepts: “method”, “thinking”, “basic creativity principles”, and “formulated problem”. This can be interpreted that a majority of learners focused on grabbing thinking methods to deal with problems, and the most remembered methods are from 40 basic creativity principles. We will further investigate how successful of TRIZ methods are delivered to learners, and also zoom in the effectiveness of individual creativity principles.
- About ¼ to ½ of learners are impressed by the concepts: “inertia” (including psychological inertia and system inertia), “trial-and-error”, “oriented”, “laws of system evolution”, which are among the fundamental concepts of TRIZ. Similar amount of learners were aware of “psychological” aspects of creative thinking techniques, they expressed

their evaluation of the course and creativity methodologies at large as “useful” and “necessary”, that helped them “to change” themselves, becoming more “self-confident”, and they would recommend other people to take this CIM course. Note that CSTC did not ask learners whether they would recommend this course, hence about 31% of learners voluntarily promised to introduce the course to other people should be considered a big success.

TRIZ related concepts

Next, we study how TRIZ related concepts were delivered. The result is presented in Figure 2.

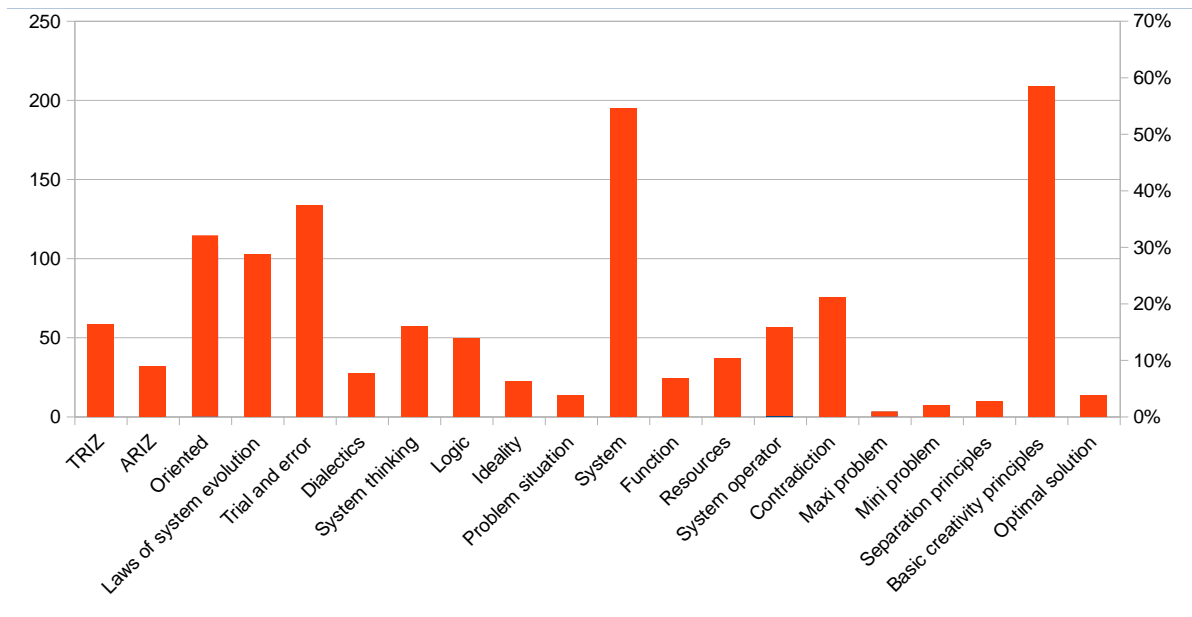


Fig. 2. Numbers and equivalent percentages of TRIZ concepts mentioned in learners reports

Beside the popularity of basic creativity principles, the concept of “system” is also absorbed very well. The name “TRIZ” was not mentioned by in many reports, because the central topic “creativity” has occupied learners’ mind, even though TRIZ is appealing in the lectures. In contrast to “basic creativity principles” and “system”, the concepts of “separation principles” and “function” were rarely acknowledged by learners, partly because they were not emphasized in the lectures, especially separation principles were considered just as regrouping of basic creativity examples and students did not have much time to explore.

2.2 Compare TRIZ and non-TRIZ methods

We now come to comparison between TRIZ techniques and non-TRIZ creative techniques, which were grouped in this syllabus as “methods of activating creative thinking”. In the view point of Phan Dung which is reflected in CSTC’s CIM course content, TRIZ methodologies could cover a vast majority of creative thinking techniques. He has shown that several non-TRIZ creative techniques are just the same as some creativity principles in the TRIZ language [5]. Hence, unlike in other places where the “methods of activating creative thinking” (such as the method of focal objects, morphological analysis method, check-listing method, brainstorming, and synectics) are often classified as non-TRIZ methods, CSTC’s trainers introduce these methods with links to TRIZ and list them as part of the “enlarged TRIZ body of knowledge”.

Figure 3 shows that TRIZ techniques outperformed non-TRIZ techniques significantly, while the time spent for these two groups of techniques was approximately equal. We could explain that TRIZ techniques did a better job because they were taught in a TRIZ-based framework, with more linking and coherences among TRIZ concepts, while each of the non-TRIZ methods were treated independently.

From this figure, we also see that the learning of technical and non-technical learners are similar. We classified learners into the group with “technical backgrounds” if they have either natural science or technical backgrounds, and the rest were grouped “non-technical backgrounds”. In 337 reports that we have analyzed, there were 103 with technical backgrounds, and 234 in the other group.

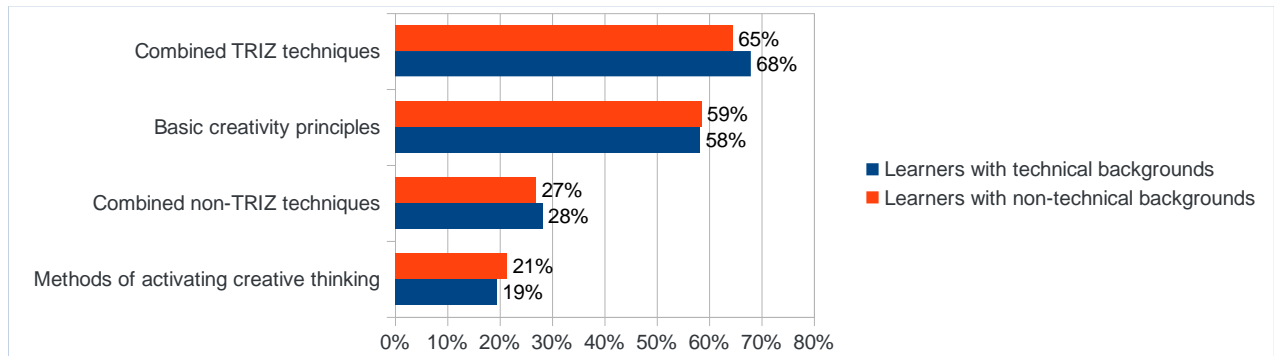


Fig. 3. Comparison of TRIZ and non-TRIZ techniques

2.3 Compare the study of learners with and without technical backgrounds

We now investigate how technical and non-technical learners absorbed the individual creativity techniques. The result is shown in Figure 4, for the better half of 40 basic creativity principles, in comparison to individual non-TRIZ techniques. Although 40 basic creativity principles were formulated using the technical language, it is clear that some principles were popular in general contexts and learners could quickly use, e.g. merging, beforehand cushioning, segmentation, continuity of useful actions. More surprisingly, there are several creativity principles that non-technical learners absorbed better than their technical fellows, such as: periodic action, turning harm into benefit, taking out, universality. This could be due to the flexible mindset of non-technical people, which allows them to make use of new concepts easier than technical people, also note that the teaching of many basic creativity techniques were supported by general, easy to understand examples.

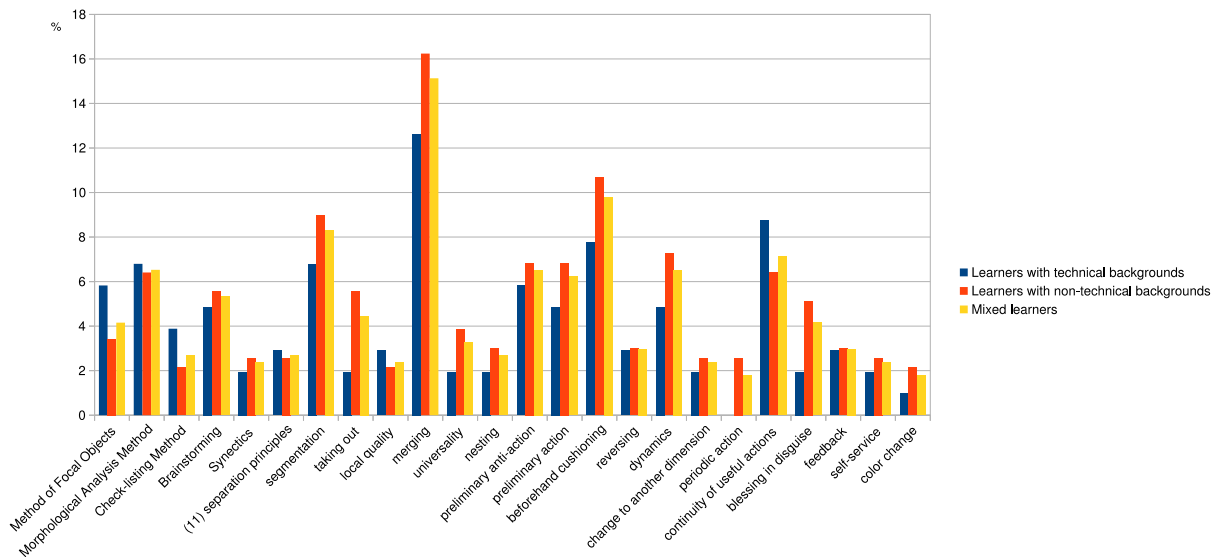


Fig. 4. Percentage of learners mentioned basic creativity principles (principles with less than 2% learners mentioned were omitted)

3 Conclusions

This paper presents an analysis of teaching enlarged TRIZ, with data collected throughout 40 years of teaching “enlarged TRIZ” in Vietnam. We have analyzed major accomplishment of this program in terms of most impressed concepts/judgements of its learners, there were clear evidences that TRIZ concepts are received better by learners, and both learners of technical backgrounds and of non-technical backgrounds could follow this program equivalently. These findings confirm that it is not a problem to teach TRIZ concepts to non-technical people, the inclusion of non-TRIZ techniques requires more effort to integrate them into a TRIZ-based training program, and basic creativity principles are the most straightforward techniques for beginners to learn and to apply in daily life.

A number of learners have soon applied newly-learned techniques to their problems while they were attending the course. However until now, there is little data about how they used enlarged TRIZ knowledge after the course. We expect to perform extended research in collecting data from past learners of CSTC’s courses and analyzing the long-term results of the training.

Acknowledgment

We would like to thank Dr. Phan Dung, former head of the Center for Scientific and Technical Creativity, for the discussion about the process of teaching enlarged TRIZ at CSTC and his encouragement for this study. We would like to thank the team of CSTC for providing data for this research.

References

1. Nikolai Khomenko. “Fundamentals of Classical TRIZ.” N. Khomenko’s archive, 2008. Available at: https://otsm-triz.org/sites/default/files/ready/1a_-_introduction_to_classical_triz__teachers_and_adult_trainees_.pdf
2. Phan Dung. “Introducing Creativity Methodologies into Vietnam.” Creativity and Innovation Management, V. 3, No 4, 240-242, UK, 1994.

3. Phan Dung. "On the Basic Program "Creativity Methodologies for Problem Solving and Decision Making" Being Taught by the Center for Scientific and Technical Creativity in Vietnam." In Morris I. Stein (ed.) *Creativity's Global Correspondents - 1999*, Florida Winslow Press, USA 250 – 256.
4. Phan Dung. "Some Results Derived from Teaching the Course "Creativity Methodologies"." In Morris I. Stein (ed.) *Creativity's Global Correspondents*, pp. 205-212. Florida, Winslow Press, 2000.
5. Phan Dung. *Enlarging TRIZ and Teaching Enlarged TRIZ for the Large Public*. Keynote paper presented at the International Conference "TRIZCON 2001", Woodland Hills, California, USA, March 25-27, 2001.
6. Educational programs of Center for Scientific and Technical Creativity. Available at: <http://cstc.vn/index.php/en/educational-programs.html>
7. Phan Dung. "Innovating education and training: building happy people through creativity (some results obtained in the past 40 years)." Ho Chi Minh City , Youth Publishing Co., 2017. (in Vietnamese)

Communication

Communicating Author: minhdang@doan.vn, dang.doan@imtek.uni-freiburg.de

TRIZfest 2019

September 11-14, 2019. Heilbronn, Germany

APPLICATION OF SYSTEMATIC INNOVATION METHOD IN BF HEARTH EROSION PROBLEM

LIU Yongmou^a Zhong Xingli^b

^a GET Group, Chengdu, 610041, Sichuan, China

^b CISDI Engineering Co., Ltd., Chongqing, China

Paper Classification:

- Case study

Abstract

Blast hearth is a key component in a blast furnace for its status in-service condition will greatly and directly impact the longevity of a blast furnace. Therefore, how to monitor the status of the hearth in operating and to lengthen its service period has become the key factor for the campaign of a blast furnace, which will greatly impact the survival, development and competitiveness of an iron and steel enterprise. In the past 20 years, lots of research and efforts have been made on failure mechanism and monitoring the status of hearth in real time. But unfortunately, most of the methods for monitoring the status of hearth in real time are of indirectly and high deviation. This paper, from a new perspective, proposed a new model and a series of inventive solutions for monitoring the status of hearth in real time and the recommendations to extend the campaign of hearth by means of modern systematic innovation method and furthermore, one of result has been evaluated by means of CAE.

Keywords: *Hearth of Blast Furnace, Erosion, TRIZ, Function Model, Su-Field, Standard, CAE*

1 Introduction

Blast hearth is a key component in a blast furnace for its status in-service condition will greatly and directly impact the longevity of a blast furnace. Therefore, how to monitor the status of the hearth in operating and how to lengthen its service period has become the key factor for the campaign of a blast furnace, for which it will greatly impact the survival, development and competitiveness of an iron and steel enterprise. In the past 20 years, a lots of research and efforts have been made on failure mechanism and monitoring the status of hearth in real time.

1.1 CECA Research on the failure mechanism of blast hearth

As a black box [1], the most researching reports on the failure mechanism of blast hearth are proposed by means of hypothesis. These of hypothesis can be shown in a CECA Model, See Fig1 for Details.

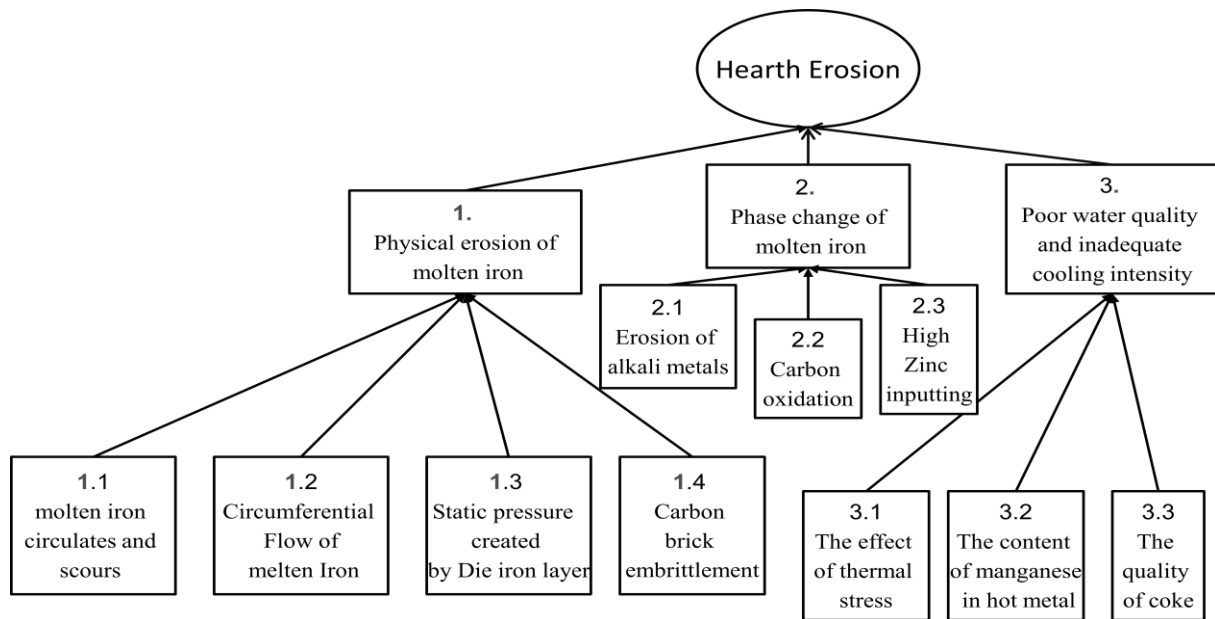


Fig1. CECA Model of the Hearth Erosion [2]~[8]

1.2 The developed ways to monitor the status of hearth in real time

According to the conditions of thermal measurement in the blast hearth, the three categories of the blast hearth has been defined [1], which are category1 (with two layers of thermocouple within the hearth), category2 (with single layer of thermocouple within the hearth) and category3 (with none of thermocouple within the hearth but only pipeline for cooling with water). Therefore, the developed methods for monitoring the status of the hearth in real time could be classification into three categories accordingly [1].

- 1 Category 1: Measuring the temperature on two thermocouples located at the same level or same circle in the hearth and working out the isothermal point of 1150°C based on the thermal conductivity theory for large flat plates and long cylinders (linear model), and then, monitoring the left thickness of the bricks within the hearth. [9],[10],[11],[12],[13],[14],[15],[16],[17],[18]
- 2 Category 2: Measuring the temperature on the existing thermocouples and working out the isothermal point of 1150°C on the equation of the thermal conductivity theory for solid (2 dimensional model) by means of finite element method (FEM), finite difference method(FDM) , boundary method(BM) , etc. Also monitoring the left thickness of the bricks within the hearth. [20],[21],[22],[23],[24],[25]
- 3 Category 3: Measuring the temperature of the inlet and outlet of the cooling water and based on the difference to monitoring (or guess) the left thickness of the bricks within the hearth. [26],[27],[28],[29],[30],[31]

Given the above, it is worth noting that no matter the failure mechanism of blast hearth or the ways to monitor the status of hearth in real time, the current study and related means was based on some hypothesis and the subsequent statistical analysis for the existing blast furnace. It will be necessary to rebuild the problem model of the hearth for people to analysis and to develop more directly method to monitor the status of the hearth in the really real time.

2 Problem Model and the Problems Recognized

2.1 Problem Model

A typical structure of the blast hearth is shown in Fig.2. Based on this structure, we could build the system function model. Shown in Fig.3.

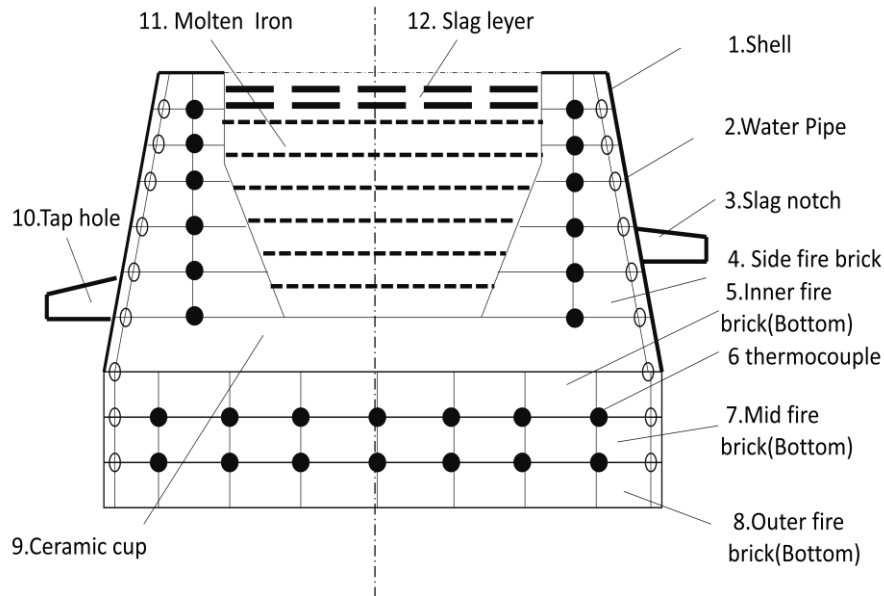


Fig. 2. Schematic Diagram of hearth Lining Structure

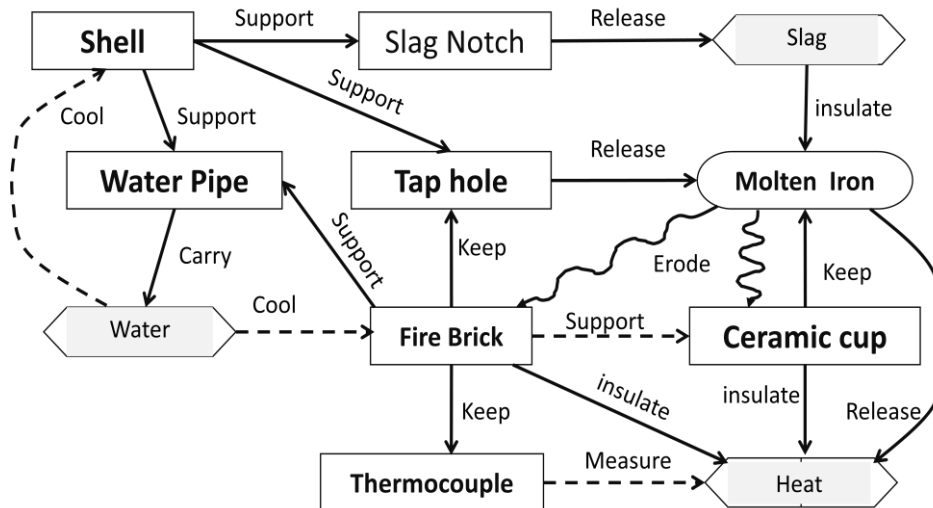


Fig. 3. Function Model of the blast hearth

2.2 Problem Recognized

In diagram Fig.3, the problems to be solved within the hearth are of obvious, they are listed as following:

1. How to avoid or reduce the erosion between the molten iron and the ceramic cup and the fire bricks?
2. How to increase the measurement accuracy of the thermocouple?
3. How to improve the cooling effect of the water to the shell and the fire bricks?
4. How to enhance the supporting role of the fire bricks to the ceramic cup?

3 Results and Discussion

Based on the System of Inventive standards of TRIZ, the problems figure out in system function model could be solved as follow.

Problem 1: How to avoid or reduce the erosion between the molten iron and the ceramic cup and fire brick? The problem's Su-field model (SFM) is shown in Fig.4.

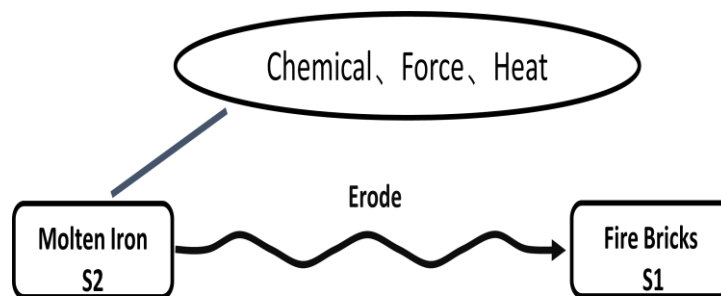


Fig. 4 Su-field Model of Problem 1

Problem-Solving Thought: According to the System of Inventive standards of TRIZ, There are two standards (ideas) are suggested: [33]

1. Standard 1-2-1: If useful and harmful effects appear between two substances in a SFM and there is no need to maintain a direct contact between the substances, the problem is solved by introducing a third substance between them.
2. Standard 1-2-4: If useful and harmful effects appear between two substances in a SFM and a direct contact between the substances must be maintained, the problem can be solved by transition to a dual SFM, in which the useful effect is provided by the existing field while a new field neutralize the harmful effect (or transforms the harmful effect into a useful effect).

Usage Scenario: Based on the Problem-solving thought suggested by System of Inventive standards of TRIZ, a series of scenarios are gotten as follows:

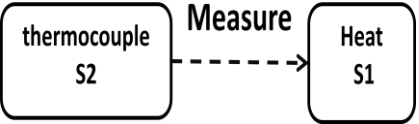
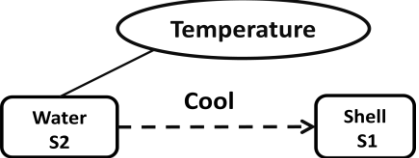
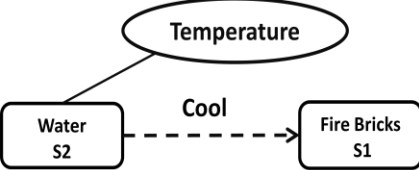
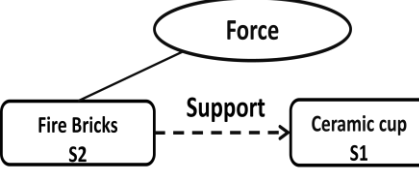
Scenario 1: Introducing some kind of material (film) which has higher melting point than iron as the third substance between the molten iron and the fire bricks. The materials could be graphite (melting point $3652^{\circ}\text{C}\sim 3697^{\circ}\text{C}$), high temperature ceramics (melting point $>1702^{\circ}\text{C}$), etc.

Scenario 2: Introducing the cooling water as the new field to neutralize the harmful effect of the heat, which means the pipe line could be build within the inner fire bricks.

Scenario 3: By means of the pipe line build within the inner fire bricks, the water will cool the molten iron and the cold iron could be taken as the third substance to isolate the harmful effect between the molten iron and the fire bricks.

The other problems solving results are list in Table 1.

Table 1

Problems	SFM of the Problem	Problem-Solving Thought	Usage Scenario
<p>How to increase the measurement accuracy of the thermocouple?</p>		<p>1、 Standard 4-3-1: Efficiency of a measuring SFM can be improved by the use of physical effect.</p>	<p>Scenario 4: Replace the thermocouple by introducing brass (Melting Point 1083°C) or Grey pig iron (Melting Point 1200°C) as the warning shell in the fire bricks.</p>
<p>How to improve the cooling effect of the water to the shell?</p>		<p>1. Standard 2-1-1: Efficiency of SFM can be improved by transforming one of the parts of the SFM into an independently controllable SFM, thus forming a chain SFM.</p>	<p>Scenario 5: Introducing some Volatile matter such as dry ice to improve the cool efficiency.</p> <p>Scenario 6: Change the shell from solid into the honeycomb structure and introducing wind to improve the efficiency of cooling.</p>
<p>How to improve the cooling effect of the water to the fire bricks?</p>		<p>2. Standard 2-1-2: If it is necessary to improve the efficiency of the SFM, and replacement of SFM elements is not allowed, the problem can be solved by the synthesis of a dual SFM through introducing a second SFM which is easy to control.</p>	<p>Scenario 7: Introducing some Volatile matter such as dry ice to improve the cool efficiency</p> <p>Scenario 8: Change the bricks from solid into porous and introducing wind to improve the efficiency of cooling.</p>
<p>How to enhance the supporting role of the fire bricks to the ceramic cup?</p>		<p>3. Standard 2-2-1 : Efficiency of SFM can be improved by replacing an uncontrolled (or poorly controlled) field with a well-controlled field.</p>	<p>Scenario 9: Change the Ceramic Cup from solid into the honeycomb structure to improve the strength of Cup.</p>

So far, by means of TRIZ method, 9 solutions have been gotten. Among of these solutions, scenario 4 is a new, directly and timesaving method for monitoring the status of the blast hearth in really real time, as it is well-known that the freezing temperature of iron is 1150°C and the temperature is widely used to determine the index of the erode status of the hearth, so the brass (melting point 1083°C) or grey iron (melting point 1200°C) could be used as a indicator of the erode of the bricks. The result of the simulation by CAE software is shown in Fig.5. and Fig.6.

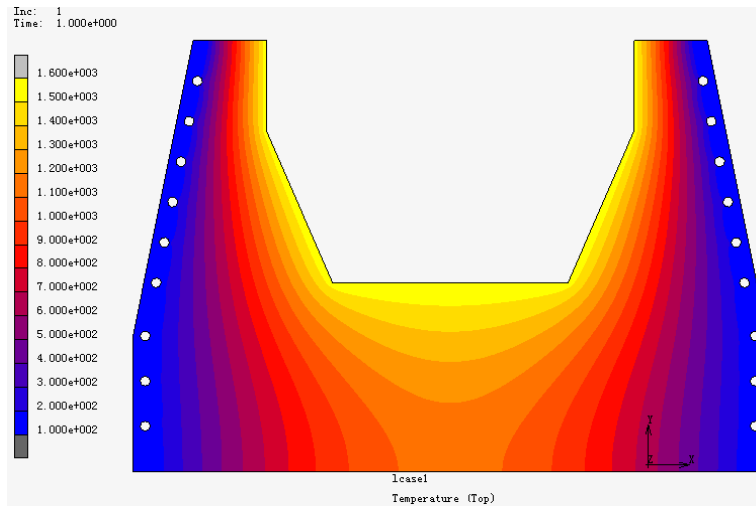


Fig. 5 Temperature field nephogram of the hearth

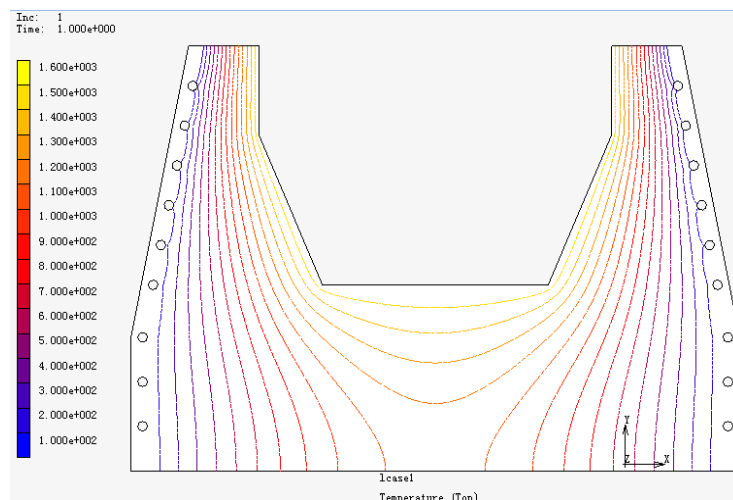


Fig. 6 The Temperature isoline of the hearth

From the result of CAE simulation, we think that take the brass or grey iron could be used as an indicator of the erode of the bricks in the hearth is feasible. The other scenarios or solutions are based on the resources such as dry ice, wind, etc. which is easy be acquired or freely.

4 Conclusions

Modern systematic innovation including TRIZ as a powerful toolkit is very useful for solving the problems in industries. The author of this paper just tried something useful in hearth eroding problem, a lot of deeply research could be done in the future.

References

1. CHEN Liangyu, A review on the new techniques of erosion analysis and monitoring in bf, Proceeding of the small and middle blast furnace of 2007 Annual Meeting, p13, 2007
2. Liu Tao New No.1 blast furnace hearth wear analysis and production practice, Thesis for Master's Degree, University of Science and Technology Liaoning, p13, June, 9, 2016
3. Wang Bo, Hua Jianming Bao Steel No.1. blast furnace hearth corrodes analysis and countermeasure, Ironmaking, p30, Vol.35 No.3, June, 2016
4. DU Ping, LEI Ming, LIU Jian bo, TAGUCHI Seiji Effect of BF Operation on Hearth Erosion, Iron and Steel p9, Vol.47 No.12, December 2012
5. CHE Yu-man WANG Bao-hai XIE Ming-hui CUO Tian-yong SUN Peng YAO Shou CHEN Cuo-yi, Blast Furnace Hearth Erosion Nature and Reasons IRONMAKING, p26, Vol.31 No.4 August 2012
7. HU Chun-mei YANG Dao-bin SUN Lin-ju LAO Dong-hai GUO Chang-ji, Erosion Study of Nan Steel Blast Hearth and bottom, IRONMAKING p59, Vol 32.No.2 April 2013
8. LIN Liangcheng, ZOU Zhongping, NIU Weijun, LI Aifeng, YANG Yun, Influence of manganese content in hot metal on hearth erosion of blast furnace, Research on Iron & Steel, p30, Vol.45 No.1, Feb. 2017
9. REN Zhendong, YU Haixin, IRONMAKING, Erosion reason and protecting means for Tong Steel No.3 Blast furnace hearth, p53, Vol.36, No.1, February 2017
10. ZHANG Liuyu, XIA Shitong, WANG Chongpeng, GUI Xuefeng, ZHU Qianfu, Annual analysis of erosion situation in 1000 m³ blast furnace, Research on Iron & Steel, p57, Vol.43, No.4, Aug. 2015
11. WANG Chongpeng, FENG Xuewu, SU Lili, Analysis of Erosion Situation of Hearth in 1080 m³ Blast Furnace, FOUNDRY TECHNOLOGY, p218, Vol.36, No.1, Jan. 2015
12. LI Fangkun, Development and Application of Monitoring System of BF Hearth Erosion, p55, Vol.37, No.5, October. 2015
13. WU Lijun, CHENG Huier, MA Xiaodong, SONG Canyang, Mathematical Model for Prediction of Bottom and Hearth of Blast Furnace by Boundary Element Method, JOURNAL OF SHANGHAI JIAO TONG UNIVERSITY, p1733, Vol.38, No.10, Oct. 2004
14. JHUANG Yongdong, Applying finite element method to model and predict erosion of the hearth and bottom of blast furnace, Metallurgical Industry Automation, p30, Vol.34, No.3, May. 2010
15. XUN Jun, ZOU Zhongping, HU xianbo, The application of the Erosion Model of the hearth, Iron and steel Technology, p5, May, 2010
16. ZHOU Liying, WANG Ping, Li Jiabin, ZHAO Qingchun, Online application of hearth lining erosion model for No1 BF at Ma Anshan Iron & Steel Co Ltd, Automation of metallurgy, P25, Feb. 2005
17. LING Yun, GUAN Chunyan, The analysis of the Nan steel No.4 Blast Furnace's hearth forecast model of the erosion, Proceeding of the small and middle blast furnace of 2007 annual Meeting, p396, 2007
18. GUO Hui, DING Yuehua, Influence of harmful elements on hearth erosion of No.3 blast furnace in Honghe Iron and Steel Co., Ltd, Research on Iron & Steel, p40, Vol.42, No.1, Feb. 2014

19. Wu Lijun, CHENG Huier, SONG Canyang, Methodology of Building Mathematical Model for On-line Prediction of bf Hearth and Bottom Erosion, IRON AND STEEL, p5, Vol.37, No.12, Dec. 2002
20. LI Zhaoyi, GU Xianglin, AO Aiguo, Development and Application of On-line Erosion Monitor Model to 2BF Hearth at Baosteel, Baosteel Technology, p48, Vol.3 2002
21. CHEN Liangyu, LI Yu, WU Hulin, Application of Two Dimensional Method to Blast Furnace Hearth Erosion Modelling, Iron and Steel, p12, Vol.43, No.8, Aug. 2008
22. ZHUANG Yuru, DING Rucai, Development and Application of Erosion Model for Blast Furnace Hearth and Bottom, Automation of metallurgy, p33, Vol.2 , 1997
23. DAI Fangqin, ZHANG Fahui, Development and Application of Hearth and Bottom Erosion Model, p255, Proceeding of The 8th national annual conference on energy and thermal engineering
24. Wu bin, Research on Monitoring Model for the Erosion of Blast Furnace Hearth, Thesis of BS, University of Jiangsu Science and technology, p16, June, 2014
25. JIAN Ling, ZHANG Jiansong, SONG Yunquan, ZHAO Min, Numerical simulation of blast furnace hearth erosion based on finite difference method. Computer Engineering and Applications, Computer Engineering and Applications, p29, Vol.9, 2012
26. SUN Shouqun, LUAN Benyan, LU Huayang, Application of quasi-3D method to calculation of erosion for shaft section of lining of blast furnace hearth, p25, Vol.27, No.12, Dec. 2015
27. TAO Ling, NIE Changguo, CAO Hai, WANG Ping, Development and application of hearth and bottom erosion monitoring model for 2 500 m³ blast furnace, esearch on Iron & Steel , p48 Vol.44, No.4, , Aug. 2016
28. CHEN Liang-y u , LI Y u , WANG Zi-jin , ZHANG Ming, Application of Inverse Solution to Boundary of Heat Transfer in Erosion Diagnosis of Blast Furnace Hearth, Journal of Northeastern University(Natural Science), Vol.30, No.8, p1136, Aug. 2009
29. LIU Wei, ZHAO Zhichun, LI Wenzhong, CHEN Yibiao, Mathematical Model for Monitoring Erosion of Blast Furnace Bottom, IRON AND STEEL, p51, Vol.31, No.10, Oct. 1996
30. WANG Changsen, Three-dimensional Erosion Diagnosis Technologies and Calculating System Development for Hearth Lining in Blast Furnace Modelling, Thesis for Master 's Degree , North-Eastern University, p20, June.2013
31. HUANG Yaming, Furnace Erosion Based on Water Temperature Difference of Blast Furnace Cooling Stave, industrial control computer,, P25, Vol.28, No.7, 2015
32. ZHANG Baofu, LIU Haibin, LIU Fucheng, ZHAO Hongbo, HUO Shoufeng , Study on hearth erosion based on tinny water temperature difference monitoring, p18, Vol.42, No.6, 2014
33. HUANG Xiaoyu, XUE Xiangxin, Iron Steel Res. P2, Vol 33 No.3 (1998).
34. Valeri Souchkov, The Glossary of TRIZ and TRIZ-Related Terms, the International TRIZ Association - MATRIZ, 2014
35. Yuri Salamatov, TRIZ: The right Solution at the Right Time., p. 232–233. Insytec B.V. 1999

Communication

Communicating Author: michael.liu@get-technologys.com

TRIZfest 2019

September 11-14, 2019. Heilbronn, Germany

APPLICATION OF TRIZ TECHNIQUES FOR IDENTIFYING IDEAS FOR DIGITAL ANTI-TROLLING

Hiltmann Nadiya, Hiltmann Kai

University of Applied Sciences, 96450 Coburg, Germany

Paper Classification:

- Best practices, business experiences, integration with non-TRIZ methods/tools

Abstract

This report presents examples of using TRIZ techniques for searching solutions to the problem of cyberwar like propagandistic trolling or troll army on the internet and in social networks.

The general concepts of cyberwar and internet trolling are briefly clarified first. Then three TRIZ tools will be presented along with approaches for the development of means for digital anti-trolling. The purpose of this work is to show a possibility of use of the TRIZ equipment for idea generation to create protective measures against propaganda trolling.

Keywords: *TRIZ techniques, cyberwar, anti-trolling*

1. Project

1.1. Cyberwar

Digitization has fundamentally changed our lives in just a few years. Networked electronic devices have become an integral part of people's everyday lives and work. Digitization opens up opportunities, but also carries risks and dangers.

With the information age, the age of hybrid wars has begun. In addition to military means, digital means are now also being used [1]. The term of cyberwarfare refers to the cybernetic forms of war that are based on the computerization and networking of all civil, political, economic and military spheres [2]. Digital propaganda and digital disinformation are among the most important factors in the emergence and evolution of the war in the modern cyber world.

The most common forms of human and automated cyber disinformation profiles are bots, bot-nets, fake accounts, chat bots, spam bots, fake news, trolls and troll armies [3].

1.2. Trolling

Troll is a web jargon for Internet users who are struck by provocation, disruption, insults in network communications. Trolls usually operate under a pseudonym or anonymously and they use the anonymity of the Internet to annoy others with destructive comments [4].

Behavior patterns of trolls: hiding their virtual identities; acting deliberately, repeatedly and detrimentally; ignoring and violating principles; causing content damage and conflicts [5].

The term of troll army or cyber troops denotes a covert organization that operates the disinformation on the Internet on behalf of the state or the interest group. Cyber troops are employed by government, the military or political parties to manipulate public opinion through social media [6].

The term of cyber troops was primarily used for a Russian disinformation strategy. Russian government has installed a so-called Internet research agency, which represents the government's position in comments on media sites and coordinates or dispels criticism of the government on social media [6]. China used a similar strategy with the "50 Cent Army", which wrote comments in the spirit of the Communist Party [7]. The US Army and the British intelligence service GCHQ also run programs that use strategies of troll armies [3].

Organized social manipulation takes place in many countries of the world. It has frequently been reported in connection with cyber troops that are installed using public money [6]. In authoritarian regimes, social media propaganda campaigns are funded and coordinated by the government. In the democratic world, political parties use innovative, digital communication technologies for the manipulation of social media in their own interest.

Examples of actions of troll armies that became public are: The Crimea "referendum" (2014), Russian-Ukrainian war (since 2013), election of the US president (2016), Brexit (2016), French election campaign (2017) [1].

Another action of troll armies is influencing public discourses on commercial products by PR agents under false names. This includes positive product descriptions for the customer and the dissipation of product criticism.

1.3. Measures against propagandistic Trolling.

To create countermeasures like anti-trolling, facilities should be formed for announcement, analysis, and active research of incidents as well as for the development of security software. Moreover, citizens can be involved in the defense. Besides, education and information campaigns can help increase computer security [8].

Countermeasures by the EU and NATO: Cyber defense are defensive measures for protection against cyber-attacks and increasing cyber security. They also include countermeasures against misinformation by the troll army [9]. The European Parliament has taken some groundbreaking decisions such as "Joint Framework on countering hybrid threats: a European Union response" [10] and "EU strategic communication to counteract propaganda against it by third parties" [11] to respond effectively to new cyber danger.

In addition, the member states of the EU and the North Atlantic Treaty Organization have agreed on a plan for greater cooperation in cyber-defense [7]. NATO and EU want to expand their cooperation with concrete measures. These include the fight against hybrid warfare and cyberattacks. Thus, a common investigation is also planned by disinformation campaigns against the EU and NATO in social media [12].

International countermovement: At present, only a few civil institutions are currently involved in the development of anti-trolling programs. Google, for example, wants to fight trolls with artificial intelligence. The corresponding program is called "Perspective" and has been developed by the Google subsidiary Jigsaw [13]. As part of the Digital News Initiative, Jigsaw

will provide an interface to allow "Perspective" to be applied free of charge to network users. It should be able to identify and block the harmful comments and discussions of trolls by the help of artificial intelligence. "Perspective" was trained to check and to remove comments depending on their level of "toxicity" [14].

The Computational Propaganda Research Project (COMPROP) explores the interaction of algorithms, automation and politics. This project was founded at the Oxford Internet Institute. The study analyzes the use of social media bots that manipulate public opinion by reinforcing or suppressing political content, disinformation, hate speech and junk news [15].

Absolute cybersecurity is not achievable, an abuse potential will always exist. Nevertheless, it is the duty of the state and of society to lay the foundations for cyber defense and to develop countermeasures such as anti-trolling. The purpose of this work is to show that creative TRIZ methods can be successfully applied to the development of cybernetic defenses.

2. TRIZ

TRIZ is based on the analysis of technical problems and provides a systematic approach to solving technical, inventive tasks. Currently TRIZ is also applied to non-engineering areas, e.g. economic, organizational, social, or information systems. It is therefore suitable in principle for the analysis and solution of questions in any field [16].

Using TRIZ methods, we have analyzed the future evolution of propagandistic trolling and identified several ideas for the development of anti-trolling. The following list summarizes the determined ideas for the target topic.

3. Results.

3.1. Analysis of tendency for trolling by means of the system operator.

The system operator or 9-window analysis is a scheme for system analysis or for problem solution and for estimation of future system evolution. It is intended to perform a complete analysis of a problem situation with regard to the structural system levels (system, subsystem, supersystem) as well as the temporal processes (past, present, future) [16].

The table presents a combined view of all aspects, effects and correlations. The nine windows visualize a systematic consideration of the whole situation. The 9-window analysis can lead to absolutely new solutions, system definitions or problem imaging. Also, system functions, resources, and requirements can be considered [17].

In the 9-window analysis of evolution of the troll army over time as part of the propagandists, the following pattern for the trend of development and future prognosis has emerged:

Table 1

Evolution trends and future prognosis for troll army as a result of the 9-windows analysis

	past	present	future
super-system	ideological state regimes: communist Parties, totalitarian regimes	anti-democratic regimes: post-communist regimes, Islamist regimes	multinational corporations: politics loses importance, transnational corporations

System	party officials	regime propagandists	corporation adepts
subsystem	party members, party ideologists, <u>paid party activists</u>	party members, media propagandists, <u>troll army of the regime</u>	Corporation managers, Corporation media, <u>troll troops of corporations</u>

The analysis points to the expectation that trolling will be increasingly used in the competition between multinational corporations in the future. This requires the development of anti-trolling technologies.

3.2. *Contradiction analysis for anti-trolling*

A technical contradiction is defined in TRIZ as a situation in which one parameter is improved to solve a problem, but another parameter of the same system gets worse substantially [16]. For the solution or for overcoming such contradictions, 50 engineering parameters and 40 basic innovative principles are available, arranged in the so-called contradiction matrix. For the problem solution the user formulates a contradiction and consecutively generalizes it expressing it in the terms of the 50 engineering parameters. The contradiction matrix will then, at the intersection of the row and column corresponding to the two parameters, suggest promising innovative principles to solve the contradiction [17].

Problem formulation: Trolls decrease the truth of information (losses of information); removal of trolls by means of an additional engine will lead to the deterioration of the Internet performance (productivity) as well as the reliability (security). This results in the contradiction formulation:

If one takes an action against the trolls in the form of a cleaning engine, *then* this will improve the truth of the news, *but* it will degrade the overall Internet performance as well as the Internet reliability, because several process steps burden the reliability. Accordingly, the following combinations of engineering contradictions and recommended innovative principles are possible for our task (according to Matrix 2010) [18]:

- engineering parameters: 28 loss of information / 24 function efficiency → principles: 5, 10, 12, 37
- engineering parameters: 28 loss of information / 44 productivity → principles: 5, 10, 13, 24;

From the analysis of the technical contradictions and derived innovative basic principles, the following table with ideas for anti-trolling emerged:

Table 2

Ideas for anti-trolling concept as a result of the contradiction analysis

Nr	principles	ideas, solutions
5	merging	<p><i>Comments are coupled with the user's identification or with an additional tasks:</i></p> <p><i>Commentators have to answer questions of knowledge, solve riddles → consumes time (scarce resource of trolls)</i></p> <p><i>Punishment for trolls; locking of computer IP;</i></p>

10	preliminary action	<i>Time spent on comments should be extended;</i> <i>Comments do not appear immediately, but after filtration;</i>
12	equipotentiality	<i>Increase prestige values of social network members.</i> <i>Troll defense serves the prestige of social networks like Facebook etc;</i>
13	the other way round	<i>Trolls destroy each other;</i> <i>Harmful troll comments lead to destruction of troll account;</i> <i>Trolls spread useful information;</i>
24	"intermediary"	<i>Mediator between comments and readers:</i> <ul style="list-style-type: none"> • <i>human moderators,</i> • <i>digital moderators, intelligent filters,</i> • <i>artificial intelligence for text correction, checking correctness of statements,</i> • <i>no direct comments, but a processor interprets and reformulates;</i> <i>Users have the option to mark troll comments as malicious;</i> <i>Net users participate in anti-trolling as free moderators;</i> <i>Network moderators can block the trolls;</i>
37	thermal expansion	<i>Fight against trolls should be expanded;</i> <i>All users, web operators, government are responsible for anti-trolling;</i> <i>Network users can expand and improve communication rules;</i> <i>Trolls destroy themselves;</i>

3.3. Anti-trolling ideas using the smart-little-people model

The smart-little-people model is a TRIZ tool for system analysis and for idea creation in which the system and possible solutions are represented by the actions of an infinitely number of elements (so-called little people or gnomes) who can possess any ability and show any desired behaviour [16]. From this gnomes-model several ideas for a anti-trolling measures were derived.

Image: Many gnomes on the computer.

Solution idea: Many international network subscribers, terms of use apply worldwide; new, "official" non-anonymous network should be developed;

Image: Gnomes as blood cells. Analogy: Immune system learns to identify and fight viruses.

Solution idea: Troll posts are removed by the "internet immune system";

Image: Gnomes as ants with knowledge elements.

Solution Idea: Swarm intelligence: Building a knowledge base for anti-trolling;

Image: Every PC is a gnome.

Solution idea: Software for eliminating troll comments. Possibility for complaints with web operator;

Image: Every web browser is a gnome.

Solution idea: Every web browser has an analysis system and sends a troll address to web operators;

Image: All users are self-organized gnomes

Solution Idea: Digital gnomes organize themselves into a smart defense system;

Image: All users are creative gnomes.

Solution Idea: All users help with the development and application of the troll defense;

Image: All participants are enlightened gnomes.

Solution Idea: Trolling propaganda does not work anymore when all participants have been informed.

Image: Bots as evil gnomes. How can one distinguish bots from humans?

Solution idea: Identification about efficiency (bots are quicker than humans), the bots account will be blocked.

Image: All users are gnomes.

Solution idea: Gnomes against gnomes → Troll defense in sync with troll attacks

4. Conclusions

The analysis of the trolling problem by means of TRIZ promises that this method can find effective measures for the anti-trolling concept. The 9-window analysis permitted us to estimate a trend of propagandistic trolling which is disinformation trolling by large companies in the future. This again proves the need for the development of anti-trolling concepts. The TRIZ tools employed yielded many new ideas. Table 3 summarizes a selection of potential ideas.

Table 3

Selection of significant ideas for anti-trolling concepts identified by TRIZ methods

Tool	Ideas, Solutions
contradiction analysis	<ul style="list-style-type: none"> • Fight against trolls should be expanded; • All users, web operators, government are responsible for anti-trolling; • Increase prestige values of social network members. • Troll defense serves the prestige of social networks like Facebook etc; • Network users can expand and improve communication rules; • Users have the option to mark the troll comments as malicious; • Network users participate in anti-trolling as free moderators; • Network moderators can block the trolls; • Mediators between comments and readers: <ul style="list-style-type: none"> ○ human moderators, ○ digital moderators, intelligent filters, ○ artificial intelligence for text correction with correct statements, ○ no direct comments, instead "Siri" reformulates clean interpretation; • Time spent on comments should be extended; • Comments should be coupled with the user's identification or with an additional tasks: • Commentators should answer knowledge, understanding questions;

	<ul style="list-style-type: none"> • Comments do not appear immediately, but after filtration; • Harmful troll comments lead to destruction of troll account; • Punishment for trolls; locking of the computer IP of trolls; • Trolls destroy each other; • Trolls spread useful information;
smart-little-people	<ul style="list-style-type: none"> • Many international network subscribers, terms of use apply worldwide; new, "official" non-anonymous network should be developed; • All users help with the development and application of the troll defense; • Swarm intelligence: Building a knowledge base for anti-trolling; • Digital gnomes organize themselves into a smart defense system; • Trolling propaganda does not work anymore when all participants have been informed. • Troll post by the "internet immune system" remove; • Every web browser has an analysis system and sends a troll address to WEB operators; • Software for eliminating troll comments. Possibility for complaints with WEB operator; • Identification about efficiency, the bots account will be blocked. • Gnomes against gnomes → Troll defense in sync with troll attacks.

Some of these ideas and solutions can certainly be applied to the development of countermeasures in the fight against propagandistic troll armies. These are only the primary ideas that have to be worked out in further in detail using TRIZ tools in order to develop the appropriate anti-trolling strategy.

References

1. Bercean, I. "Ukraine: Russias new art of war", On-line Journal „Modelling the New Europe“, Issue no. 21/2016, pp. 156-174, ISSN: 2247-0514, available: <http://neweurope.centre.ubbcluj.ro/wp-content/uploads/2012/05/Online-journal-No.-21-December-2016.pdf> [accessed 2019-03-20].
2. Rouse M. cyberwarfare [online], updated 2017-09, available: <https://searchsecurity.techtarget.com/definition/cyberwarfare>, [accessed 2019-03-20].
3. Reuter M. „Fake-News, Bots und Sockenpuppen – eine Begriffsklärung“, [Fake news, bots, and sock puppets – a disambiguation, online], available: <https://netzpolitik.org/2016/fakenews-social-bots-sockenpuppen-begriffsklaerung/> updated 2016-11-29, [accessed 2019-03-20].
4. Sasse D. „Internet-Trolle sind verkappte Sadisten“, [Internet trolls are disguised sadists, online] Gesellschaft Internet Psychologie, Wissenschaft aktuell & Scientec Internet Applications Media GmbH, available: http://www.wissenschaft-aktuell.de/artikel/Internet_Trolle_sind_verkappte_Sadisten_1771015589505.html, updated 2014-02-28, [accessed 2019-03-20].
5. Glueck A. „Handbuch für den Forentroll“, [Handbook for trolling], Röhrig Universitätsverlag GmbH, St. Ingbert, 2013, 135 S., ISBN: 978-3-86110-535-0
6. Bradshaw S., Howard P. "Troops, Trolls and Troublemakers: A Global Inventory of Organized Social Media Manipulation", [online], University of Oxford, Computational Propaganda Research Project, Working paper no. 2017.12. available: <https://t.co/iRfvoNEDeW>, updated 2017-07-17, [accessed 2019-03-20]
7. Farrell H. "The Chinese government fakes nearly 450 million social media comments a year. This is why", The Washington Post, 2016-05-19. available: <https://www.washing->

- tonpost.com/news/monkey-cage/wp/2016/05/19/the-chinese-government-fakes-nearly-450-million-social-media-comments-a-year-this-is-why/?utm_term=.02574b67fb66, [accessed 2019-03-20].
8. Bendiek A. „Das neue „Europa der Sicherheit“ Elemente für ein europäisches Weißbuch zur Sicherheit und Verteidigung“. Stiftung Wissenschaft und Politik, Deutsches Institut f. Internationale Politik und Sicherheit, 2017, SWP Aktuell 37; ISSN 1611-6364
 9. Proactive cyber defence [online] available: https://en.wikipedia.org/wiki/Proactive_cyber_defence, updated 2017-06-30, [accessed 2018-07-05].
 10. European Parliament “Joint Framework on countering hybrid threats a European Union response” Brüssel, 6.4.2016, JOIN(2016) 18 final, available: <https://eur-lex.europa.eu/legal-content/EN/TXT/?uri=CELEX:52016JC0018>, [accessed 2018-07-10].
 11. European Parliament “Report: EU strategic communication to counteract propaganda against it by third parties” A8-0290/2016, 14.10.2016, available: http://www.europarl.europa.eu/doceo/document/A-8-2016-0290_EN.pdf, [accessed 2018-07-10].
 12. European Commission „White paper on the future of Europe”, Brussels, 2017, available: <https://publications.europa.eu/en/publication-detail/-/publication/ba81f70e-2b10-11e7-9412-01aa75ed71a1>, [accessed 2019-03-20].
 13. Perspective “What if technology could help improve conversations online?” 2017, available: <https://www.perspectiveapi.com/#/>, [accessed 2019-03-20].
 14. Tantiverdi H. „Google will Trolle mit künstlicher Intelligenz bekämpfen“ [Google will fight trolls with artificial intelligence, online]. Sueddeutsche.deDigital, 23. 02. 2017, available: <http://www.sueddeutsche.de/digital/online-kommentare-google-will-trolle-mit-kuenstlicher-intelligenz-bekaempfen-1.3391804>, updated 2017-02-23 [accessed 2019-03-20].
 15. The Computational Propaganda Research Project, Oxford Internet Institute, University of Oxford. 2017, Available:<http://comprop.oii.ox.ac.uk/project-description/>, [accessed 2019-03-20].
 16. VDI Standard 4521 Part 1: Inventive problem solving with TRIZ. Fundamentals, terms and definitions, Berlin: Beuth, 2016-04, available: <https://www.beuth.de/en/technical-rule/vdi-4521-blatt-1/251068736>, [accessed 2019-03-20].
 17. VDI Standard 4521 Part 3: Inventive problem solving with TRIZ. Problem solution, Berlin: Beuth, 2019 [to be published]
 18. Mann D L. Matrix 2010. Re-updating the TRIZ contradiction matrix. Clevedon: IFR Press, 2009. ISBN 978-1-906769-19-2.

Communication

Communicating Author: Nadiya.Hiltmann@stud.hs-coburg.de

TRIZfest 2019

September 11-14, 2019. Heilbronn, Germany

APPLYING OF HYBRIDIZATION FOR DEVELOPMENT OF FLEXIBLE DISPLAY DEVICE

(CASE STUDY IS BASED ON US984193, EP3306439 AND USD819630)

Valeriy Prushinskiy

Samsung Electronics, Suwon, 16677, South Korea

Paper Classification:

- Best practices, business experiences, integration with non-TRIZ methods/tools
- Case study

Abstract

Electronic devices with flexible displays are next generation of mobile devices that should provide compact form factor for convenient single-hand use or placement in front pocket, wearable form factor for utilization on-the-go and stand-up form factor and tablet form factor for in-office or at-home use. Concept of four-in-one hybrid device described in patents US984193, EP3306439 AND USD819630 was developed by applying multi-step hybridization process.

Keywords: *multi-step hybridization, flexible display device, transformable electronic devices*

1 Project

Electronic devices, such as smartphones, tablet PCs, and the like, may output contents, for example, images, text, and the like through displays thereof. Electronic devices having various forms of displays have been released, and in recent years, electronic devices equipped with flexible displays have been developed.

Electronic devices having flexible displays may provide efficiencies in space utilization since the displays are foldable or bendable. Electronic devices having flexible displays may be thin and lightweight, and the displays may not be easily broken or damaged.

Flexible displays may be applied to various fields, such as wearable devices, automotive displays, tablet devices, and the like, as well as smartphones. Development of all in one device, combining advantages of these devices while providing convenient interface is required.

2 TRIZ relation

Algorithm of consecutive hybridization allows crossing of as many systems as needed for obtaining new promising concepts, combining advantages of these systems and eliminating their

disadvantages [1,2,3]. Also, the algorithm helps in process of combining of different types of engineering systems (including alternatives systems and non-alternatives systems). Author applied the algorithm both for development of concept of new products and new manufacturing technologies [4]. Here is brief description of the algorithm steps:

1. Identify initial engineering system (describe as a set of simple ideas with list of advantages and disadvantages)
2. Describe candidate for crossing (describe as a set of simple ideas with list of advantages and disadvantages)
3. Describe hybridization contradiction
4. Select dominant engineering system
5. Reveal resources for hybridization
6. Describe portrait of hybrid
7. Formulate ideal vision of hybridization problem
8. Reveal resources of dominant engineering system
9. Describe intermediate hybrid
10. Reveal drawbacks, not addressed by intermediate hybrid
11. Select next engineering system for hybridization
12. Repeat hybridization process for selected engineering system and intermediate hybrid (The process is repeated for multiple systems in multiple iterations as needed)

Since consecutive hybridization process consists of multiple iterations of crossing different systems, it will be explained below based on concepts described in patents US984193, EP3306439 AND USD819630.

Before transition to foldable devices with flexible displays, designers tried to resolve contradiction “display device has to be small in pocket state and device has to be large in unfold state” by designing two-bodies, two displays rigid foldable devices. Some concepts envisioned even triple-body, so that large size of display can be achieved in open state [8]. Advantage of these system is that they can be folded into compact “pocket size” form factor, disadvantage is too much of space between displays and double or triple thickness in compact state, in comparison with compact single-body devices.

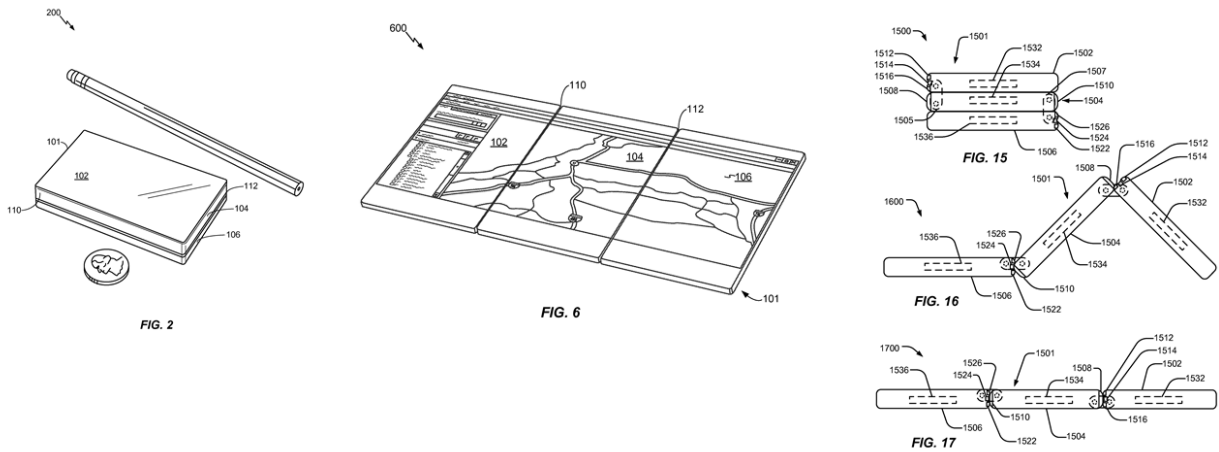


Fig. 1. Multi-body foldable device with rigid displays

At the beginning of the project, most of the efforts were focused on devices with flexible display, folding-in-half. Advantage of these systems is compact “pocket” form factor for “on-the-go” mode, and opening into tablet for “at-home” or “in-office” use. There were two initial approaches: fold-in and fold-out systems. Disadvantage of fold-in system is too small radius of bending, that can cause faster deterioration of display [9]. Fold-out systems can provide bigger radius of bending of display, but require special hinge system, preventing stretching of display. Both fold-in and fold-out systems envisioned folding-in-half, so that thickness of device in fold state is doubled, causing inconvenience for consumers.

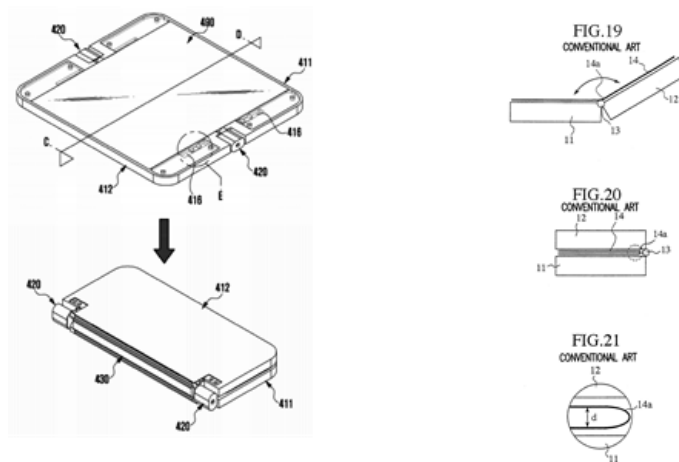


Fig. 2. “Fold-in” foldable electronic device

1st iteration of hybridization

1. Identify initial engineering system (describe as a set of simple ideas with list of advantages and disadvantages)

“Fold-out” system is selected as initial system due to its advantage - greater radius of bending (roughly calculated, if there is folded-in-half device, its thickness is equal to thickness of two devices, so it makes around $8+8=16$ mm if thickness of current generation of devices is taken 8 mm. This way, fold-out radius is around 4 mm). At the same

time, its disadvantage is double thickness of the body, worsening its consumer properties.

2. Describe candidate for crossing (describe as a set of simple ideas with list of advantages and disadvantages)

Single-body device with wrap around display. Advantage: Single body thickness; wrap-around display is “container” for internal parts of electronic device; radius of bending of wrap-around display is large enough, so that display is not easily disintegrated along the bending line. Disadvantage: since display is fixed, back part of display is invisible from the front.

3. Describe hybridization contradiction

Hybrid device has to has fold-out design so that display would not be disintegrated and delaminated along the bending line, and the hybrid device has to has single device thickness, so that consumer requirements will be satisfied.

4. Select dominant engineering system

Single body display device is selected as dominant system.

5. Reveal resources for hybridization

Single body fold out display device.

6. Describe portrait of hybrid

Hybrid device has to has single body and flexible display around it

7. Formulate ideal vision of hybridization problem

Hybrid device without any complications provides “doubled” display area.

8. Reveal resources of dominant engineering system

Flexible display with bending equal to radius of half of single body.

9. Describe intermediate hybrid

Hybrid single-body device with display, partially fixed along the front part of device, and not fixed to it at remained part, capable to bend around device for “pocket” mode and unfold to open display surface. Advantages: single body thickness, radius display is large enough to reduce stress.

The device can be realized two variants:

Variant 1: Electronic device with display, fixed to rigid body and having flexible display extended form one side of the body (“single-wing” system).

Variant 2: Electronic device with display, fixed to rigid body in the middle part and having two parts of flexible display extending from two sides of the body (“double-wing” system). “Double-wing” system is selected, because support of shorter wings can be easier addressed.

10. Reveal drawbacks, not addressed by intermediate hybrid

Not fixed part of display is not supported in unfold state. Secondary problem is how to support “not-fixed” flexible part of display.

11. Select next engineering system for hybridization

“Fold-in” display system.

2nd iteration of hybridization

1. Identify initial engineering system (describe as a set of simple ideas with list of advantages and disadvantages)

“Double-wing” electronic device with display, fixed to rigid body in the middle part and having two parts of flexible display extending from two sides of the body. Advantage of “double-wing” system is large display in open state, disadvantage is not supported surface of the tips of the wings.

2. Describe candidate for crossing (describe as a set of simple ideas with list of advantages and disadvantages)

“Fold-in” device has continuous and uniform support of display, but its disadvantage is too small radius of bending of display.

3. Describe hybridization contradiction

Hybrid device has to be as “double-wing” system in compact state to provide portability and has to be as “fold-in” system, to provide uniform support to the flexible part of display.

4. Select dominant engineering system

“Double-wing” display device is selected as dominant system.

5. Reveal resources for hybridization

Uniform support of display of “fold-in” device.

6. Describe portrait of hybrid

Hybrid device has to have two bodies and “double-wing” flexible display.

7. Formulate ideal vision of hybridization problem

Hybrid device without any complications provides uniform support of “double-wing” display area.

8. Reveal resources of dominant engineering system

Body of device supports display.

9. Describe intermediate hybrid

Hybrid device can have split body, with display fixed in area of rigid body and free hanging flexible display between rigid parts.

Advantages:

- *Single body thickness*
- *Bending around the body prevents fast disintegration of display in bending area*
- *Large display in unfold state*

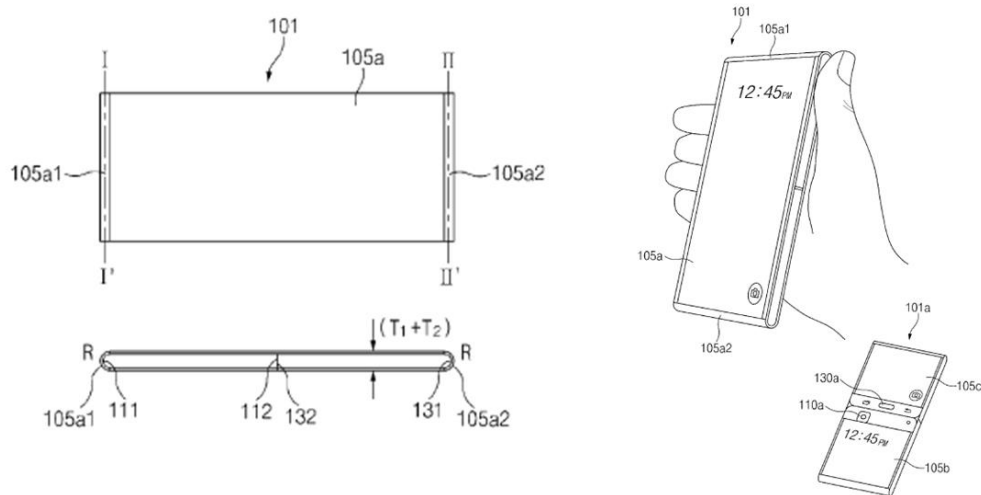


Fig. 3. “Split-body” foldable electronic device in closed state

10. Reveal drawbacks, not addressed by intermediate hybrid

Disadvantages of intermediate hybrid

- *Flexible middle part is not supported*
- *Body parts are not connected in fold state*

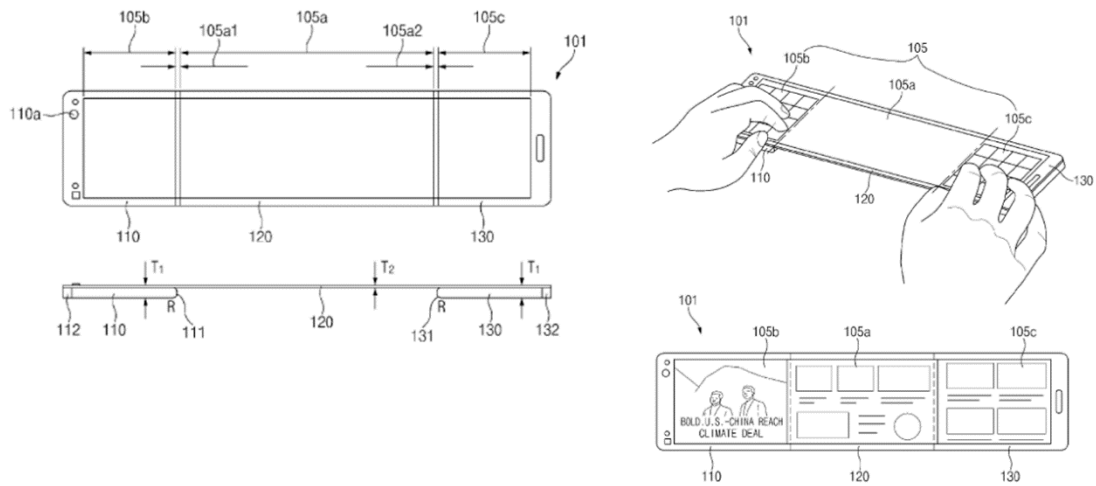


Fig. 4. “Split-body” foldable electronic device in open state

11. Select next engineering system for hybridization

Smart cover, connectable to tablet-devices by magnets. For this, tablet is designed with magnets installed inside the body of device.

3rd iteration of hybridization

Intermediate hybrid is crossed with cover with functional magnets. Due to limitations of size of the article, full description of the steps is omitted.

As result of this iteration of hybridization, concept of electronic device with split body, connectable by magnets C1 and C2 (Fig.5) installed locally was developed.

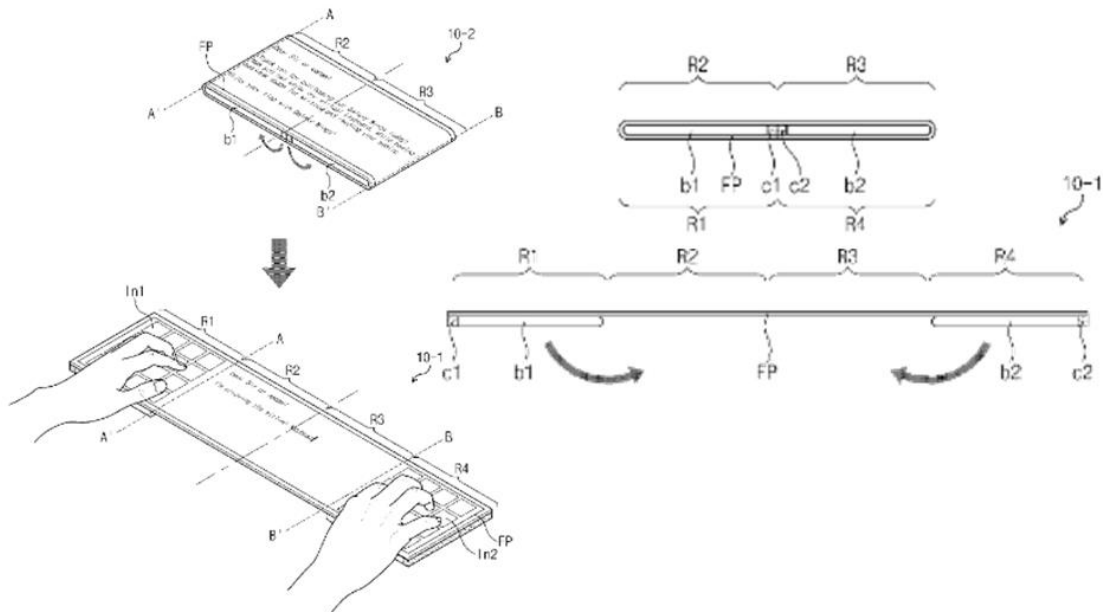


Fig. 5. “Split-body” foldable electronic device with magnet-connectors

4th iteration

During this iteration of hybridization, previous intermediate hybrid device with split body and magnetic connectors is crossed with smart watch device.

Advantage of regular smart watch device is ability to have “wearable” form factor, when device is worn around user’s hand. Disadvantage of this device is too small display of device.

Advantage of split body device with magnetic connectors is “pocket” size in fold state and large display in unfold state. Disadvantage of this device is absence of wearable form factor.

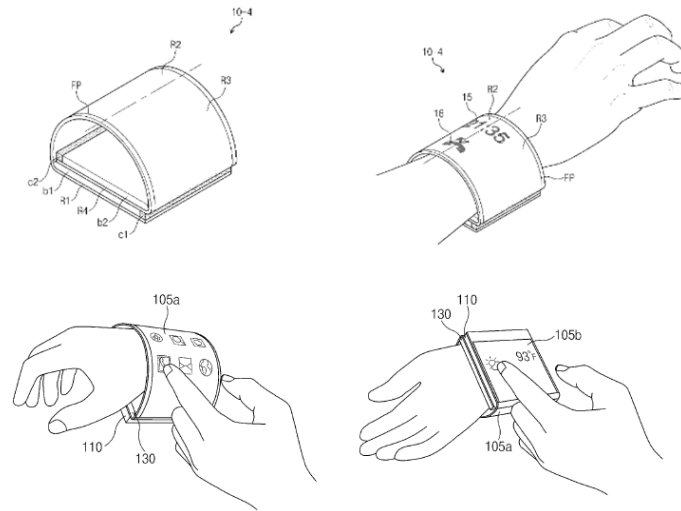


Fig. 6. Wearable state of “Split-body” foldable electronic device

As result of this iteration of hybridization, concept of wearable display device that worn around user’s hand while being held in connected state by magnets (Fig.6).

Another disadvantage that was revealed is absence of “stand-up” factor for office and home. Based on idea of “connect-ability” by magnets following form factor was proposed (Fig.7).

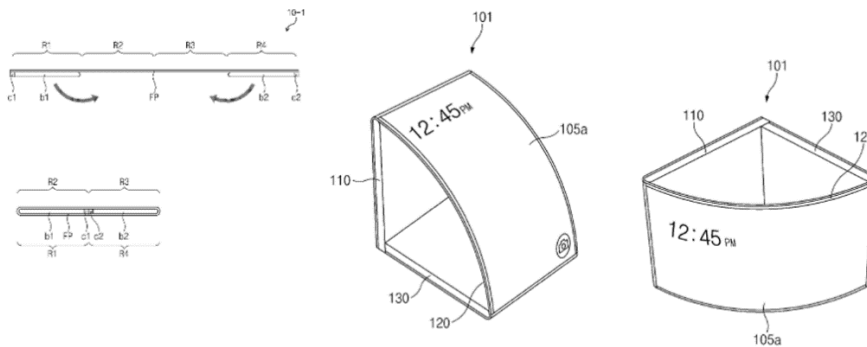


Fig. 7. Stand-up state of “Split-body” foldable electronic device

5th iteration of hybridization

Currently, smartphones are often utilized in car for navigation purposes.

During this iteration of hybridization, concept of utilization of proposed foldable display device for navigation in car was developed. For these purposes, special supports 610 with magnets that

can attract and hold the device with split body in unfold state can be installed in the car in front of the driver (Fig.8).

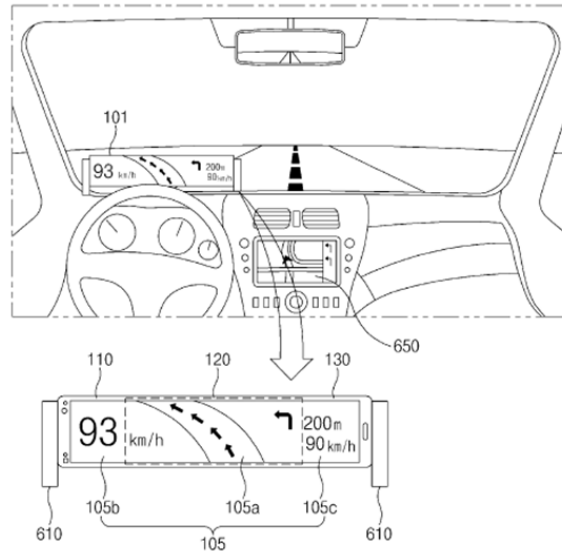


Fig. 8. Utilization of “Split-body” foldable electronic device in car for navigation

Additionally, it was proposed to have semi-transparent display in the middle part, so that driver can see-through the display and have AR (Augmented Reality) road information on line-of-site.

6th iteration of hybridization

Proposed concept of the device has unusually long display. This display is long and narrow, so that the device can be hardly utilized as tablet.

In order to address this disadvantage, it is proposed to cross the device with tablet. Advantage of the tablet is large display area for browsing and emailing, but absence of “pocket” form factor.

As a result of this iteration of hybridization, concept of wider, tablet-like device with split body was proposed. In order to support flexible device in the middle part, it was proposed to add narrow support rib in the middle part under display.

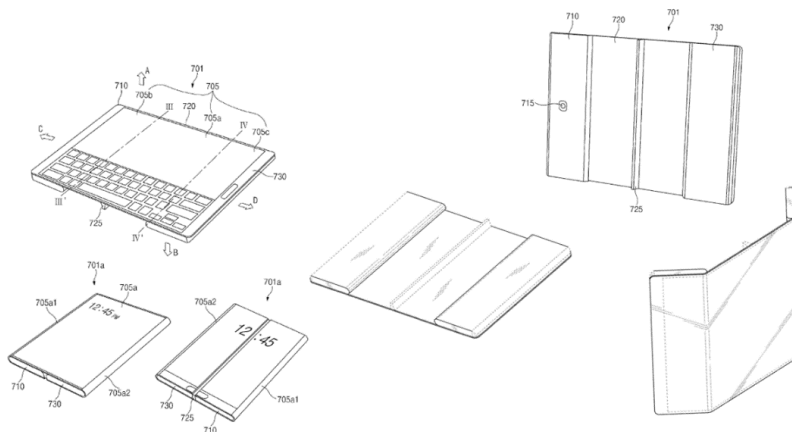


Fig. 9. Tablet form factor of “Split-body” foldable electronic device

3 Results

Concept of four-in one hybrid device was developed by applying of multi-step hybridization approach. The concept was protected by patents US984193, EP3306439 AND USD819630 and prototyped.

4 Conclusions

Proposed electronic device provides to customers compact form factor for convenient single-hand use or placement in front pocket, wearable form factor for utilization in on-the-go and stand-up and tablet form factor for in-office or at-home use, while reducing overall thickness of the device. Usability and attractiveness of flexible device for potential customers was significantly improved by applying hybridization. The concept described in the patents was appreciated by leading digital publishers [9, 10].

References

1. Val Prushinskiy, Gafur Zainiev, Vladimir Gerasimov. HYBRIDIZATION, The New Warfare in the Battle for the Market. ISBN 1-59872-069-4
2. Valeriy Prushinskiy. ALGORITHM OF CONSECUTIVE HYBRIDIZATION OF PRODUCTS AND HYBRIDIZATION SCHEMES. Author's Abstract of thesis for the Master's Degree in TRIZ. Procedures of 2011 MATRIZ Dissertation Council. Source: <http://triz-summit.ru/file.php/id/f4997/name/autoreferat%20-%20vprushinskiy%20eng%20v22062011.pdf>
3. Валерий Прушинский. «Изобретать может каждый». Москва, Издательство Форум, 2012.с. 124-131 (Valeriy Prushinskiy. «Everyone can Invent». Moscow, Forum Publishers, 2012. p.124-131.
4. Valeriy Prushinskiy, MinSoo Kim. Applying Consecutive Hybridization Approach for Mask Manufacturing (Case study is based on US 20130071775 A1). Proceeds of TRIZfest 2014, Prague, 2014.
5. US984193 Foldable display
6. EP3306439 Electronic device having flexible display
7. USD819630 Electronic device
8. US 20110216064 Electronic device
9. US 9557771 Electronic device including flexible display
10. Forbes. Is this first look at Samsung's folding Galaxy Note 10? (March 27, 2019) <https://www.forbes.com/sites/ewanspence/2019/03/27/new-samsung-galaxy-note-10-fold-rumor-leak-concept-image-picture/#470b952332c0>
11. Digital Trends. Samsung may already planning a completely different foldable device. <https://www.digitaltrends.com/mobile/samsung-foldable-tablet-news/>

Communication

Communicating Author: valrush@hotmail.com

TRIZfest 2019

September 11-14, 2019. Heilbronn, Germany

BIG DATA ANALYSIS: A RESOURCE TO BE CONSIDERED IN TRIZ

Oliver Mayer^a, Tiziana Bertoncelli^b

^a*Bayern Innovativ, Nürnberg, Germany*

^b*Danfoss Silicon Power, Ismaning, Germany*

Paper Classification:

- Theoretical, research results

Abstract

Fields and Resources are a key element to be considered in TRIZ, since their analysis and systematic consideration opens new opportunities for solving problems, especially during the initial stages of the innovation process. In ARIZ Resource Analysis is an integral part of the process for problem solving. The original MATChEM acronym was introduced by Altshuller to serve as a checklist for consideration of substances and fields as resources. Iouri Belski expanded the list with Intermolecular and Biological items to MATChEM-IB. This paper suggests adding Big Data Analysis (thus capturing at once Big Data and the knowledge gained by the analysis thereof) as an additional field in the updated list: MATChEMIB²DA

Keywords: *Resources, Big Data, Data Analysis, MATChEM, MATChEM-IB*

1 Field and Resources in TRIZ

1.1 TRIZ Theory State-of-the-Art

TRIZ provides several procedures to solve problems [1]. Originally the focus laid on technical systems, and products, handling of contradictions and Trends of Engineering System Evolution (TESE). With TESE and the formulated trend that systems merge with super-system elements, it became obvious that elements in the super-system can be taken as resources to solve problems. Altshuller standardized this procedure and implemented Resource Analysis as an important tool in ARIZ. Under section 2.3 of the ARIZ Algorithm Resources are explicitly included. For the system all the available Resources (Substances and Fields) are addressed, including their parameters. Helpful resources are looked for in the:

- Environment in the operating space
- Specific environment for the problem
- General ambient resources
- Super-system
- Wastes, by-product, secondary resources

In step 3.3 of ARIZ it is systematically analyzed how resources (and their parameters) could be employed to solve the problem.

Therefore, Resources represent not only a very powerful analytical tool, but are essential to solve problems formulated with the other TRIZ tools belonging to both the Problem Analysis and Solving Stages, i.e. Technical Contradictions, Physical Contradictions, Standard Solutions and Adaptation approaches.

Resources in TRIZ are defined as:

- Any substance, field, and/or their parameters (including time and space) available in the system or its environment
- Whatever has the functional and technological ability to jointly perform additional functions

This is a very generic definition. The application of this approach in case of substances is straightforward: for every piece of material available in the environment the generalized inventive question:

“How can <substance> help solve the problem?”

can be formulated.

The case of fields deserves a deeper effort, since fields in TRIZ definition are not strictly physical fields. In Physics only four fields exist:

- Gravitation
- Strong field (quarks-interaction)
- Weak field (β -interaction)
- Electro-Magnetic field

In TRIZ practice the field term, apart from the analogy from physical fields, has no strong formal definition; in fact, is used in a similar way as in technical branches, e.g. as electric field, temperature field, force field or velocity field, as well as in mathematics, e.g. as probability field. According to the transformation properties of the field quantities compared to orthogonal transformations, a distinction is made between scalar fields (e.g. temperature or mass density), vector fields (e.g. force, flow velocity, electric field or magnetic field strength and tensor fields, mechanical stress of an elastically deformed body or deformation).

Scalar fields are seen in TRIZ as parameters usually of an overlaying vector / electro-magnetic or tensor field. Stationary fields have time-independent field sizes and describe stationary states of motion, e.g. a stationary fluid flow. A field is called quasi-stationary if the retardation can be neglected. A field is homogeneous if the field size assumes the same value at every point in the room, otherwise it is inhomogeneous. Homogeneous fields are, for example, the electric field constant in magnitude and direction inside a (infinitely extended) plate capacitor and (in good approximation) the gravitational field of the earth near the earth's surface (gravity).

Many of the fields occurring in technical branches are abstractions with which systems consisting of many individual particles, such as gas or liquid molecules or the individual stars of a galaxy, can be reduced to a few degrees of freedom. In contrast, the physical electromagnetic and gravitational fields describe manifestations of matter and space that cannot be further reduced. In quantum field theory, these fields are considered to be composed of (an unimaginable number of) individual field quanta (field operator), but these in turn belong to the fundamental

elementary particles that cannot be further explained. Originally the physical fields were introduced around 1840 by M. Faraday as auxiliary quantities. Only the theory of the electromagnetic field developed by J.C. Maxwell (1856) and the experimental confirmation of the electromagnetic waves predicted by this theory by H. Hertz (1887) led to the realization that the fields themselves possess physical reality (near effect theory).

This strict definition of Fields [2] is very abstract and of limited use in practise; to get this closer to everyday experience and more practically applicable by practitioners a checklist was developed for technical fields: the MATChEM list, shown in the blue part of Fig. 1 (lighter shaded).

This list comprises 6 key technical fields

- Mechanical
- Acoustic
- Thermal
- CHEmical
- Electro
- Magnetic

In Fig. 1, columns 2 and 3 examples on interactions that these field evoke and opposite parameters (scalar fields) are given.

1.2 MATChEM Expansion to MATChEM-IB:

In [3] Belski researched Fields and Resources further and updated the table based on novel insight, adding two new fields:

- Intermolecular
- Biological

Where the biological field refers to the collective effect exerted by an assembly of living organisms, like bacteria, not observable as distinct entities with respect to the dimensions of the system under investigation. The checklist acronym was thus updated to MATChEM-IB. This expansion was needed in the light of novel research and advancements in technology that made new resources available. TRIZ powerfulness is also based on its continuous adaption to novel technological developments. Nowadays many emerging fields, like Artificial Intelligence (AI), AI combined with medicine, energy informatics, energy internet, Internet of Thing (IoT)s, rely on data: therefore, recognizing the recent technology development, this paper suggest to expand the checklist further, introducing a new field: Big Data Analysis, underlying both the availability of an unprecedented database of information and the set of data processing tools that allow the extraction of information and structured knowledge. In Modern TRIZ Theory, data is only referred to as information and formally considered at the stage of Flow Analysis as one of the three possible flows: energy (field), mass (object), and information, and no further definition is given. The need to include Big Data and Data Analysis in the formal theory in view of the recent studies will be extensively discussed.

Fields	Some Interactions and Substances	Some Opposite Characteristics
Mechanical	Gravitation, collisions, friction, direct contact, vibration, resonance, shocks, waves, gas/fluid dynamics, wind, compression, vacuum, mechanical treatment and processing, deformation, mixing, additives, explosion.	Heavy - Light; Quick - Slow; Hard - Soft; Strong - Weak; Tall - Short; Pressurised - Vacuumed; Viscous - Watery; Compressed - Expanded; Composite - Uniform; Sharp - Blunt; Laminar - Turbulent; Floating - Sinking; 1D - 2D - 3D; Stiff - Flexible; Solid - Liquid - Gaseous; Constant - Pulsed - Periodic; Mobile - Stationary; Accelerating - Decelerating.
Acoustic	Sound, ultrasound, infrasound, cavitation.	Loud - Quiet; Constant - Pulsed - Periodic.
Thermal	Heating, cooling, insulation, thermal expansion, phase/state change, endo- / exo-thermic reactions, fire, burning, heat radiation, convection.	Hot - Cold; Endo-thermic - Exo-thermic; Solid - Liquid - Gaseous; Fire-resistant - Flammable; Conducting - Insulating.
Chemical	Reactions, reactants, elements, compounds, catalyst, inhibitors, indicators (pH), dissolving, crystallisation, polymerisation, odour, taste, change in colour, pH.	Reactive - Neutral; Colourful - Colourless; Strong - Weak; Translucent - Opaque; Absorptive - Non-absorptive; Soluble - Insoluble; Homogeneous - Heterogeneous; Hydrophobic - Hydrophilic; Volatile - Stable; Solid - Liquid - Gaseous; Poisonous - Nutritious; Smelly - Odourless; Tasteless - Wet - Dry.
Electric	Electrostatic charges, conductors, insulators, electric field, electric current, superconductivity, electrolysis, piezo-electrics, ionisation, electrical discharge, sparks.	Charged - Uncharged; Conducting - Insulating; AC - DC.
Magnetic	Magnetic field, forces and particles, induction, electro-magnetic waves (X-ray, microwaves, etc.), optics, vision, colour / translucence change, image.	Magnetic - Non-Magnetic; Translucent - Opaque; Colourful - Colourless; visible - Invisible.
Intermolecular	Subatomic (nano) particles, capillary, pores, nuclear reactions, radiation, fusion, emission, laser, intermolecular interaction, surface effects, evaporation.	Porous - Solid; Permeable - Impermeable; Radioactive - Non ionising; Stable - Unstable,
Biological	Microbes, bacteria, living organisms, plants, fungi, cells, enzymes.	Heavy - Light; Quick - Slow; Hard - Soft; Tall - Short; Poisonous - Nutritious; Sensitive - Insensitive.

Fig. 1: Expanded MATCHEM-IB Table

2. Data and Big Data Analysis as a Resource in TRIZ

Resources shall help to solve technical problems. The fundamental idea of the checklist MATCHEM-IB is to point the inventor in a certain direction of thinking and to open new idea spaces before hidden to him.

Nowadays many emerging fields, like Artificial Intelligence (AI), AI combined with medicine, energy informatics, energy internet rely on data. AI itself can be seen as an assembly of software codes, that allow a machine to take decisions and perform functions in an autonomous manner, imitating human intelligence [4a-4b]. With rising IT power (Information Technology) and AI capabilities, computers today can find hidden pattern in large amount of data (Big Data Analysis). These hidden patterns help to find solutions where nobody else has seen them before.

As a popular example traffic prediction for traffic jams can be seen: by analyzing the movement of cellular phones in the countryside, hopping from one transmission post to the next and correlating this with time give you an information of the speed of movement along a highway. When recognizing that the speed is deviating from the speed the cell phones would jump at no traffic, traffic jams can be predicted. Other examples are identification of customers' habit and preferences for tailored advertising of consumer products and image recognition: Data are the resource that allowed the development of Deep Learning [5].

Also TRIZ itself is a result of a sort of ahead-of-the-times Big Data Analysis. Altshuller evaluated more than 200,000 patents by hand (not automated as the technology was not available at that time) and detected patterns: First he separated "breakthrough" patents with high inventive level. Out of these remaining 40,000 patents he derived the 40 IP (Inventive Principles) and the TESE (Trends of Engineering System Evolution). Altshuller himself used the BDA (Big Data Analysis) as a source to generate the knowledgebase that allowed him to formulate the TRIZ solutions for solving system engineering problems.

The discussion about TRIZ and data comprises various aspects covered in several conference contributions addressing TRIZ and software, digitalization, Internet of Things (IoT); moreover, the need to consider Big Data and Data Analysis in TRIZ practice already emerged in several contributions.

In [6] the joint application of TRIZ Big Data, patent analysis and statistical data is introduced for all the cases where Innovation needs not to emerge as solution of a problem-solving process, but rather as an idea allowing the inventor to be the first mover of the market, discovering an unknown problem or a hidden need/wish of the customer.

Litvin and Prokofiev [7] stated that the link between TRIZ Theory and Internet of Things (and Information Technology in general) exists and it is the Function Approach; they reinforced their thesis presenting several examples and proposing a general function model of an IoT system, where element like:

- Database
- Social network
- Events
- Interface

are components. Components, according to the definition, could be Substances (with rest mass), Fields and/or combinations thereof. During TRIZfest2018 Data (along with Social Data, meaning Data extracted from social networks) were pointed as source of inspiration both during the Keynote by Samsung Electronics [8], where Data Analysis is considered a source of key insights, and where the need to expand the list of Resources is highlighted as one of the needed directions for the future development of TRIZ:

“Development is needed in terms of successes in sensors and new application fields. In particular, data (data analytics) in the field of cloud computing, artificial intelligence, and deep learning are upcoming resources that must be covered in the future. Ecosystems are part of the super-system, and, relevant ecosystems should be visible as resources (e.g., digital platforms from Microsoft Azure and Amazon AWS or opensource assets on the market).”

These observations capture the general direction and still are not affected by the nature of Data, neither cover a formal definition beyond listing Data and all related analysis tools as a Resource (Substance, Field, Parameter). In [10] an extensive discussion is given about TRIZ and Digitalization: Big Data is defined as a Resource and it is also stated that *“Information is always represented as a field”*, but not seen as a Field itself.

In this view collections of data can be regarded as collection of parameters and immaterial resources. In TRIZ Parameters, Field and Substances are clearly distinguished and represented differently in a Function Model. A temperature or electric potential field represent a spatial distribution of parameters describing an energy state; magnetic and electromagnetic fields represent a status distributed in space and described by field values, and in TRIZ thinking they are able to cause an action on other components. So are Big Data a Resource, a Parameter or a Field?

While the MATChEM-IB fields can be described as “entities represented by a measurable effect”, Data can be described as a source of structured information; Data Mining Techniques are aimed to improve the level knowledge and awareness about the System; Data quantitative measurement (i.e. in Terabyte) however is not a quantification of the level of knowledge that can be extracted. So to express the value added by a given set of Data, the knowledge extraction methodologies should be added.

In order to classify Data as a field, Data should be able to exert an action on components. There is no formal list of requirements for fields to be defined as such. Nevertheless, the following observations can be listed:

- Data are an immaterial resource, artificial
- Data support decisions
- Decision is an immaterial action

Big Data and the results of Data Analysis can be described in terms of spatial and temporal distribution of parameters and influence decisions, either taken by humans or automated system, thus exerting an immaterial action.

In this view, Big Data and Big Data Analysis (BDA) can be regarded as a field.

This paper therefore suggests expanding the MATChEM-IB checklist to MATChEM-IB²DA as shown in Fig. 2.

Fields	Some Interactions and Substances	Some Opposite Characteristics
Mechanical	Gravitation, collisions, friction, direct contact, vibration, resonance, shocks, waves, gas/fluid dynamics, wind, compression, vacuum, mechanical treatment and processing, deformation, mixing, additives, explosion.	Heavy - Light; Quick - Slow; Hard - Soft; Strong - Weak; Tall - Short; Pressurised - Vacuumed; Viscous - Watery; Compressed - Expanded; Composite - Uniform; Sharp - Blunt; Laminar-Turbulent; Floating - Sinking; 1D - 2D - 3D; Stiff - Flexible; Solid - Liquid - Gaseous; Constant - Pulsed - Periodic; Mobile - Stationary; Accelerating - Decelerating.
Acoustic	Sound, ultrasound, infrasound, cavitation.	Loud - Quiet; Constant - Pulsed - Periodic.
Thermal	Heating, cooling, insulation, thermal expansion, phase/state change, endo- / exo-thermic reactions, fire, burning, heat radiation, convection.	Hot - Cold; Endo-thermic - Exo-thermic; Solid - Liquid - Gaseous; Fire-resistant - Flammable; Conducting - Insulating.
Chemical	Reactions, reactants, elements, compounds, catalyst, inhibitors, indicators (pH), dissolving, crystallisation, polymerisation, odour, taste, change in colour, pH.	Reactive - Neutral; Colourful - Colourless; Strong - Weak; Translucent - Opaque; Absorptive - Non-absorptive; Soluble - Insoluble; Homogeneous - Heterogeneous; Hydrophobic - Hydrophilic; Volatile - Stable; Solid - Liquid - Gaseous; Poisonous - Nutritious; Smelly - Odourless; Tasteless - Wet - Dry.
Electric	Electrostatic charges, conductors, insulators, electric field, electric current, superconductivity, electrolysis, piezo-electrics, ionisation, electrical discharge, sparks.	Charged - Uncharged; Conducting - Insulating; AC - DC.
Magnetic	Magnetic field, forces and particles, induction, electro-magnetic waves (X-ray, microwaves, etc.), optics, vision, colour / translucence change, image.	Magnetic - Non-Magnetic; Translucent - Opaque; Colourful - Colourless; visible - Invisible.
Intermolecular	Subatomic (nano) particles, capillary, pores, nuclear reactions, radiation, fusion, emission, laser, intermolecular interaction, surface effects, evaporation.	Porous - Solid; Permeable - Impermeable; Radioactive - Non ionising; Stable - Unstable,
Biological	Microbes, bacteria, living organisms, plants, fungi, cells, enzymes.	Heavy - Light; Quick - Slow; Hard - Soft; Tall - Short; Poisonous - Nutritious; Sensitive - Insensitive.
Big Data Analysis	Data bases, large number of unstructured data, pictures, sounds, scalar fields	Structured – Unstructured; Pattern - Chaos

Fig. 2: Expanded MATChEM-IB²DA Table

3. Example of Application

Outside Su-Field, MATChEMIB represents the set of Field resources. These resources suggest (1) possible principles of operation that can be deployed in order to improve the situation or (2) (human) forms of energy that can be used for the improvement. These fields are expected to be used for the ‘physical’ problems.

Big Data Analysis (BDA) is a field that acts on data in order to get the required information out of unstructured content or even noise. Thanks to BDA, additional information and knowledge can be generated, building a valuable resource, useful for problem solving.

As an example, we consider the following situation [11]: when hiking in the mountains you can find alpine huts that serve as very simple lodges. You can book such a hut in advance. You then get an access code so you can stay overnight in the hut. The hut itself is not populated.

You are the attendant of such an alpine hut in Bavaria, Germany. This hut has 2 living rooms with an integrated oven with kitchen in one room. On the second floor, there are 2 sleeping rooms. The hut can accommodate in total 20 persons. There is no water in the hut. Outside there is a spring delivering cold water. Hot water can be made on the oven. A toilette is located outside of the hut (squat toilet, without rinse). The hut has a solar off-grid system with battery storage, that enables lighting in the hut and the operation of a 12 V coffee machine.

The problem is that customers book the hut but sometimes it is not possible to verify if the right number of persons is communicated. As there is a fee per person and night you as the attendant risk to lose money (you are always reported less persons, never too much persons).

The challenge is how to control the right number of guests in the hut. Now you could be on the hut every time and count, but this is not convenient. When the solar system was installed, the manufacturer mounted a measurement system to track the operation of the system. As parameter, the system voltage, load current, PV current, battery temperature and the hut inside temperature is measured. Also, for a set of measurements the real number was recorded.

The Su-Field model for the situation looks like follows (Fig. 3):

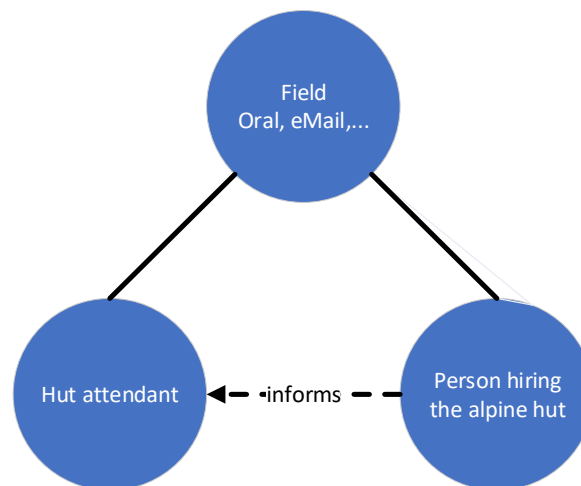


Fig. 3: Su-Field model

We can now apply the Standard Solutions to solve this problem. We can analyze the resources that are available and allocate them to the substances and fields. Using MATHChEM-IB Could lead to solutions like:

- Can we weight the hut (with and without persons in there) to get information on the number of persons?

- Can the hut attendant control the number of persons by checking randomly and physically the hut himself?
- :

The resource “measurement equipment to track the operation of the system” would usually not be considered, because it has no direct relation to the problems; it would probably not even emerge during the analysis/problem identification stage. By adding BDA, this would be different. The question for the field would be: Can we use the data from the measurement system to predict / estimate the number of people in the hut? In [9] BDA analysis was successfully used to find out that it was possible to use the measurement system and to identify what supplementary parameters should be used to raise the accuracy of the prediction.

Other examples where BDA offers unique insights that allow to tackle an unsolvable problem are epidemic expansion of influence and cancer treatment.

The epidemic expansion of influenza can be calculated by BDA of tweets and smart phone messages. It is analyzed where and how many people are communicating about influenza (AIME: Artificial Intelligence and Medical Epidemiology). By this the timely movement and expansion of the illness gets traceable [11].

In pharmacy the application of BDA led to new medication for cancer patients by discovering unknown information in thousands of patient data on cancer, applied medication and the patient's reactions [12].

In fusion reactors, plasma disruption predictions are key to success. This is not possible by using deterministic, physical equations. Only statistical methods and neuronal networks applications are working. And this is Big Data Analysis. The shots at a Tokamak reactor are analyzed and a prediction procedure is calculated. Plasma disruptions can be fatal for a Tokamak (it's about megaampere disappearing in microseconds, which is electromechanically catastrophic. Here we have a very physical problem solved with BDA [13].

With frequent production changes, classically programmed robots lose their economic advantage. Cognitive robotics is supposed to change that. Machines and robots learn by themselves using data-generated algorithms and adapt independently to changes in production. A classic example for the industry is the "reach into the box": In this scenario, baize parts usually lie unstructured on top of each other. They are to be gripped securely and processed further. The challenge for the robot in this task is that for most objects there are no CAD models and only insufficient master data such as size and weight available. The machines therefore must learn by trial and error which gripping technology leads to success [14].

4. Conclusions

This paper suggests incorporating Big Data Analysis (BDA) as an additional field to the MATHChEM-IB list. BDA enables to generate novel insight into data that then can be used to model the system in a way that allows to seek for a solution with additional TRIZ tools. The enrichment of the Field Resources list allows to extend TRIZ applications to many emerging technologies; a more powerful Resource Analysis and Su-Field Analysis can help speed up the problem solving problems, especially in Systems where the problem is represented by an insufficient interaction representing an unsatisfactory communication: the employment of BDA can help finding novel solutions closer to the IFR and in cases it might as well happen that solution

is found without any further TRIZ tool applications (as it can happen as well with other TRIZ tools).

The authors described in this paper an argumentation line to Add BDA to the MATChEM-IB list. Still we are aware that the MATChEM-IB list is dedicated to technical / physical problems. BDA from its DNA is dealing with data and information. The intension is to open a discussion in the community if the expansion of the MATChEM-IB list makes sense, or in view of today's technology developments, it makes sense to think about a similar list for information application.

References

1. GEN3Partners, Professional GEN3 TRIZ Training, 2013.
2. Field Definition Reference, "Basic TRIZ L1", TRIZ-Consulting.de, 2019
3. Belski, I., "Improve Your Thinking: Substance-Field Analysis", TRIZ4You
4. Restelli, M. "#ilPOLIMrisponde - E' vero che l'intelligenza artificiale può diventare pericolosa per l'uomo?", Politecnico di Milano YouTube Channel (in Italian)
<https://www.youtube.com/watch?v=TECgy27zu38>
5. Marr, B. "The Key Definitions of Artificial Intelligence (AI) That Explain Its Importance",
<https://www.forbes.com/sites/bernardmarr/2018/02/14/the-key-definitions-of-artificial-intelligence-ai-that-explain-its-importance/#8fd57a54f5d8>
6. Sejnowsky, T. "The Deep Learning Revolution", The MIT Press, 2018
7. Ji-Young Kima, Hyung-Seok Yeob, Jun-Young Leeb, "Suggestion of Method of Discovering innovative Ideas through Convergence of TRIZ and BIG DATA Solution", TRIZfest 2017 September 16-18, 2017. Krakow, Poland
8. Litvin, S., Prokofiev, A., "TRIZ Approach of Internet of Things", TRIZfest 2018
9. Dr. Dong-Seob Jang, "Value Innovation and TRIZ activities at Samsung Electronics", Opening Keynote, ETRIA TRIZ Future Conference 2018
10. Lynass, M., Schütz, T., Leuner, P., Menzel, M., Wannemacher, P, Mayer, O., Tourbier, D., Zettl, M., Rau, M. "Monitoring of a PV Lighting System in an Alpine Hut", OTTI PV Symposium, Staffelstein, Germany, 2013
11. <https://reset.org/blog/kuenstlicher-intelligenz-die-naechste-epidemie-vorhersagen-06222017>
12. Watson IoT by IBM: <https://www.ibm.com/cognitive/de-de/outthink/quest-with-watson.html>
13. http://www.diee.unica.it/elettrotecnica/materialeSIAS/EAIEE/Seminario_Disruption%20prediction%20AUG%20e%20JET.pdf
14. Fraunhofer IPA – VDI Nachrichten Nr. 13, 29.03.2019

Communicating Author: o.mayer@bayern-innovativ.de

TRIZfest 2019

September 11-14, 2019. Heilbronn, Germany

COMPETENCY-BASED APPROACH IN “EDUCATION WITHOUT LESSON” AT SCHOOL USING THE SYSTEM APPROACH

Gredynarova Elena

Zaporozhye, 69091, Ukraine

Paper Classification:

- TRIZ-Pedagogy

Abstract

Around the world there is a problem of formation and development of student’s soft skills. It is necessary to teach them to act successfully in any uncertain situation. We offer as a solution the introduction of a competence-based education based on the system approach.

Keywords: *TRIZ pedagogy, competency-based approach, universal competencies, competency task, functional system-based approach (FSA), systemic creative thinking.*

1 Project

The study of TRIZ at school, the development of creative and critical thinking skills among students can be essential for the implementation of the idea of a competence approach. During TRIZ lessons, students master the methods and techniques of solving inventive problems, use such concepts as IKR, Contradictions and Resources when solving open problems. Exactly these tools of TRIZ can be used to solve non-standard life tasks.

It is important to note:

- in 2015, an Atlas of Future Professions in Russia was presented,
- In 2016, popular universal skills that need to be developed at school were identified in Davos.
- in 2017, the Ministry of Education of Ukraine took the direction to introduce the competence approach in the program «New Ukrainian School».

This confirms the correctness of chosen approach for the formation of a successful personality.

1.1. We present to your 14 years’ experience in introducing a competence-based approach in teaching students in the EidoS School (Zaporozhye, Ukraine).

EidoS School works since 2001 and has a license of the state sample.

The school works with its own Concept of development and learning of children (Author Gredynarova E. M.), also it introduces TRIZ-pedagogy in all educational process and conducts lessons of TRIZ from 1 to 11 class.

Teachers use a Functional-systemic Approach (FSA, Author Gredynarova E. M.) when they present material on the lesson.

Author's lessons are taught in addition to the General program, such as philosophy, the formation of a successful personality, eidetic, technical creativity, research of physical laws, psychology and training.

You can learn more about the school on the website <http://www.eidos.zp.ua>

1.2. Since 2005, along with other innovative pedagogical technologies, the School has been implementing a competence-based approach.

What caused it?

The results of the 2005 PIRLS and PISA tests at School showed that in the presence of subject knowledge, students do not have the skill of solving life problems, using even the acquired subject knowledge.

There were found the following deficiencies in educational skills:

- unusual form tasks were performed stereotypically, in usual way or were not even executed;
- students didn't attract, where necessary, knowledge of other subjects and their own experience;
- there was the difficulty of translating life situations in the subject, was hard binding of the educational subject and the method of action to the type of task of the educational subject;
- non-standard solutions were rare.

Therefore, it was decided to take a course to implement the tasks that would allow to use subject knowledge in solving every day or non-standard life problems.

Also, in 2005, after participating in the MA TRIZ conference and getting acquainted with the article by Professor O.E. Lebedev, as the basis for the creation of such tasks was taken the idea of competence approach.

1.3. It was important to begin to form student's universal competencies that would allow them to have an algorithm of actions and behavioral skills in any uncertain situation.

At School EidoS, it was taken the following universal competencies as mandatory for the formation:

1. Organizational: the ability to set goals, plan activities in space and time, focusing on the final result; ability to work according to the instructions; find resources to achieve the goal; monitor and evaluate intermediate and final results; perceive each object of the organization as a system in interaction with other systems.
2. Informational: search and ability to use various sources of information; compilation of own information sources; ability to analyze, systematize, compare and critically evaluate information.
3. Communicative: the ability to cooperate in a team; to speak to an audience; ask questions and answer; the ability to prove, argue own point of view; comply with the norms of oral and written speech; speech etiquette; treat communication as a system with a main function and components.

4. Intellectual-logical: the ability to analyze, synthesize, classify material, summarize and draw a conclusion; establish causal relationships and analogies; abstract; apply functional system analysis to any object or phenomenon.
5. Creative: transfer knowledge, the way of activity and existing experience in a new situation; build a hypothesis; set up an experiment; take the survey; if necessary, create new objects or improve existing ones; use TRIZ-tools to go beyond the usual (well-known) systems.
6. Entrepreneurial: take the initiative, generate new ideas; create new products, objects; plan, organize, manage, lead; evaluate and keep records; negotiate; to move easy from independent to collective activity; to risk; motivate others and be motivated and decisive in achieving goals, to see any idea as a system in conjunction with other systems.
7. Criticality: the ability to assess the reliability of information sources; analyze and evaluate arguments and interpretations; identify evaluation criteria; compare and distinguish between ideals and reality; highlight the criteria of similarities and differences; build well-founded conclusions and predictions.
8. Consistency in solving problems, tasks: consider the task (problem) as a system with its super-system and elements of the subsystem, find and use resources, set a goal in the form of IKR, see contradictions and resolve them.

1.4. At the moment, the Competency Approach in education in our understanding is a system of tasks reflecting real life situations and presented in various forms of complex information (text, schedule, table, receipt, schedule, photo), the purpose of which is to form the ability of pupils to act effectively in non-standard situations, applying a set of subject knowledge.

Competence Task is a task, the purpose of which is to form a student's ability to operate effectively in uncertain situations, using a set of subject knowledge.

Knowledge and competencies are not mutually exclusive concepts and are not opposed to each other. Knowledge is within the competence and is its core. Thus, it becomes obvious that the availability of knowledge has not lost its relevance, but in the absence of understanding, application, analysis, synthesis, and evaluation, it is depreciated and is not a competence.

2 TRIZ relation

This concept of Competency Approach, Competence Task and the algorithm for creating Competence Task we considered and developed using the system approach in TRIZ.

There is a paradox of competence in education. It is found outside the subject lessons. Unlike narrow-minded skills, competence manifests itself in solving new problems that have uncertain conditions and require new means and methods of solution that are not given in the subject lessons.

Over the years of practice, we came to the conclusion that the best way to implement the Competence Approach and to get the most efficiency is so cold «education without lesson».

We decided that in our School to build such a system of education is possible. We can create conditions for the formation of competencies and the development of broad competence on the material of school subjects. Of course, for this the ideal would be to go beyond the traditional class-lesson system.

So, we start from «days without lesson», like a project for one day, which integrates various academic disciplines, but educational tasks are not explicit, but immersed in solving the most important task of life. However, this form of education is a rather complicated complex event and this form of work is not yet accessible to everyone, especially in traditional schools, but the «Competence Task» for a separate lesson can be implemented without changing the class-lesson system, only by changing the structure of the lesson that every teacher can.

What was done for this?

An algorithm of creating a Competency Task was developed and polished over 14 years. This algorithm can use by the teacher on a single subject, and can also be used as a basis for creating a lesson-free training or «days without lesson».

The whole teaching staff of the School held seminars and workshops on this topic.

Thus, any of our teachers can, using an algorithm, create a Competency Task for their subject for a new topic of the lesson, to consolidate or deepen the topic and evaluate it. Also, the deputy director of training activities or the methodologist together with the teachers can develop a scenario and spend one or several days of study without lessons.

What is a «day without lessons»?

These are the days when there are no lessons on the schedule, there are only special tasks, fulfilling which students solve life situations and master subject knowledge.

Let us show the organization of the lessons-free day:

- Students form teams. Teams may be of different ages.
- Teams receive tasks.
- Then the teams independently plan the work and perform the competence task to get the result. In the process of implementation students consult with subject teachers.
- At the end of preparing electronic presentations, video clips.
- Teams present their results.

Examples of topics and titles of lessons-free days of project:

- «With Gratitude in the Heart»;
- «Zaporozhye is the best city of Ukraine»;
- «I am the leader of student self-government»;
- «Organization of my leisure»;
- «Day of Ukrainian writing»;
- "Family values";
- «School in a new way: super trends of education»;
- «School of life» Advertising Dimension;
- "How it works: EU (EU project) »;
- «Start-up»;
- «Kraina.ua»;
- «Victory must be prepared»;
- «In the artist's workshop»;
- «The life of wonderful children»;
- «Toy Story»;
- "Patents of nature."

We plan the following topics of competency tasks:

- Advertising project. How to sell not a product, but an emotion, a pleasure from it. Presentation skill. Different types and forms of presentation that may use. Introduction with the basic rules of presentation. Coach teams that help their teams present the product. Invite guests (parents) who have presentation skills.
- Project Pangea. About the split of the continents. As far as visions of fiction coincide, futuristic visions, what will happen? Acquaintance children with the science of forecasting.
- Country Study Project. Consider all sorts of unions, associations, criteria for selection and selection in them. What determines the division of countries into different groups.
- Banking systems project. Financial policy. Communal payments. Credit, deposit. Financial fraud.
- Employment exchange. Self-presentation skills. Set in a team. Teacher from professionals in different groups of professions.
- A programming project. Why this profession is important at this stage and in the future.
- Intellectual curiosity. The ability to learn independently. Basic education and acquaintance with various courses online. The opportunities that surround us in the current free education from the leading universities in the world.
- Art. the ability to analyze objects of art and maintain an intellectual conversation about any picture.
- Ecology of the planet Earth. About global aspects that concern the entire planet. Expand the scope of understanding the problems of other nations and continents.

3 Results

For all the time, the School organized and held more than 500 «days without lessons», introduced with this approach and trained more than 800 teachers from different cities and schools, held more than 50 seminars and lectures on this topic, and more than 10 articles were written.

Students in the process of performing tasks try on various social roles, for example, to be the mayor of the city, the creator of their Start-up, inventor, PR-manager or head of their own travel company. During the project, students independently master all aspects of the proposed topic, linking knowledge of several subjects at once, build their own hypotheses and draw conclusions. Thus, their cognitive initiative and independence develops.

4 Conclusions

The rich experience and results inspired us to create a methodic manual with a detailed explanation of the algorithm for creating such tasks.

We also plan to translate it into English for wide distribution and application.

With great pleasure we will present the Methodical manual at the MATRIZ conference next year.

Using this manual, teachers will be able to:

1. Create life situations with educational tasks hidden in them for a particular academic discipline.

2. To create tasks for the formation of universal competences and the application of subject knowledge of students.
3. To provide student's motivation to search for new tools and ways to solve problems, without giving them in finished form.
4. To form a steady interest in acquiring new competencies in order to expand the range of opportunities and competitiveness.
5. To form system thinking, openness to everything new and stress resistance in a situation of uncertainty.

As experience shows, pupils who do Competence Tasks in the system easily adapt when changing educational and practical activities become more resistant to stressful (uncertain) situations; they have increased motivation for cognitive activity, provided a steady interest in the process of cognition.

Our experience can be useful both for teachers and for parents, because the competence task can be offered to a child outside school at the home or non-school system of interaction.

Now we want to offer you an example of one of these tasks.

Competency work «Travel to the dream»



On one of the central television channels of Ukraine, you saw a video clip <https://www.youtube.com/watch?v=DmbVmKm6WFg> and got a desire to attend this event.

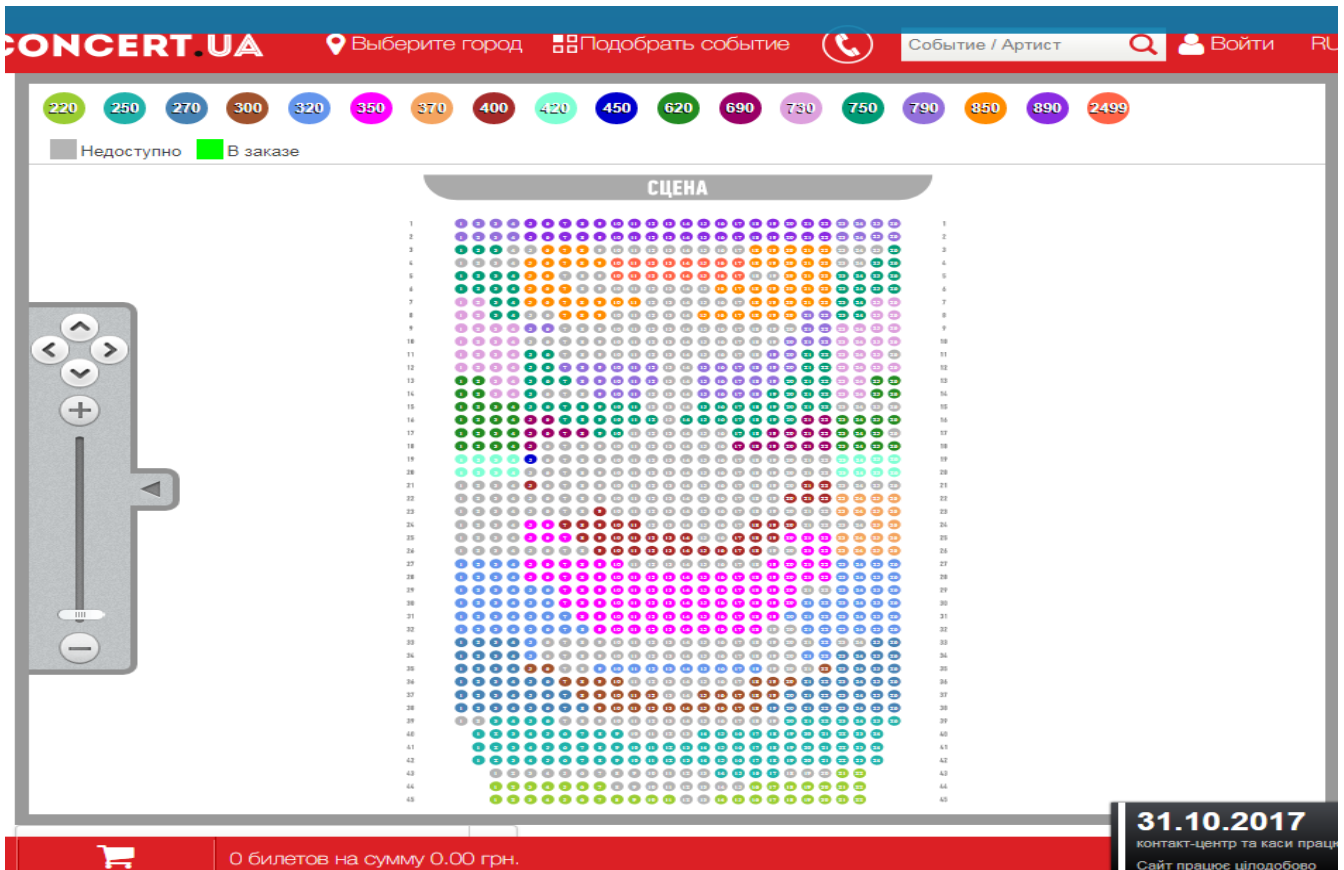
- For group visits (from 10 people) 15% discount.
- How can you put together a group for a trip?

• Write the text for the announcement in your social network feed

• As you know, no group trip is complete without a package of documents, which includes a list of participants with certain data.

--	--	--	--

- Hurry up to book tickets at the best price for the seats convenient for you!



- What criteria did you follow when choosing places?

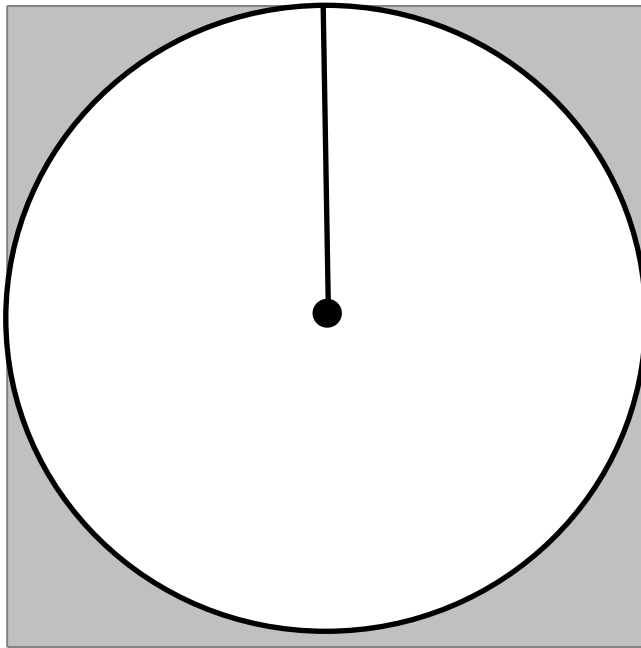
1. _____

2. _____

3. _____

- You can get to Kiev in different ways. What type of transport is best to do this? Depending on what type of transport you will go to the capital, calculate the cost of travel.

- Approve your trip budget with your parents as they can sponsor 1/2 of your trip.

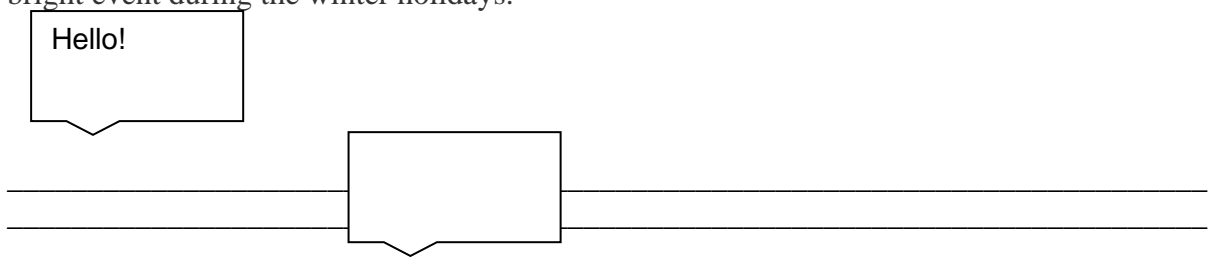


<input type="checkbox"/> 1.	Event Ticket
<input type="checkbox"/> 2.	
<input type="checkbox"/> 3.	
<input type="checkbox"/> 4.	
<input type="checkbox"/> 5.	
<input type="checkbox"/> 6.	
<input type="checkbox"/> 7.	
<input type="checkbox"/> 8.	
<input type="checkbox"/> 9.	
<input type="checkbox"/> 10.	

- To be in the right place at the right time, you need to manage this time.
Time – management

7-00
8-00
.....
22-00

- At the time of preparation for the trip you called your American friend. Tell him about your bright event during the winter holidays.



- At the moment you do not have the necessary amount for the trip. How can you bring yourself closer to the dream and make it come true during the winter holidays?

References

1. Altshuller G.S. «Find the Idea. Introduction to the theory of solving inventive problems». Petrozavodsk, Scandinavia, 2003.
2. Barkan M., Guin A. «Developing creative and critical thinking skills in next generation workforce».
3. Galperin P. Y. «The method of "slices" and the method of step-by-step formation in the study of children's thinking». Questions of psychology. 1996. No. 4.
4. Gin A.A., Barkan Mark. «Open tasks as an instrument for the development of creative thinking». Moscow, Public Education, 2014.
5. Gin A.A., Kavtreev A. F. «Creativity: how to conduct it». Moscow, Vita-Press, 2015.
6. Gredinarova E.M. «System-genetic approach in education». Kiev, Collection of scientific articles, 2008.
7. Gredinarova E.M. «Scheme-model of the functional-system approach as a tool for systematization of students' knowledge and the formation of systemic and creative thinking: a methodological guide for teachers, psychologists and students». Zaporozhye, Plus73, 2011.
8. Khutorskoy A.V. «Key competencies and educational standards». Eidos Online Journal. 2002.
9. Lebedev O.E. «TRIZ opportunities in the situation of modeling general education». St. Petersburg, MA TRIZ FEST, 2005.
10. Polivanova K.N. «Project activity of schoolchildren». Moscow, Prosveshchenie, 2008.

Communicating Author: gredynarova@gmail.com

TRIZfest 2019

September 11-14, 2019. Heilbronn, Germany

DERIVING QUANTITATIVE CHARACTERISTICS FROM CECA MODEL

Jerzy Chrzęszcz^{a,b}

^a *Institute of Computer Science, Warsaw University of Technology, Warsaw, 00-665, Poland*

^b *Pentacomp Systemy Informatyczne S.A., Warsaw, 02-222, Poland*

Paper Classification:

- TRIZ-related methods and tools development

Abstract

The selection of key disadvantages from all the disadvantages revealed during Cause-Effect Chains Analysis (CECA) is an important stage. Several techniques for supporting this selection have been described in the literature, usually relying on the analysts' knowledge of the analysed system and its context. This paper proposes a complementary approach, based solely on the structure of the CECA model.

The method does not require specific domain expertise and enables algorithmic evaluation of several quantitative parameters for all of the disadvantages, taking into account the position of a given box and its connections within the diagram, as well as logical operators between the boxes. Resulting values may be used – either directly or in combination with experts' estimations – to support selection of the key disadvantages.

Keywords: TRIZ, Cause-Effect Chains Analysis, key disadvantages, logical model, quantitative model.

1 CECA in qualitative and quantitative perspective

Cause-Effect Chains Analysis (CECA) method employs systematic identification of the causal relations between the disadvantages in the analysed system [1, 2]. It starts with indicating key drawbacks of the system (*target disadvantages*), removal of which is the goal of the project. Then their subsequent causes (*intermediate disadvantages*) are investigated, until reaching the primary causes (*root causes*) considered as those remaining beyond control. The model build during the analysis reflects the disadvantages, the flow of causality shown with arrows and – possibly – logical operators indicating how the inputs trigger the output. An AND operator denotes that all input causes must be active to activate the output disadvantage, while for an OR operator the activation of any subset of the inputs (including single input) is sufficient to activate the output disadvantage. Because of their nature, usually the root causes may not be literally eliminated. Therefore CECA procedure aims at selecting the *key disadvantages* instead,

which are deep causes having a big impact on the target disadvantages, so that removing them results in reaching the goal of the project.

In spite of several attempts to make building of a CECA model more systematic [3, 4, 5, 6, 7, 8], detailed rules assuring completeness and correctness of the model have not been established yet. Consequently, the way of documenting the analysis remains a matter of style and practice to a great extent, while models developed for the same problem by different teams may differ significantly. One of the criteria proposed in [7] is described as MECE (Mutually Exclusive Collectively Exhaustive), i.e. the causes identified in each step should not overlap with each other and should jointly cover all possibilities. Although attractive and formally correct, this criterion seems difficult to apply in real situations. Mutual exclusivity requires that the input causes must be independent in the probabilistic sense, and this may be not known during the analysis. Collective exhaustiveness taken literally means that analysts are sure to document ALL possible causes of a given disadvantage, so in order to strictly comply with this requirement, one should probably add “OR other yet unknown causes” to every disadvantage (such as customs tariffs include “not elsewhere classified” category).

CECA method is qualitative in general, but it implicitly relies on quantitative decisions that determine the scope of the model, as it was shown in the context of risk-based approach [9]. It would be usually impractical to cover causes that do not contribute significantly to the analysed problem and therefore some known but negligible phenomena (e.g. attraction of the Moon) are intentionally ignored. In other words usability of the model is more important than its formal completeness. The real challenge, however, is to decide where to stop, and because of time-boxing project regime the “where” is often replaced by “when”, i.e. the analysis stops when its time elapses. This is a sign of a quantitative approach, because such decision means that the consequences of disregarding those unidentified causes were considered less dangerous than exceeding analysis deadline.

A method of converting a CECA diagram into a set of combinatorial logical functions was proposed in [10]. All disadvantages were represented as binary variables. Logical operators (AND, OR) were modelled as gates with the appropriate numbers of inputs and intermediate disadvantages in linear chains were removed [2, 11]. The final model comprised only input variables (root causes) affecting output variables (target disadvantages) through a network of AND/OR gates interconnected as in the original CECA diagram. In spite of the introduced simplifications the logical model supported algorithmic derivation of some important qualitative and quantitative characteristics, as described in section 3. Several enhancements to this method, including proper representation of intermediate disadvantages and quantitative extensions, were introduced in [9] and [12], while [13] proposes a conversion of a CECA diagram, perceived as a collection of harmful processes “producing” target disadvantages, into a state-machine model.

2 Selecting key disadvantages

Selection of the key disadvantages from all the disadvantages revealed during the analysis is an important stage in the process of formulating key problems to be solved. Several techniques for supporting this selection have been described in the literature [4, 11, 14, 15, 16], usually relying on the analysts’ knowledge about the analysed system and its context. In general, however, eliminating key disadvantages should eliminate target disadvantage (or disadvantages) with minimal cost, expressed as money or workload or using other project-specific measures. Simply put, one should look for impactful disadvantages that are easy (cheap, fast, etc.) to remove.

Depending on the logical relations between the disadvantages, there may be several candidate solutions available, requiring elimination of particular groups of the key disadvantages [11, 15]. Unfortunately, systematic selection of the “best” group of key problems to solve using the profitability criteria would require credible estimations regarding impact of particular key disadvantages as well as costs of solving respective key problems, what makes practical use of this approach questionable at best. Therefore some heuristics have been proposed for supporting the key problem selection by using proven business rules [15] or simple scales to enable ranking of the estimated attractiveness of the candidates without calculating exact profitability values [9].

For the purpose of this paper, let us use a generic formula expressing the profitability as a quotient of benefit and cost of delivering this benefit (here: eliminating the target disadvantages by solving a pertinent group of key problems). Firstly, we will focus on the numerator, reflecting the total impact of the respective key disadvantages on target disadvantages, which in turn will be considered as a sum of *impact factors* contributed by particular key disadvantages. Hence in order to maximize the profitability, one should look for disadvantages with a high impact factor to be selected as the key disadvantages. Different impacts of the causes contributing to particular effect may be assigned by an expert using specific domain knowledge, failure statistics or other sources. On the other hand, the effective impact of a particular cause also depends on the path from that cause to the target disadvantage, including the number and type of the logical operators. And these properties depend solely on the structure of interconnections between the disadvantages and operators, enabling calculation of such structural impact factors without any domain-specific knowledge.

3 Introducing structural impact factors

For each of the disadvantages in the CECA model (excluding the root causes, which have no predecessors), exactly one of the following conditions applies [9]:

- given effect depends on one cause entirely (i.e. it is a segment of a linear chain), so that elimination of that particular cause would eliminate the effect,
- given effect appears if ALL the contributing causes appear jointly (logical AND), so that elimination of ANY of these causes is sufficient to eliminate the effect,
- given effect appears if ANY or several contributing causes appear (logical OR), so that elimination of ALL these causes is required to eliminate the effect.

Therefore the rules for scaling of the impact factors for *developing* the disadvantages are as follows:

- for a segment of a linear chain the input is assigned factor 1, because activation of the input activates the output disadvantage,
- for N-input AND gate each of the inputs is assigned factor $1/N$, because all of the inputs must be active to activate the output disadvantage,
- for N-input OR gate each of the inputs is assigned factor 1, because activation of a single input is sufficient to activate the output disadvantage.

In case of *removing* the disadvantages, the scaling should be performed in a different way:

- for a segment of a linear chain the input is assigned factor 1, because deactivation of the input deactivates (eliminates) the output disadvantage,

- for N-input AND gate each of the inputs is assigned factor 1, because deactivation of a single input is sufficient to deactivate the output disadvantage,
- for N-input OR gate each of the inputs is assigned factor 1/N, because all of the inputs must be deactivated to deactivate the output disadvantage,

These rules allow for calculating the structural impact factor between any pair of disadvantages by traversing the model backwards from target disadvantages to the root causes and adjusting the factors for each level of causes. This will be described in section 4.

An illustration of the above-mentioned rules is given in Fig. 1 depicting a sample CECA model with two target disadvantages ($y1, y2$), four root causes ($x1 \div x4$) and five intermediate causes ($x5 \div x9$). In spite of relatively low number of disadvantages, the different logical operators together with $x2$ and $x3$ connected to various levels of the structure, make it a bit challenging to realize how the inputs affect the outputs. This model may be described in a formal way using logical functions (plus sign denotes OR, concatenation denotes AND) and transformed to find the minimal form:

$$y1 = x6x8 = x2x3x5x7 = x2x3(x1+x2)(x3+x4) = x2x3(x1x3+x1x4+x2x3+x2x4) = x2x3$$

$$y2 = x6+x9 = x2x3+x5+x7 = x2x3+x1+x2+x3+x4 = x1+x2+x3+x4$$

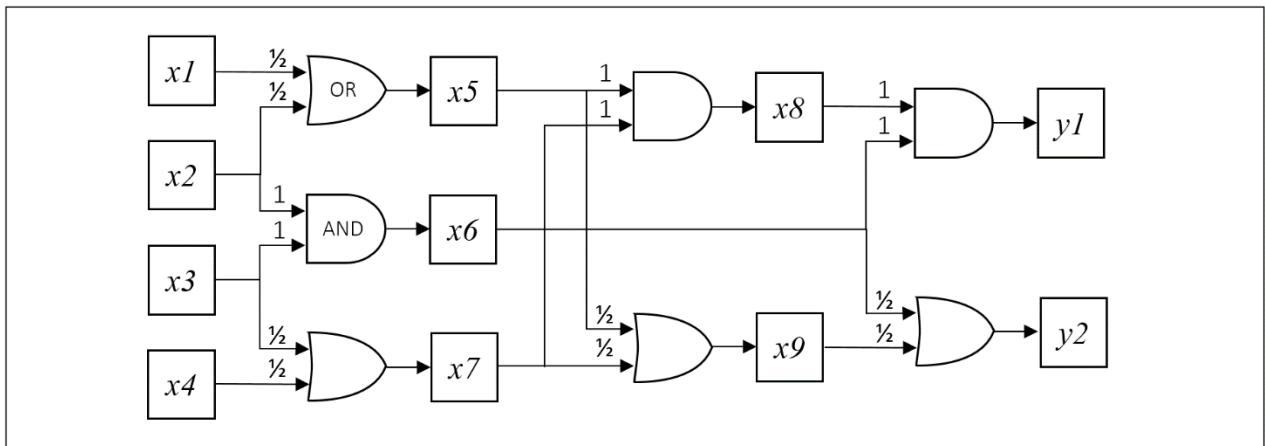


Fig. 1. Sample cause-effect diagram with indicated scaling of impact factors for removing disadvantages

To find the analytical representation of a solution – i.e. the conditions describing elimination of the key disadvantages – we use logical negation of the functions (denoted with an apostrophe) calculated using rules of Boolean algebra [10]:

$$y1' = (x2x3)' = x2'+x3'$$

$$y2' = (x1+x2+x3+x4)' = x1'x2'x3'x4'$$

With these equations, some quantitative characteristics may be calculated as well, e.g. by counting the instances of the variables it may be easily discerned, that $x2$ and $x3$ have greater impact on the target disadvantages than $x1$ and $x4$.

Doing similar transformations manually is error-prone and impractical in case of complex models. Programmatic approach, in turn, requires symbolic processing (which is available in some

math software packages). The proposed quantitative approach using structural impact factors allows for obtaining similar results with a much simpler processing.

4 Calculating structural impact factors

In order to represent a CECA diagram in a form appropriate for programmatic processing, it needs to be converted into a *causality matrix*. This is a square matrix having rows and columns labelled with identifiers of the disadvantages put in the same order for both dimensions. The causality matrix indicates how the outputs are connected to the inputs, and it is not symmetrical, as a rule. The rows represent the effects and the columns represent the causes, so that the value in the cell $[m, n]$ is positive if and only if the disadvantage n is a direct cause of the disadvantage m , and it is 0 otherwise. Causality may be modelled with equal values, or the values may differ to indicate expert estimation of unequal importance (strength, intensity, etc.) of particular input causes.

A snapshot of an MS Excel worksheet describing the sample CECA model is given in Fig. 2a (empty cells are recognized as 0s). An additional field is used in each row for recording type of the logical operator combining the input causes (AND / OR / none). There are also fields provided for storing counters of non-zero cells in each row and each column as well as other parameters used during calculations. Zero in a row counter indicates that given row represents a root cause (a disadvantage with no predecessors in the diagram) and zero in the column counter indicates that given column represents a target disadvantage (with no successors in the diagram).

Figure 2 consists of two Excel worksheets, (a) and (b), showing the causality matrix and its calculated impact factors.

Worksheet (a) shows the raw causality matrix. The columns are labeled 'causes' (x1-x9) and 'effects' (y1-y2). The rows are labeled 'effects' (y1-y2). The cells contain 0 or 1, indicating direct causality. Below the matrix, there are columns for 'operators' (AND, OR, none), 'level', 'source', 'value', 'analysis', 'numerator', 'denominator', and 'temporary'.

Worksheet (b) shows the calculated impact factors. The cells contain percentage values (e.g., 50, 100, 12,5) representing the impact factor for each cell. The structure is identical to (a).

Fig. 2. Causality matrix of a sample CECA model shown in Fig. 1 (a) and the calculated impact factors (b)

For each row of the causality matrix the impact factors are calculated using information about direct causes of respective disadvantage and their subsequent causes, taking into account logical operators, until reaching root causes. In each iteration previously calculated factors are recalculated and if same cause affects given disadvantage through several paths (possibly at different levels of nesting), this is reflected by adding contributing factors. Finally, the results are scaled and formatted to indicate percentage values and stored in another matrix of same structure, as shown in Fig. 2b. For instance $x1$ propagates to $y1$ via one OR and two AND gates, so the factor equals $\frac{1}{2} \cdot 1 \cdot 1 = 50\%$, while for propagation from $x1$ to $y2$ the path includes three ORs and the factor is $\frac{1}{2} \cdot \frac{1}{2} \cdot \frac{1}{2} = 12,5\%$.

The generic algorithm of the calculation may be described in the iterative form as follows below. This is a simplified, illustrative pseudo-code with impact factor calculation and other processing details omitted, but it correctly reflects the main operations used in the actual implementation.

```

FOR each row of the causality matrix
    initialize the current-level list of input causes as empty
    append indices of all non-zero items in the row to the current-level list of input causes
    WHILE current-level list is not empty
        initialize the next-level list of input causes as empty
        FOR each element of the current-level list
            calculate or recalculate structural impact factor of the respective input
            select the row indicated by the current element of the current-level list
            append indices of all non-zero items in the row to the next-level list of input
causes
        END FOR
        make the next-level list the current-level list
    END WHILE
END FOR
    
```

Let us consider row 10 of the causality matrix (describing $y1$) and the lists of causes on subsequent levels of the structure, together with the calculated impact factors:

	$x1$	$x2$	$x3$	$x4$	$x5$	$x6$	$x7$	$x8$	$x9$
level 1 – 6, 8 (AND)						1		1	
level 2 – 2, 3 (AND) 5, 7 (AND)		1·1	1·1		1·1	1	1·1	1	
level 3 – 1, 2 (OR) 3, 4 (OR)	1·½	1+½	1+½	1·½	1	1	1	1	
scaled result – as in Fig. 2b	50	150	150	50	100	100	100	100	

And for the row 11 (describing $y2$) the sequence is as follows:

	$x1$	$x2$	$x3$	$x4$	$x5$	$x6$	$x7$	$x8$	$x9$
level 1 – 6, 9 (OR)						½			½
level 2 – 2, 3 (AND) 5, 7 (OR)		½·1	½·1		½·½	½	½·½		½
level 3 – 1, 2 (OR) 3, 4 (OR)	¼·½	½+¼·½	½+¼·½	¼·½	¼	½	¼		½
scaled result – as in Fig. 2b	12,5	62,5	62,5	12,5	25	50	25		50

Some cells of the result table with calculated values are color-coded to indicate the root causes (orange) and their direct successors (yellow), being the deepest elements in a particular cause-effect chain. In case of a regular tree-like structure of a diagram with equal weights of inputs, the subsets of results indicating causes combining to complete removal of a given disadvantage sum up to 100 (as $x6$ eliminating $y1$ by 100% or $x5$, $x6$, $x7$ eliminating $y2$ by 25%, 50% and 25%, respectively). For multi-path propagation the values may total more than 100 (like $x2$, $x3$

for $y1$ are assigned 150% each). And if the input data is weighted, the weights are used multiplicatively to scale the final results, thus combining the structural impact factors with the expert estimations. The causes with the greatest impact factors are good candidates for the key disadvantages.

Several additional parameters are recorded during traversing of the causality matrix, like information regarding levels of causes influencing given disadvantage and sources of the inputs (indicated as the cause indices), as shown in Fig. 3. For instance $x3$ affects $y2$ on level 2 via $x6$ as well as on level 3, via $x7$ and $x9$, hence levels 2 and 3 are indicated in respective cell, while the connection to $x3$ was identified during processing of row 6 and row 7, so they are both indicated as sources.

Figure 3 consists of two matrices, (a) and (b), showing CECA model parameters. Matrix (a) shows levels of interaction, and matrix (b) shows sources of input causes. Both matrices have 12 rows (causes/effects x1-x9, y1, y2) and 14 columns (ID, 1-14). Matrix (a) has a 'level' column and matrix (b) has a 'source' column. Values are highlighted in yellow.

		ID	1	2	3	4	5	6	7	8	9	10	11	12	13	14
		causes	x1	x2	x3	x4	x5	x6	x7	x8	x9	y1	y2			
		effects	x1	x2	x3	x4	x5	x6	x7	x8	x9	y1	y2			
1	x1															
2	x2															
3	x3															
4	x4															
5	x5		1	1												
6	x6			1	1											
7	x7				1	1										
8	x8		2	2	2	2	1			1						
9	x9		2	2	2	2	1			1						
10	y1		3	23	23	3	2	1	2	1						
11	y2		3	23	23	3	2	1	2			1				
12																
			input	result	level	source	value	analysis	numerator	denominator	temporary					

		ID	1	2	3	4	5	6	7	8	9	10	11	12	13	14
		causes	x1	x2	x3	x4	x5	x6	x7	x8	x9	y1	y2			
		effects	x1	x2	x3	x4	x5	x6	x7	x8	x9	y1	y2			
1	x1															
2	x2															
3	x3															
4	x4															
5	x5			5	5											
6	x6				6	6										
7	x7					7	7									
8	x8		5	5	7	7	8			8						
9	x9		5	5	7	7	9			9						
10	y1		5	65	67	7	8			10	8	10				
11	y2		5	65	67	7	9			11	9		11			
12																
			input	result	level	source	value	analysis	numerator	denominator	temporary					

Fig. 3. Additional CECA model parameters: levels of interaction (a) and sources of input causes (b)

Having the individual impact factors calculated, we may compare and rank the causes against each other. Another interesting measure is the aggregated impact of a particular cause, calculated by summing up structural impact factors of a given cause for all target disadvantages.

As indicated in [9], the knowledge of the nature of a disadvantage may support forecasting of the level or relative amount of effort (and thus costs) required to eliminate that disadvantage. Using previous experience with risk evaluation, we applied non-linear scale indicating cost estimated through perceived complexity of the problem to solve and expressed with clearly distinguishable values (easy – 1, medium – 10, complex – 100, root cause – 1000). Finally, in addition to individual structural impact factors, the forecasted profitability of removal is calculated for each cause:

$$profitability = aggregated\ impact\ on\ target\ disadvantages / estimated\ cost\ of\ removal$$

The results of applying this approach to the CECA diagram discussed before are shown in Fig. 4. Following the scale, the root causes ($x1 \div x4$) have been assigned cost label 1000 and all intermediate causes ($x5 \div x9$) have been given cost estimate 100. As can be seen in the graphs, $x2$ and $x3$ exhibit the strongest aggregated structural impact, but due to differences in forecasted costs of removal, the most promising candidates for key disadvantages seem $x6$, $x5$ and $x7$.

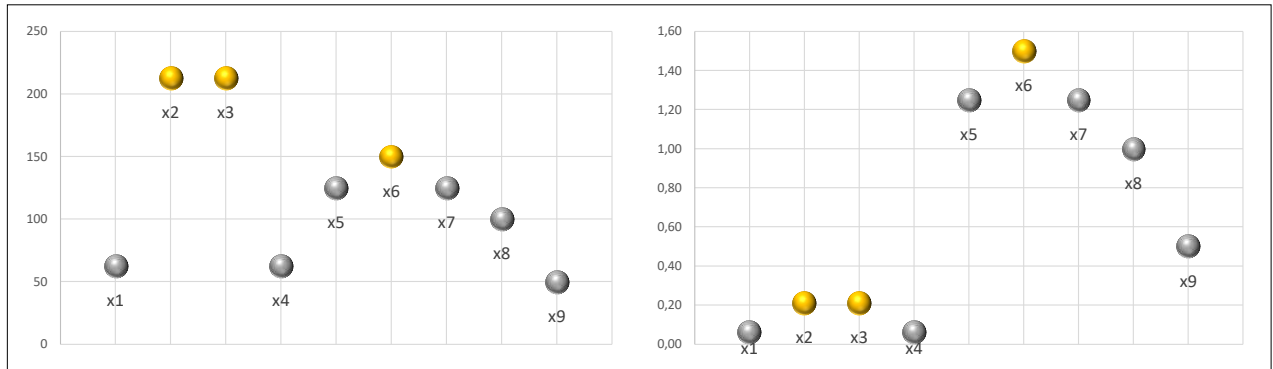


Fig. 4. Aggregated impact of $x1 \div x9$ (left) and estimated profitability of removing particular causes (right)

5 Application and results

The method described in the previous sections was implemented as a Visual Basic program embedded in an MS Excel workbook (shown above in the screenshots with sample data). The workbook was used in an ongoing AirVein project, aimed at developing system for delivering urgent medical shipments using specialized cargo drones. The CECA diagram developed for the drone contained 4 target disadvantages and over 70 disadvantages in total, with nesting of up to 8 layers. The problems covered in the analysis ranged from power sources and engines to noise reduction and de-icing.

Initially, the causality matrix was populated with 1s, like in the presented example. Because the intermediate factors change multiplicatively or additively, as the subsequent layers of model are traversed, it was found useful to represent them as fractions, with numerators and denominators calculated separately during processing and then used at the very end to render the final values of the structural impact factors.

In order to facilitate the use of the workbook, each row was given additional attributes, indicating the system *area* (power train, control, communication, etc.) and the *aspect* or nature of the respective disadvantage (materials, construction, software, etc.). This labelling together with filtering enabled easier browsing and analysing of the results. In such form the workbook was passed to experts for assessing the relative importance of particular causes (to differentiate impact coming from unequal intensity or frequency of manifestation, regardless of the location in the model) and estimating the cost of removal. The results of calculations are depicted in Fig. 5.

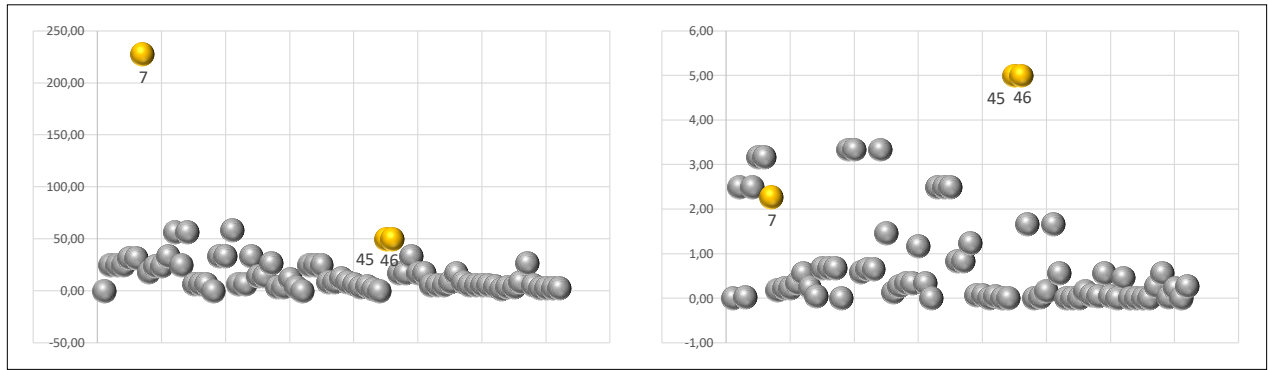


Fig. 5. Aggregated impact (left) and estimated profitability of removing causes in a real-life example (right)

As in the previous example, the initial ranking based on aggregated impact differs significantly from the profitability ranking – note the positions of items 7, 45 and 46 indicated in the diagrams.

To avoid endless looping in case of cyclic paths in the diagram, a feedback verification step was added to the algorithm and in addition to the previously mentioned parameters, for each of the analysed disadvantages the program also calculated the following:

- *operators* – number of the logical operators traversed (ANDs and ORs counted separately),
- *nesting* – maximal number of structure levels from a root cause to a given disadvantage,
- *inputs* – maximal number of logical operator inputs encountered in the path,
- *causes* – total number of causes contributing to a given disadvantage,
- *unique* – number of unique causes contributing to a given disadvantage.

6 Conclusions and further work

The usual approach to selecting of the key disadvantages starts with removing intermediate causes from the linear chains [2, 10, 11]. This practice comes from an observation that root causes and the causes with several incoming or outgoing connections are typically the most promising candidates for the key disadvantages and it is aimed at simplifying the initial CECA model. But on the other hand, removing intermediate causes may result in overlooking many interesting possibilities for eliminating the target disadvantages. Automatic calculation of quantitative characteristics of the model could probably reduce the need for such default simplification.

The concept of structural impact factor addresses differences between influences coming from causes located in different places of a CECA model and the proposed calculation formula reflects the nesting level of the contributing causes as well as the logical operators present in the causality propagation path. These calculations may be performed using structure of the model solely, with no domain expertise required. On top of that, the results may be easily combined with experts' estimations regarding relative importance or forecasted costs of removing particular disadvantages. This concept has been implemented and applied in an ongoing project, showing its usability in supporting the process of selecting the key disadvantages.

Further work may address extending analytical functions, for instance tracking the connections between the causes in the forward direction (in addition to backward propagation analysed so far). Perhaps the impact factors of the causes with more successors in the model should be additionally increased to reflect their “horizontal” or “systemic” influence, thus making them better candidates for the key disadvantages than other causes having equal scores.

It might be also noticed, that the described quantitative characteristics refer to individual causes, while removing a target disadvantage usually requires elimination of several key disadvantages [11, 14, 15]. Hence, a more appropriate ranking should use measures aggregated over subsets of causes, removal of which is sufficient to eliminate a target disadvantage. Probably the alternative solutions equivalent to analytical derivation of a negated expression describing a logical function (as shown in the section 3) may be obtained using a causality matrix without symbolic processing.

The crucial part of the described process is the conversion between graphic form of the CECA model and the initial causality matrix representation, because any errors made at this stage affect all the following calculations. Therefore development of a method supporting verification of the transformation of the input CECA diagram into a table seems an interesting research subject as well.

Acknowledgements

Author gratefully acknowledges Mr. Dariusz Burzyński for his linguistic support.

References

1. Litvin S.S., Akselrod B.M. “Cause-Effects Chains of Undesired Effects, Methodical Theses” (in Russian). CPB, 1996.
2. Abramov O., Kislov A. “Cause-Effect Analysis of Engineering System’s Disadvantages, Handbook on Methodology” (in Russian), Algorithm, Ltd., 2000.
3. Souchkov V. “Root Conflict Analysis (RCA+): Structuring and Visualization of Contradictions”. In: Jantschi J. (ed.) Proceedings of the ETRIA World Conference TRIZ Future 2005. Graz, Austria. pp. 474-483. Leykam Buchverlag 2005.
4. Pinyayev A.M. “A Method for Inventive Problem Analysis and Solution Based On Why-Why Analysis and Functional Clues”. TRIZ Master Thesis, 2007.
5. Medvedev A.V. “Algorithm for Automated Building of Cause-Effect Chains of Disadvantages” (in Russian). TRIZ Master Thesis, 2013.
6. Yoon H. “Occasion Axis and Parameter-Function Pair Nexus for Effective Building of Cause Effect Chains”. In: Souchkov V., Kässi T. (eds.) Proceedings of the TRIZfest-2014 International Conference, Prague, Czech Republic, pp. 184-194. MATRIZ 2014.
7. Lok A. “A Simple Way to Perform CECA And Generate Ideas in Practice”. In: Souchkov V. (ed.) Proceedings of the TRIZfest-2017 International Conference. Krakow, Poland, pp. 23-30. MATRIZ 2017.
8. Lee M.G., Chechurin L., Lenyashin V. “Introduction to cause-effect chain analysis plus with an application in solving manufacturing problems”, International Journal of Advanced Manufacturing Technology (2018) 99: pp. 2159–2169.
9. Chrzęszcz J. “Quantitative approach to Cause-Effect Chains Analysis”. In: Souchkov V. (ed.) Proceedings of the TRIZfest-2017 International Conference. Krakow, Poland, pp. 341-352. MATRIZ 2017.

10. Chrzęszcz J., Salata P. "Cause-Effect Chains Analysis using Boolean algebra". In: Koziółek S., Chechurin L., Collan M. (eds.) *Advances and Impacts of the Theory of Inventive Problem Solving. The TRIZ Methodology, Tools and Case Studies*, 2018, ISBN 978-3-319-96531-4, pp. 121-134.
11. Pavlov V.V. "Method for Building a Map of Key Problems" (in Russian), 2001. [online] <http://www.triz.natm.ru/articles/pavlov/pavlov01.htm>, Last seen on June 30, 2019.
12. Chrzęszcz J. "Indicating System Vulnerabilities Within CECA Model". In: Mayer O. (ed.) *Proceedings of the TRIZfest-2018 International Conference*, Lisbon, Portugal, pp. 31-37, MATRIZ 2018.
13. Chrzęszcz J. "Modelling CECA diagram as a state machine". In: Cavallucci D., DeGuio R., Koziółek S. (eds.) *Automated Invention for Smart Industries, 18th International TRIZ Future Conference TFC 2018 Proceedings*, IFIP AICT, vol. 541, 2018, ISBN 978-3-030-02455-0, pp. 302-314.
14. Efimov A.V. "Identification of Key Disadvantages and Key Problems using Cause-Effect Chains of Undesired Effects" (in Russian), 2011. [online] <http://www.metodolog.ru/node/993>. Last seen on June 30, 2019.
15. Abramov O.Y., Savelli S. "Identifying Key Problems and Conceptual Directions: Using the Analytical Tools of Modern TRIZ". In: Mayer O. (ed.) *Proceedings of the TRIZfest-2018 International Conference*, Lisbon, Portugal, pp. 55-68, MATRIZ 2018.
16. Lok A. "Selecting and Validating Key Problems in TRIZ Projects". In: Mayer O. (ed.) *Proceedings of the TRIZfest-2018 International Conference*, Lisbon, Portugal, pp. 158-169, MATRIZ 2018.

Communication

Communicating Author: jch@ii.pw.edu.pl

TRIZfest 2019

September 11-14, 2019. Heilbronn, Germany

DESIGN OF ROBOT SELF-CLEANING VISION SYSTEM BASED ON TRIZ AND MULTI-COUPPLING BIOMIMETIC TECHNOLOGY

Junlong Chen, He XU, Vishwanath Pooneeth, Zitong Zhao, Xueshan Zhou, Haihang Wang,
Feng Sun

*College of Mechanical and Electrical Engineering, Harbin Engineering University,
Harbin, 150001, China*

Paper Classification:

- TRIZ-related methods and tools development

Abstract

In order to design the vision system of a robot working in a harsh environment, a method combining TRIZ and multi-coupling bionics was proposed. Through this method, an engineering model was designed according to several biological prototypes. First of all, the TRIZ was chosen to analyze the innovation problem, and a multi-biological prototype was selected. Next, the main coupling element was selected by the extension analysis method, and the similarity evaluation was carried out. Finally, a binocular negative correlation, a high degree of freedom, and a self-cleaning vision system were designed. As a result, the new structure of the vision system validated the efficacy of the proposed method.

Keywords: *self-cleaning vision system, TRIZ, multi-coupling bionics, extension analysis*

1 Introduction

TRIZ is a multi-field applicable innovation methodology that is nowadays popular while bionics is an ancient and a convenient design methodology, which is widely used in production design. As well, both are innovative methods in the field of natural science and engineering technology [1], playing important roles in the field of scientific research and innovation.

Bionics is also a comprehensive interdisciplinary subject using the mechanisms found in the biological world to solve human needs and opens a new era to promote learning [2]. However, today's bionics also encounters a bottleneck period that is difficult to break through: single-element bionics still dominates [3], the single biological structure has been explored and developed to be almost perfect, and it is difficult to meet today's ever-changing product functional requirements. Hence, the advent of multi-coupling bionics has come up in being popular.

Multi-coupling bionics is closer to the actual biology, and it is expected to solve the problem that traditional single-element bionics are difficult to solve. For example, plant leaves such as lotus leaves have significant self-cleaning function, which are coupled by surface morphology, composite structure and surface energy-inducing materials. Learning the coupling principle of these creatures and performing ternary coupling bionics is expected to solve the problem of self-cleaning of high-energy surfaces, which is difficult to solve by single-element bionics such as morphological bionics, structural bionics, and material bionics [4].

"Coupling bionics" is the merging of the mechanism and laws of bio-coupling that combines the theory of extenics, conjugate analysis, and multi-coupling bionics to form an effective tool for both qualitative and quantitative analysis [5]. Multi-element bionics has undoubtedly become the future direction of bionics.

For an explicit understanding of the growth of TRIZ and bionics, Figure 1. below explains the evolution of the technological system in terms of the "S-Curve".

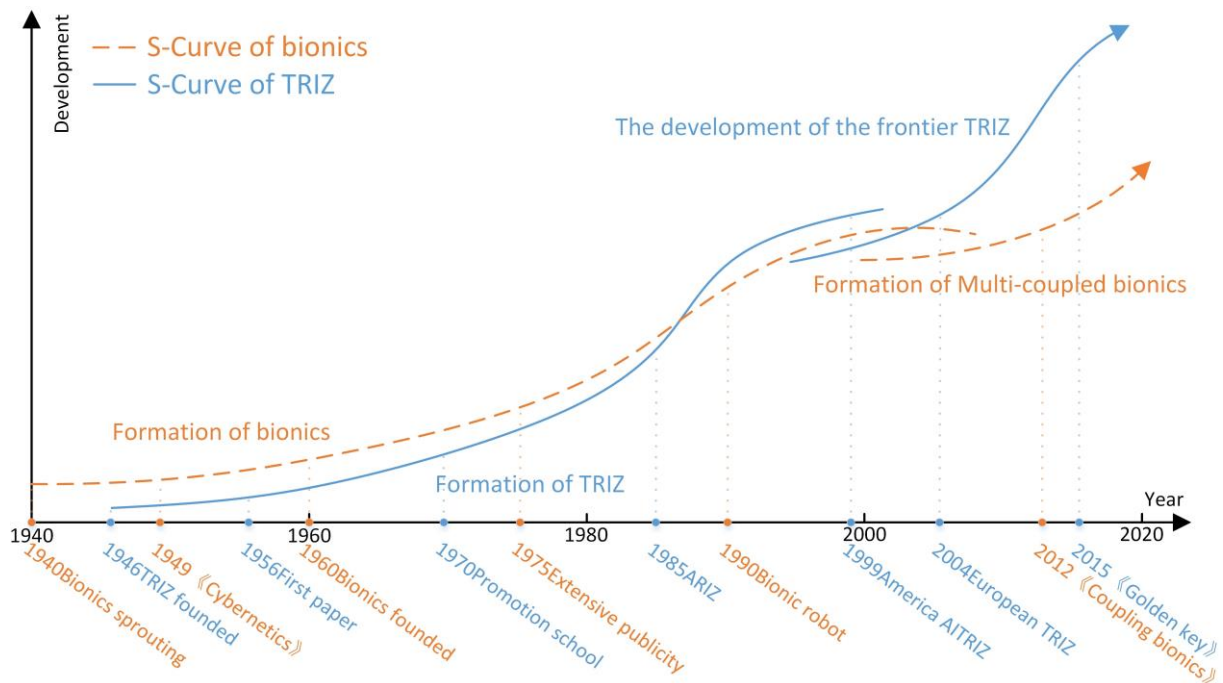


Fig. 1. S-curves of TRIZ and bionics

The picture vividly illustrates the development history and current situation of the two major theories:

1. TRIZ and bionics have similar development history.
2. Since the rise of the emerging TRIZ such as ARIZ in the United States in 1999, there have been many incalculable theoretical breakthroughs and applied innovations. Thus, the frontier TRIZ has gained a new maturity.
3. Multi-coupling bionics is one of the latest development directions of bionics, which promotes the development of bionics from single-element to multi-element, and has shown great vitality in only several years.

From the development process, it can be analyzed that the cycle of coupling bionics is short and is still in growth while TRIZ has reached a new stage of maturity, and has full experience in the application innovation of theoretical research. Although it is highly reliable, at the same time TRIZ has a high degree of generality and abstraction, which limits its presence in certain specific fields. Coupling bionics is highly intuitive, but there is no theoretical support for the selection of biological models. Owing their amazing degree of fit, it is feasible to integrate coupling bionics and TRIZ as an innovative method.

To this end, a method combining TRIZ with coupling bionics was proposed and applied to the design of a robot self-cleaning vision system, which proved its feasibility.

2 Innovative Method Combining TRIZ with Coupling Bionics

According to the above analysis, TRIZ and coupling bionics have their own characteristics. Based on the theoretical innovation design of TRIZ and coupling bionics, their advantages make up for each other's shortcomings and realize theories that can be used for innovative design of products. Hence, a new design method as shown in Figure 2. combining TRIZ and coupling bionics was proposed to select the biological prototype, then the selected biological prototypes are analyzed using the relevant theories of extenics and evaluated using the similarity principle to determine whether the selected biological prototype meets the requirements of bionics.

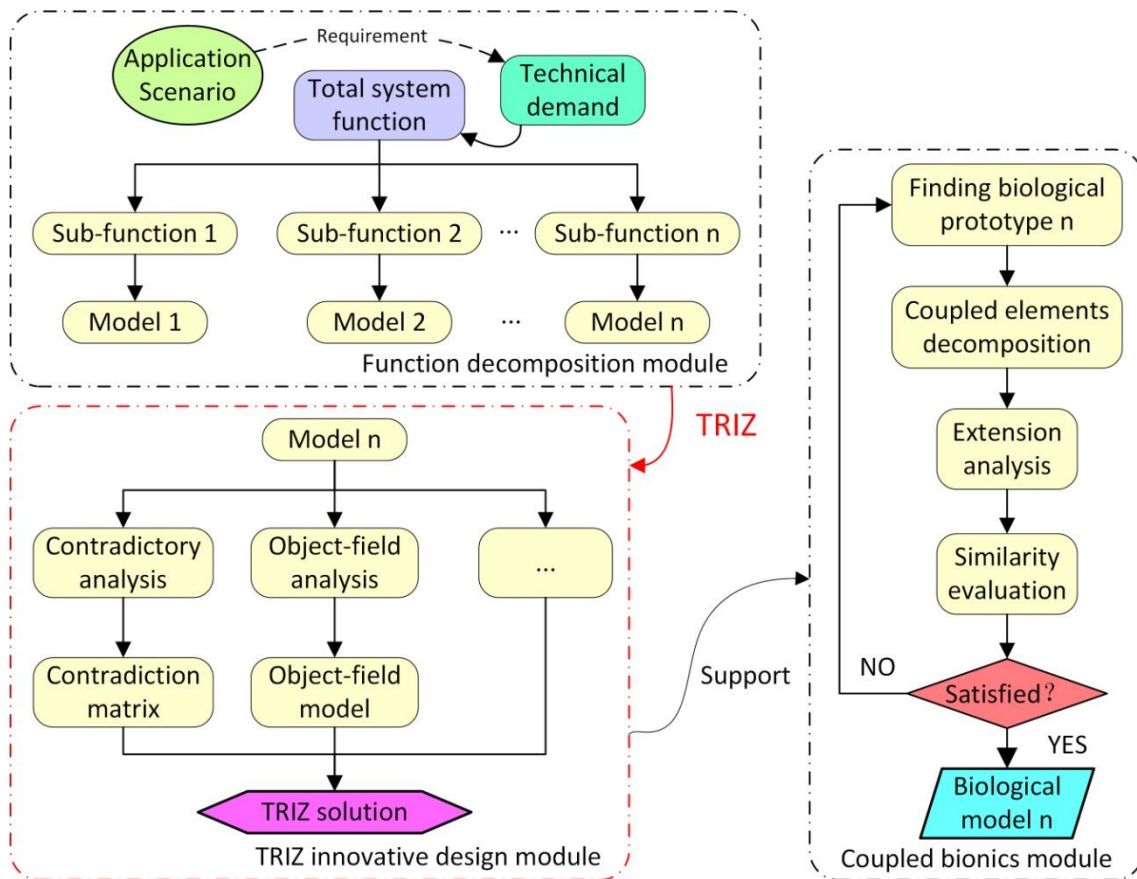


Fig. 2. Innovative design method based on TRIZ and coupling bionics

The requirements of the specific application were analyzed to determine the total function of the system to be sought, and then the total function was decomposed into sub-functions. For

each sub-function, an innovative design approach combining TRIZ with coupling bionics was used to determine a biological model.

3 TRIZ Combined with Coupling Bionics to Determine the Biological Model

With the development of science and technology, mobile robots are being widely used in military, production, home, and many other fields to replace humans in harsh environments. These unstructured environments are complex and unknown, thus the robot needs a search system with a wide range, a self-cleaning lens, and films to clean different hardnesses' dirt.

The functional decomposition of the target product is shown in Table 1.

Table 1

Functional decomposition		
Total function	Sub-function	Sub-goal
Target search in harsh environments	Wide range of search targets	Model 1 to be sought
	Self-cleaning lens	Model 2 to be sought
	Cleaning dirt of different hardness	Model 3 to be sought

For each model to be sought, it is desirable to find a biological model that can achieve its sub-functions and verify the reliability of the model. The following is an example of the model 2 to be sought.

3.1.1 Find Contradictions

TRIZ is used to find contradictions in the design process. It is used here in the process of finding biological models. First look for contradictions that exist during model building and translate them into standard contradictions in TRIZ to get specific solutions. Then, for each of the different models to be sought, the most appropriate TRIZ innovation method was used for the analysis.

If model 2 is to be applied, the functional model is first established to analyze the self-cleaning lens, as shown in Figure 3.

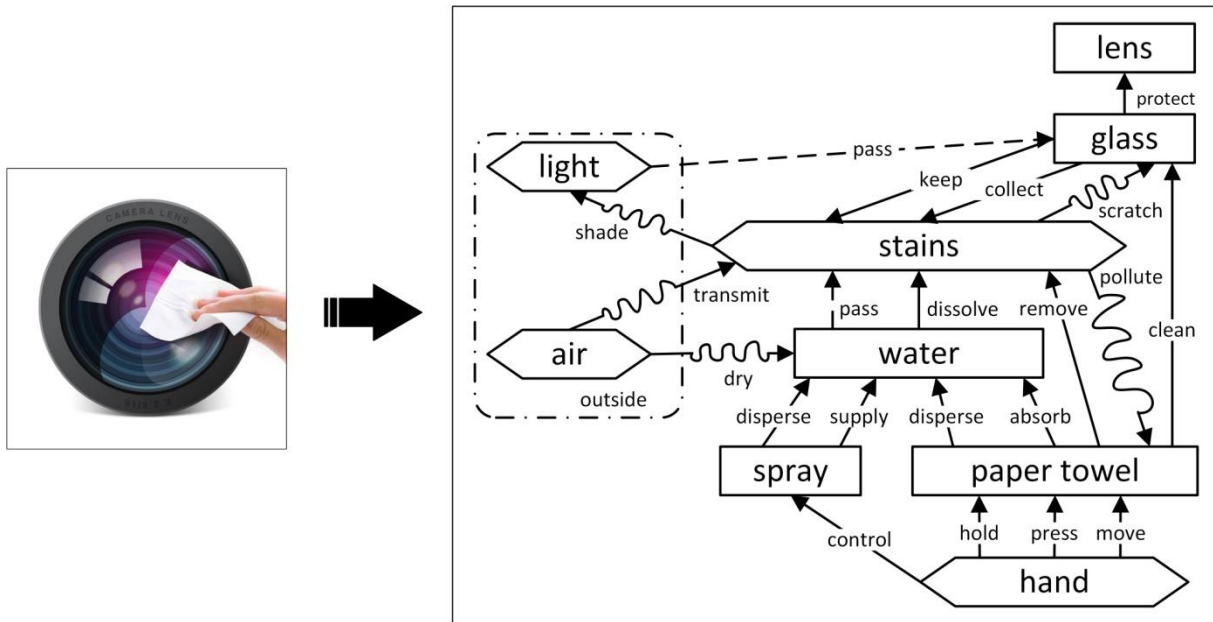


Fig. 3. Functional model for lens cleaning

According to the analysis of the functional model, the following deficiencies and harmful functions existed in the system:

- (1) The control of the spray and the drying of the paper towel requires the participation of the human hand. In some special circumstances, people cannot participate in the cleaning operation.
- (2) The cleaning function relies only on the dissolution of water. This single performance cannot meet the cleaning operation of the mobile robot in multiple working conditions.

3.2 Contradiction Description and Standardization

Through the analysis of the overall system, the defects of the system were determined: low degree of automation and low adaptability. The contradictions of the visual cleaning device listed in Table 2 are converted into TRIZ standard contradictions according to the 39 general engineering parameters.

Table 2

Standardized list of lens cleaning systems

Number	Contradiction	Standard contradiction
1	The cleaning tube is outside the box, but increases the overall volume	No.8 The volume of the stationary object No.12 Shape
2	Want efficient cleaning in unmanned environment with the simplest operation	No.33 Operability No.35 Adaptability

3.3 Solve Contradiction Matrix

Based on the TRIZ contradiction matrix, the principles of the invention are shown in Table 3.

Table 3

Fragment of contradiction matrix

	12	33
8	7,2,35	...
35	...	15,34,1,16

The following solution was obtained:

Solution 1: According to the Nesting principle (No. 7), the liquid cleaning pipe was nested inside the box to reduce the volume of the entire device.

Solution 2: According to the principle of Dynamics (No. 15) and the principle of Segmentation (No. 1), the cleaning device was designed as a movable film structure and jet cleaning.

3.4 Biological Model's Searching and Analysis

With the analysis of the TRIZ, the search for biological models was guided by the final solutions. From the direction of the movable film, the Nesting principle, etc., it was easy to think of the structure of the eyelid, and then perform both the structural analysis and coupling bionic analysis, as illustrated in Figure 4.

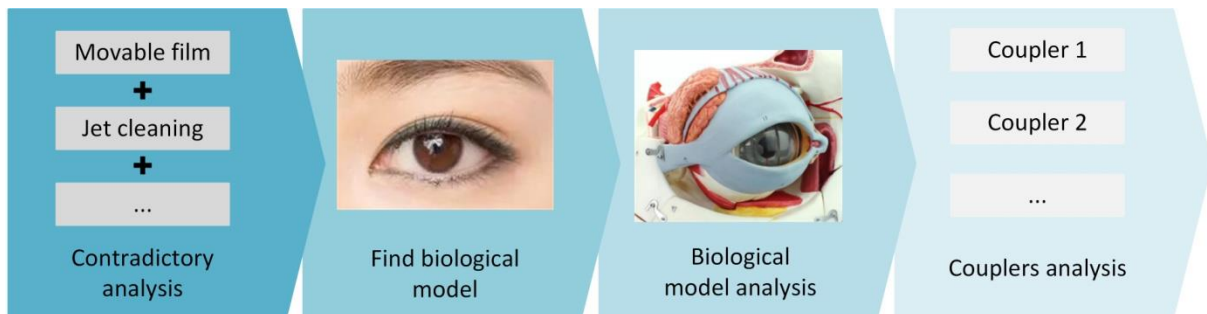


Fig. 4. Biological model search and analysis

3.5 Find the Biological Model of Each Subfunction

For each subfunction to be implemented, the above described method in Section 3.4 was repeated to find its corresponding biological model, as listed in Table 4.

Table 4

Biological model of each subfunction

Subfunction	TRIZ analysis results	Biological model
Wide range of search targets	Independently operated dual camera	Chameleon eyes
Self-cleaning lens	Movable film	Human eyelid
Cleaning dirt of different hardness	Variable stiffness cleaning film	Starfish epidermis

3.6 Coupling Bionics

3.6.1 Coupling Bionics Extension Analysis

The Extension Analytic Hierarchy Process (EAHP) is a method based on the extension set theory to construct a judgment matrix and evaluate it when the problem of relative importance is uncertain [6]. EAHP is used to analyze the coupling elements that affect biological functions to determine the main coupling elements. Taking the cleaning function of human eyelid as an example, the extension level analysis was carried out:

The shape, structure and material of the eyelids were chosen as coupling elements, and the eyelid coupling elements extension model was as follows [7]:

$$M_1 = \begin{bmatrix} \text{structure} & \text{type} & \text{isovolumetric} \\ & \text{composition} & \begin{bmatrix} \text{orbicularis} \\ \text{apertor oculi} \end{bmatrix} \\ & \text{size} & \text{area } 3.5\text{cm}^2 \end{bmatrix}, \quad M_2 = \begin{bmatrix} \text{morphology} & \text{shape} & \text{film} \\ & \text{size} & \begin{bmatrix} \text{thick } 4\text{mm} \\ \text{area } 3.5\text{cm}^2 \end{bmatrix} \end{bmatrix}, \quad M_3 = \begin{bmatrix} \text{material} & \text{characteristic} & \text{bouncy} \\ & \text{organization} & \begin{bmatrix} \text{musculature} \\ \text{syndesm} \end{bmatrix} \\ & \text{component} & \text{bioprotein} \end{bmatrix}$$

Among them, M_1 , M_2 , M_3 is respectively the extension model of structural coupling element, morphological coupling element and material coupling element.

Combined with the functional goals of the eyelid, the structure, shape, and material coupling elements of the eyelids were correspondingly recorded as O_1 , O_2 , and O_3 , which were compared and scored according to the analysis. As shown in Table 5, the three couplers were compared and scored by three different researchers. A score of 1, means that the two factors are of equal importance, and the higher the score, the more important one is. Since the exact score could not be determined, the interval value was given.

Table 5

The score data given by the researchers

	O_1	O_2	O_3
O_1	<1,1>	<0.26,0.47>	<0.22,0.3>
O_2	<2.14,3.86>	<1,1>	<0.36,0.79>
O_3	<3.35,4.65>	<1.26,2.74>	<1,1>
O_1	<1,1>	<0.22,0.29>	<0.22,0.29>
O_2	<3.39,4.61>	<1,1>	<0.48,0.52>
O_3	<3.44,4.56>	<1.92,2.08>	<1,1>
O_1	<1,1>	<0.17,0.24>	<0.18,0.23>
O_2	<4.25,5.75>	<1,1>	<0.26,0.45>
O_3	<4.38,5.62>	<2.22,3.78>	<1,1>

The average of the scores given was calculated as the elements of matrix M , thus the comprehensive judgment matrix M was obtained (here M takes the transposed matrix):

$$M = \begin{bmatrix} [1,1] & [3.26,4.74] & [3.72,4.94] \\ [0.22,0.33] & [1,1] & [1.8,2.87] \\ [0.21,0.27] & [0.37,0.59] & [1,1] \end{bmatrix}$$

Calculated according to the formulas [6]:

$$P_1^b = V(S_1 \geq S_3) = 18.1346, P_2^b = V(S_2 \geq S_3) = 6.1362, P_3^b = 1$$

In the above formula, the intermediate process of calculation is omitted and the final result is retained. Among them, S_1 , S_2 and S_3 respectively shows the importance of each coupling element, and P_1^b , P_2^b and P_3^b respectively shows the relative importance of each coupling element to the lowest one. Thus, the weight vector obtained by normalizing each coupling element's influence on the functional target is:

$$P = [0.718, 0.243, 0.04]^T$$

It could be seen that the contributions of structure, shape and material coupling elements were 0.718, 0.243, and 0.04, which confirmed the structural coupling element of being the main coupling element.

3.6.2 Similarity Evaluation

Let the similarity between the biological prototype and the product design target be recorded as Q , and the value range is: $0 < Q < 1$. The larger the value of Q , the higher the similarity between

the two. The similarity between the eyelid and the design target and the evaluation factor set of the weight coefficient were calculated and selected as follows:

$$U = [u_1, u_2, u_3] = [\textit{structure}, \textit{morpholog}, \textit{material}] = [M_1, M_2, M_3]$$

In the above formula, M_1 , M_2 , and M_3 are extension models constructed in Section 3.6.1. According to the evaluation factors, the similarity judgment matrix N could be obtained by checking the scale table:

$$N = \begin{bmatrix} 1 & 3 & 4 \\ 1/3 & 1 & 3 \\ 1/4 & 1/3 & 1 \end{bmatrix}$$

The weighting vector $W=[0.9027,0.3943,0.1722]^T$ and $\lambda_{max}=3.0735$ were obtained by the finishing calculation. The total consistency index CI was calculated as follows:

$$CI = \frac{\lambda_{max} - n}{n - 1} = 0.0368$$

In the above formula, n represents the quantity of similar features between the biological prototype and the design target, where $n=3$. If the table was found to have the stochastic consistency index $RI=0.5149$, then the consistency ratio CR of the matrix was judged as:

$$CR = \frac{CI}{RI} = 0.0713 < 0.1$$

It can be seen from the above results that the judgement matrix M passes the consistency test. In addition, the similarity of the elements between the biological prototype and the design target was discussed and given by our researchers: $q = [0.7, 0.5, 0.5]$. Therefore, the similarity between the biological prototype eyelid and the design target was: $Q=0.9027 \times 0.7 + 0.3943 \times 0.5 + 0.1722 \times 0.5 = 0.915$, which is close to 1. Thus, according to the similarity evaluation criteria, it could be used as a biological model for bionic design.

3.6.3 Coupling Bionic Analysis of Each Biological Model

The coupling bionics analysis and similarity evaluation was performed on the biological model of each sub-function found based on TRIZ, and the results of the similarity analysis are: $Q_1=0.825$, $Q_2=0.915$, $Q_3=0.882$. The results all met the similarity evaluation criteria.

3.7 Engineering Model Design

According to the above calculation results, it can be seen that three different biological prototypes meet the similarity requirements of the bionic design and have reliability. Next is the bionic design of the main coupling elements of the three biological prototypes, and combined with each other.

Based on each of the biological prototypes found, the overall engineering model design was performed. The variable stiffness cleaning film was designed according to the variable stiffness skin of the starfish, and the cleaning film moving device was designed according to the human eyelid. Then, a wide-range vision system was designed according to the chameleon independent

movement eyes. Finally, each subsystem designed according to the biological model was combined to form a total vision system, as seen in Figure 5.

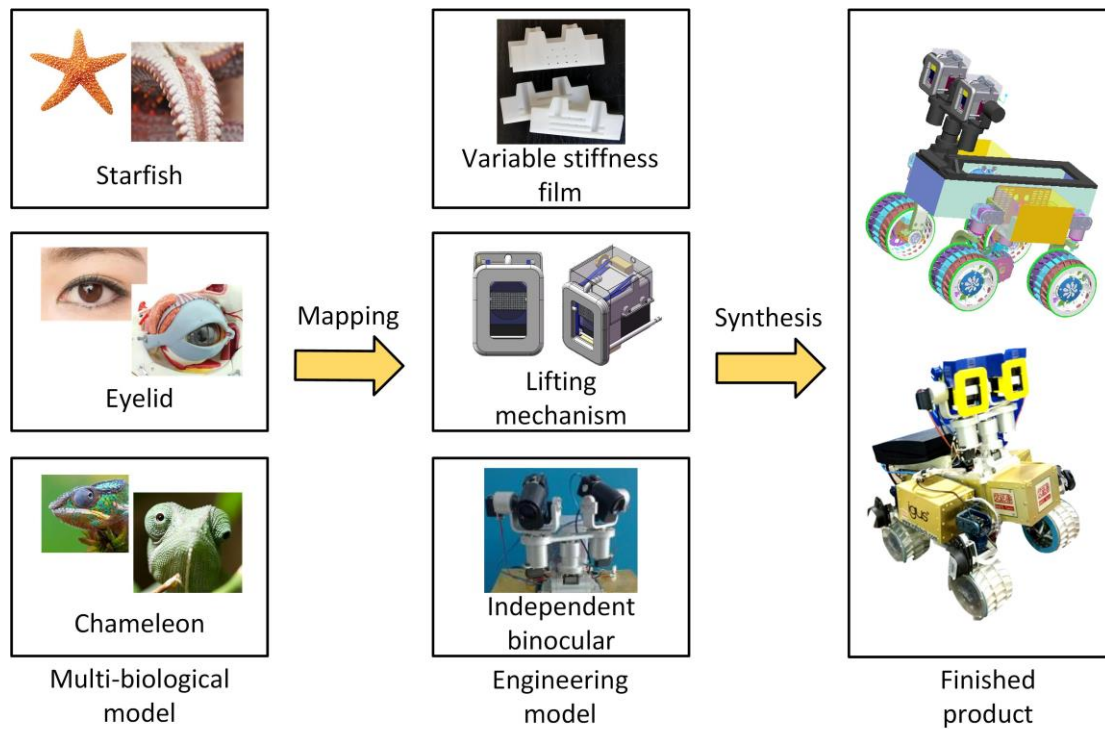


Fig. 5. Engineering model design application

So far, the design of the robot self-cleaning visual system was realized by using the design method based on TRIZ and coupling bionics. This inferred that the vision system had a wide field of view and could self-clean a variety of dirt. It meets the market demand for robots to perform a wide range of search work in harsh environments.

3.8 Experiments

In order to verify the reliability of the vision system and certify the effectiveness of the innovative design method, experiments were conducted.

The large-scale search experiment for the binocular vision system is shown in the Figure 6. The images in the video were captured every 0.5 seconds. As can be seen from the figure, the two cameras can operate independently and search for targets in different directions.

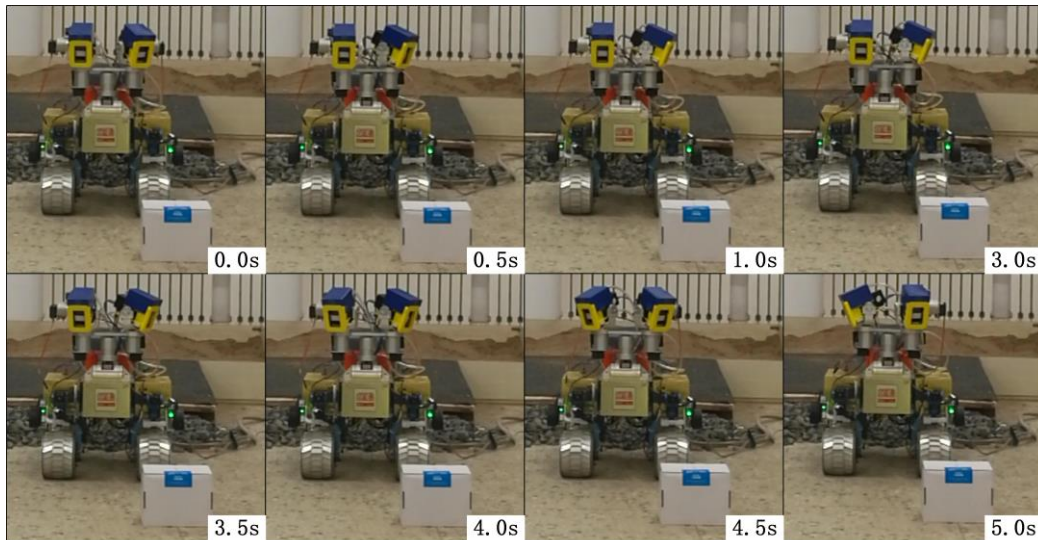


Fig. 6. Large-scale search experiment

The cleaning film movement experiment is shown in the Figure 7. The images in the video were captured every 0.6 seconds. As seen, the cleaning film can be moved up and down to clean the dirt on the lens.

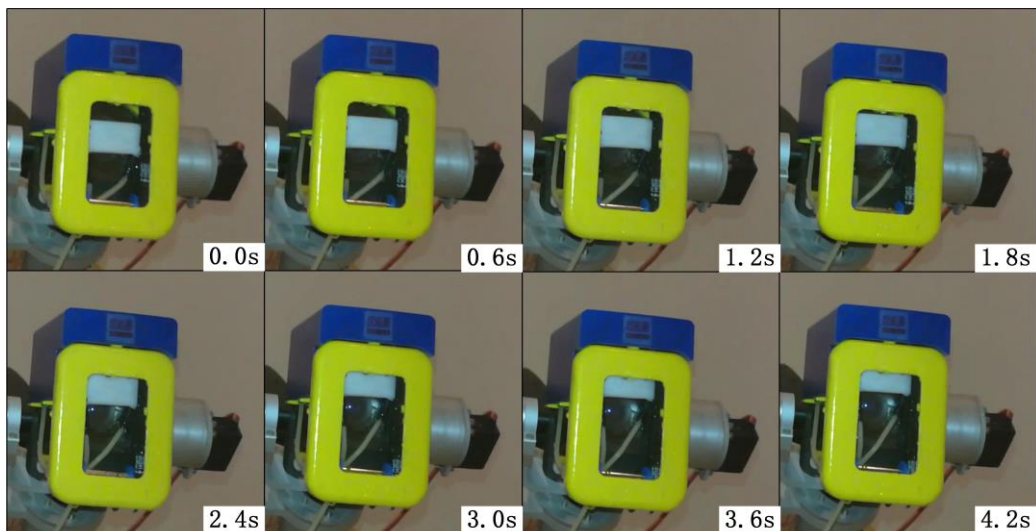


Fig. 7. Cleaning film movement experiment

The above experiments examined the engineering model and verified the reliability of the innovative method based on TRIZ and coupling bionics.

4 Conclusions

This paper proposed a new innovative method combining TRIZ and coupling bionics applied to establish engineering models. Firstly, the total function of the target product was decomposed into several sub-functions, and the biological model of each sub-function was guided by TRIZ. Then the coupling bionics and extension theory were used for analysis, and the similarity evaluation was performed. This method designed a robot vision system for harsh environments, which allowed it to have a wide range of view, do self-cleaning and clean a variety of dirt.

Having its effectiveness verified in this study, this method provides an effective solution to solve other complex engineering problems.

Acknowledgments

This work was supported by the Natural Science Foundation of China under Grant 51875113, Natural Science Foundation of the Heilongjiang Province of China under Grant F2016003, Natural Science Joint Guidance Foundation of the Heilongjiang Province of China under Grant LH2019E027, "Jinshan Talent" Zhenjiang Manufacture 2025 Leading Talent Project, "Jiangyan Planning" Project in Yangzhong City. This paper is funded by the International Exchange Program of Harbin Engineering University for Innovation-oriented Talents Cultivation.

References

1. VINCEN J F V, BOGATYREVA O A. Biomimetics: its practice and theory [J]. *Journal of the Royal Society Interface*, 2006, 3(9): 471-482
2. VINCEN J F V. Biomimetics – a review [J]. *Proceedings of the Institution of Mechanical Engineers, Part H: Journal of Engineering in Medicine*, 2009, 223(H8):919-939
3. Luquan Ren, Yunhong Liang. *Coupling bionics* [M]. Beijing: Science Press, 2012
4. Ren L Q, Liang Y H. Biological couplings: classification and characteristic rules [J]. *Sci China Ser E-Tech Sci*, 2009, 52(10): 2791-2800.
5. Jun Hong. *Multivariate coupling bionics and its effectiveness evaluation* [D]. Jilin University PhD thesis, 2009.
6. Jie Gao, Shaohan Shen. Research on Extension Analytic Hierarchy Process [M]. *System engineering*, 2002, 20(5): 6-11.
7. Jun Hong, Zihui Qian, Luquan Ren. Extensive model of multi-factor coupling bionics and analysis of coupling elements [N]. *Journal of Jilin University (Engineering and Technology Edition)*, 2009

Communication

Communicating Author: Junlong Chen, 315851128@qq.com

TRIZfest 2019

September 11-14, 2019. Heilbronn, Germany

DESIGN OF VARIABLE DIAMETER FLEXIBLE ARM BASED ON TRIZ THEORY AND BIONICS

Fengshu Yu, He Xu, Feng Sun, Peng Li

*College of Mechanical and Electrical Engineering, Harbin Engineering University,
Harbin, 150001, China*

Paper Classification:

- Case study

Abstract

Aiming at the advantages and disadvantages of TRIZ theory and bionics, a design method combining TRIZ theory and bionics was proposed. In the process of mapping engineering problems to biological examples, TRIZ was used to find the principles of invention addressing the engineering problems, hence the biological prototype was found. Then, the biological coupling extension analysis and the establishment of the extension model were carried out. In addition, the similarity between the biological model and the bionic model was evaluated. Finally, the biological model was applied to the product design. For the differences between the bionic model and the biological model and the functional deficiencies of the bionic model, the bionic model were optimized and improved by using the TRIZ principles. In accordance to the design requirements of the flexible arm, in this paper, the design process was applied to the design of the flexible arm. A new structure of bionic flexible arm with variable diameter was designed, which verified the feasibility and effectiveness of this design method.

Keywords: *flexible arm; TRIZ; bionic; variable diameter*

1 Introduction

Product innovation design refers to the process of making full use of human creativity, using existing scientific knowledge to solve various problems in product design, and designing products that meet human needs [1]. Bionics and Theory of Inventive Problem Solving (TRIZ), as two important innovation methods in the field of natural science and engineering technology [2], play important roles in scientific research and innovative design.

TRIZ is the theory that solves the problem of invention and creation. It is a systematic and practical solution to the problem of invention and creation, which was established after analyzing and sorting out millions of patent documents by experts led by Altshuller [3]. The application of TRIZ theory is the process in which conflicts are constantly found in the design process and solved by the invention principles. However, TRIZ theory tends to be highly abstract and

general. Only when designers have a good command of TRIZ theory and the knowledge in the research field, can they better apply this theory.

Bionics is a comprehensive interdisciplinary subject that applies the mechanism and rules found in the biological field to solve human needs [4]. It transplants the highly adaptive functional characteristics of organisms that have evolved over billions of years into the field of engineering design, hence providing intuitive and guiding new methods for scientific and technological innovation. However, the search for biological models lack a theoretical basis, and there are differences between biological models and engineering models, which led to the corresponding optimization should be carried out after the bionic design.

Aiming at the advantages and disadvantages of TRIZ theory and bionics, a design method combining TRIZ theory and bionics was proposed, and the effectiveness and feasibility of the method were verified in the innovative design of the flexible arm.

2 Combination of TRIZ Theory and Bionics

In this paper, the specific process of innovative design with the combination of TRIZ theory and bionics was as follows: Firstly, the functional requirements of products were analyzed and the design conflicts were found out; In addition, the principle of invention that was most suitable for solving problem was found by applying TRIZ conflict matrix, and then the matching biological prototype was found from the biological instance library based on the principles of invention. This article used the biological instance database [5] created by Yanhui Jian of National Cheng Kung University in Taiwan to search for biological examples. Furthermore, the extension analysis of the biological model was carried out, and the similarity between the bionic model and the biological model was evaluated. If the evaluation result failed, the biological model was selected again until the optimal scheme was obtained. Finally, the biological model was applied to the product design to complete the preliminary design of the product. Aiming at the differences between the bionic model and the biological model and the functional deficiencies of the bionic model, the bionic model were optimized and improved by using the TRIZ principles. The whole process was shown in Figure 1.

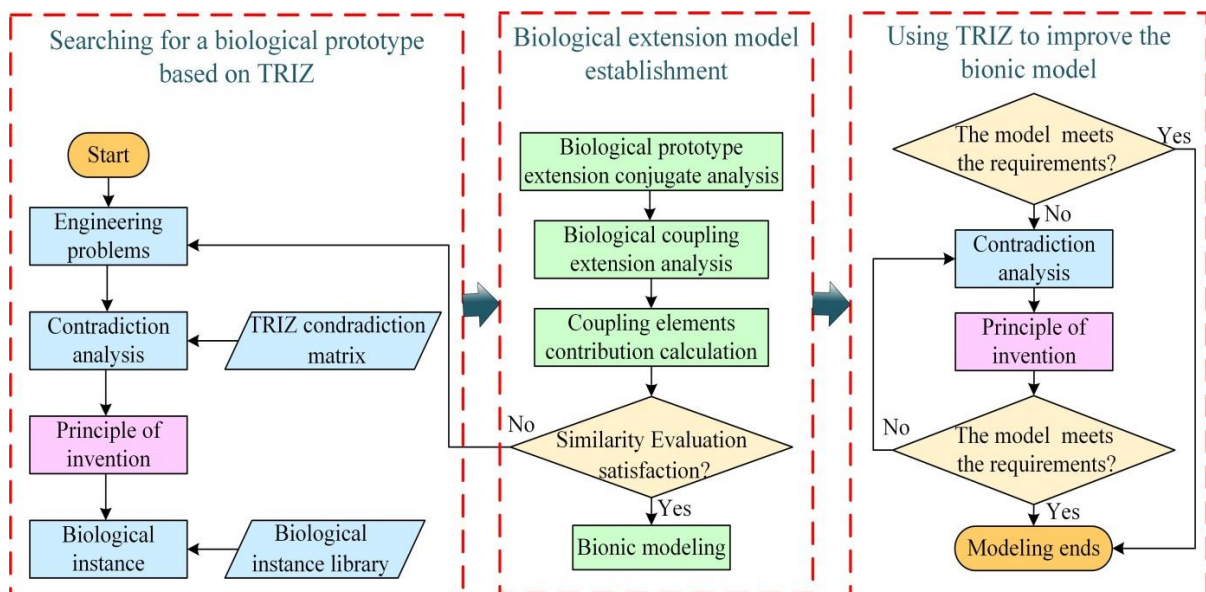


Fig. 1. Modeling method combining TRIZ theory with bionics

3 Design of Flexible Arm Based on TRIZ Theory and Bionics

3.1 Biological Prototype Search Based on TRIZ Theory

The flexible arms are lightweight, flexible, and adaptable to a variety of unstructured environments. Therefore, in the design of the flexible arm, the flexible arm is required to perform bending, stretching, torsion at first, and has a certain motion efficiency, that is, to achieve a wider spatial position in a short time; In addition, the flexible arm should have enough force to grasp the object; Furthermore, the flexible arm should be able to transform its shape to adapt to different unstructured environments. But the structure of the flexible arm should be simple and manufacturable. According to the above analysis, combined with the contradictory conflict matrix of TRIZ, the parameters to be optimized and the parameters to prevent deterioration in the flexible arm structure design were arranged, as shown in Table 1.

Table 1

Engineering parameters of the flexible arm		
Engineering parameters	Product problem description	
Parameters to be optimized	7.The volume of a moving object	Increase the range of space where the flexible arm can achieve
	9. Speed	Improve the response speed of the flexible arm
	10. Force	Increase the grasping force of the flexible arm
	25. Loss of time	Increase the movement efficiency of the flexible arm
	35. Adaptability	Enable flexible arms to adapt to various environments
Parameters to prevent deterioration	1. The weight of a moving object	Affect the movement of the flexible arm
	32. Manufacturability	Increase the manufacturing difficulty of flexible arms
	33. Operability	Increased operational difficulty
	36. Device complexity	The more functions, the more complicated the structure

According to Table 1, combined with the contradictory matrix table of TRIZ, the flexible arm contradiction matrix shown in Table 2 can be obtained, and the invention principle obtained by the contradiction matrix was used to find a solution that could be used as a practical application of the flexible arm.

In Table 2, Principle No. 1, No. 13, No. 15, No. 28, No. 29, No. 34, No. 37, etc. appeared at a higher frequency. Through analysis and comparison combined with biological instance library[5], the biology octopus arms corresponding to innovative principle No.29: the pneumatic and hydraulic structure was selected as the reference biology for the design of flexible arm. The biological cases corresponding to the innovative principle No.29 were shown in table 3.

Table 2

Contradictory conflict matrix of the flexible arm

Deterioration parameters \ Optimization parameters	1	32	33	36
	7	2,26,29,40	29,1,40	15,13,30,12
9	2,28,13,38	35,13,8,1	32,28,13,12	10,28,4,34
10	8,1,37,18	15,37,18,1	1,28,3,25	26,35 ,10,18
25	10,20,37,35	35,28,34,4	4,28,10,34	6,29
35	1,6,15,8	1,13,31	15,34,1,16	15,29 ,37,28

Table 3

Inventive Principle of No.29 Corresponding Biological Cases

Number	Inventive principle	Biological examples
No.29	Pneumatic and hydraulic structure principle	Invertebrates rely on the simple but efficient hydrostatic skeleton to maintain body shape and exercise, such as octopuses. Osmotic pressure is common in organisms, such as the cytoplasm. Osmosis is the diffusion of water or molecules through a membrane.

3.2 Biological Coupling Extension Analysis of Octopus Arms

3.2.1 Octopus Arms Extension Analysis and Model Establishment Extension conjugate analysis of octopus arms

The biological model can be divided into the hard part and the soft part: the actual composition of the biological model is called the hard part; The relationship between the biological model and its components is called the soft part [4]. The octopus arm is mainly composed of opposing transverse muscles and longitudinal muscles, so the hard part of the octopus arm can be described as

$$hr(O_m) = \begin{bmatrix} \textit{longitudinal muscle} & \textit{shape} & \textit{oval} \\ & \textit{size} & \textit{32.5cm} \\ & \textit{distribution} & \textit{evenly distribution} \end{bmatrix}$$

$$\wedge \begin{bmatrix} \textit{transverse muscle} & \textit{shape} & \textit{four - pointed star} \\ & \textit{size} & \textit{32.5cm} \\ & \textit{distribution} & \textit{radiation distribution} \end{bmatrix}$$

Soft part can be described as

$$sf(O_m) = \begin{bmatrix} \textit{transverse and longitudinal muscle relationships} & \textit{previous item} & \textit{longitudinal muscle} \\ & \textit{next item} & \textit{transverse muscle} \\ & \textit{relationship} & \textit{mutual antagonism} \\ & \textit{orientation} & \textit{interlaced} \\ & \textit{degree} & \textit{inseparable} \end{bmatrix}$$

The octopus arm extension description is as follows:

$$O_m = hr(O_m) \oplus sf(O_m)$$

1. Establishment of the octopus arm coupling element extension model

The biological coupling elements are mainly composed of the morphology, structure, material and other factors that affect the biological coupling function. The coupling elements such as morphology, structure, and material of octopus were selected for analysis.

$$M_1 = \begin{bmatrix} \textit{morphology} & \textit{shape} & \textit{approximate cylindrical} \\ & \textit{size} & \begin{bmatrix} \textit{diameter} \textit{3.5cm} \\ \textit{long} \textit{30cm} \end{bmatrix} \end{bmatrix}$$

$$M_2 = \begin{bmatrix} \textit{structure} & \textit{type} & \textit{isovolumetric} \\ & \textit{composition} & \begin{bmatrix} \textit{longitudinal muscle} \\ \textit{transverse muscle} \end{bmatrix} \\ & \textit{size} & \textit{long} \textit{32.5cm} \end{bmatrix}$$

$$M_3 = \begin{bmatrix} \textit{material} & \textit{characteristic} & \textit{soft, bouncy} \\ & \textit{tissue} & \begin{bmatrix} \textit{muscle tissue} \\ \textit{connective tissue} \end{bmatrix} \\ & \textit{ingredient} & \textit{biological protein} \end{bmatrix}$$

2. Establishment of the extension model of octopus arm coupling method

$$\begin{aligned}
 R_{12} &= \begin{bmatrix} \text{coupling method} & \text{previous item} & M_1 \\ & \text{next item} & M_2 \\ & \text{degree} & \text{closer} \\ & \text{method} & \text{combination} \\ & \text{permanence} & \text{permanence} \end{bmatrix} \\
 R_{23} &= \begin{bmatrix} \text{coupling method} & \text{previous item} & M_2 \\ & \text{next item} & M_3 \\ & \text{degree} & \text{loose} \\ & \text{method} & \text{combination} \\ & \text{permanence} & \text{permanence} \end{bmatrix} \\
 R_{13} &= \begin{bmatrix} \text{coupling method} & \text{previous item} & M_1 \\ & \text{next item} & M_3 \\ & \text{degree} & \text{close} \\ & \text{method} & \text{complex} \\ & \text{permanence} & \text{permanence} \end{bmatrix}
 \end{aligned}$$

4. Establishment of the octopus arm coupling extension model

$$B = \begin{bmatrix} \text{biological coupling} & \text{function} & \text{flexible structure} \\ & \text{coupling element} & M_1 \wedge M_2 \wedge M_3 \\ & \text{coupling method} & R_{12} \oplus R_{23} \oplus R_{13} \\ & \text{working environment} & \text{underwater} \end{bmatrix}$$

3.3 Extension Hierarchy Analysis

Combining the functional goals, the experts made pairwise comparisons and scoring on the coupling elements of the morphology, structure, and material of the octopus arm, and obtained the extension interval number judgment matrix of the coupling elements layer on the function.

Let $m_{ij}^t = (m_{ij}^{-t}, m_{ij}^{+t})$ ($i, j = 1, 2, \dots, n; t = 1, 2, \dots, T$) be the extension interval number given by the t th expert, and the calculation process was as follows:

Combining formula (1) to obtain a comprehensive extension judgment matrix M ;

$$M_{ij}^b = \frac{1}{T} \otimes (m_{ij}^1 + m_{ij}^2 + \dots + m_{ij}^T) \quad (1)$$

Solving the normalized eigenvector x^- , x^+ with a positive component corresponding to the maximum eigenvalue of M^- , M^+ ;

$$(1) \text{ Calculated by } M^- = [m_{ij}^-]_{n \times n}, M^+ = [m_{ij}^+]_{n \times n}$$

$$k = \sqrt{\frac{\sum_{j=1}^n 1}{\sum_{i=1}^n m_{ij}^+}} \quad m = \sqrt{\frac{\sum_{j=1}^n 1}{\sum_{i=1}^n m_{ij}^-}} \quad (2)$$

(2) Calculating the weight vector $S^b = (S_1^b, S_2^b, \dots, S_n^b)^T = (kx^-, mx^+)$;

(3) Calculation of coupling contribution

Calculate $V(S_i^b \geq S_j^b) (i = 1, 2, \dots, n; i \neq j)$ according to theorem 2 in the literature [6]. If

$\forall i = 1, 2, \dots, n; i \neq j, V(S_i^b \geq S_j^b) \geq 0$, then $P_j^b = 1, P_i^b = V(S_i^b \geq S_j^b) (i = 1, 2, \dots, n; i \neq j)$.

Then normalized to get $p_i = (p_1, p_2, \dots, p_n)^T$, p_1, p_2, p_3 was the contribution of each coupling element to the functional target.

The comprehensive extension judgment matrix was obtained by formula (1). The values of other variables were shown in Table 4.

$$M = \begin{bmatrix} [1,1] & [2.99,3.19] & [0.40,0.47] \\ [0.31,0.34] & [1,1] & [0.35,0.45] \\ [2.14,2.57] & [2.25,3.11] & [1,1] \end{bmatrix}$$

Table 4

Octopus arm coupling elements evaluation variable values

Variable	Value
x^-, x^+	$(0.34, 0.16, 0.51)^T, (0.31, 0.13, 0.56)^T$
k, m	0.98, 0.98
S_1^b, S_2^b, S_3^b	$[0.33, 0.16], [0.50, 0.30], [0.13, 0.55]$
p_1, p_2, p_3	0.3, 0.678, 0.023

It could be seen that the contribution of the morphological, structural and material coupling elements of the octopus arm was respectively 0.3, 0.678, 0.023. Therefore, the structural coupling element was the primary coupling element, the morphological coupling element was the secondary primary coupling element, and the material coupling element was the general coupling element.

3.3.1 Similarity Evaluation of the Biological Model and Bionic Model

The similarity calculation formula is:

$$Q = \sum_{i=1}^n (w_1 q(u_1) + w_2 q(u_2) + \dots + w_n q(u_n)) = \sum_{i=1}^n w_i q(u_i) \quad (3)$$

In equation (3), Q is similarity, w_i is weight coefficient, and $q(u_i)$ is similar coupling similarity. The weight coefficient of each characteristic coupling element was $W = [0.3, 0.678, 0.023]$. The similarity of each similarity element was $q = (0.70, 0.65, 0.4)$. After calculating, $Q = 0.66$ was got. According to the similarity evaluation criteria, the octopus arm could be used as a prototype for the hydraulically flexible arm.

3.3.2 Design of Flexible Arm

The flexible arm designed according to the octopus arm was composed of six high-elastic rubber hoses wrapped around the woven mesh, as shown in Figure 2. If high-pressure water of the same pressure was fed into the six tubes, the flexible arm would produce stretching movement; If the high-pressure water of different pressures were fed into the six tubes, the flexible arm would produce bending motion. The bending degree and bending direction of the flexible arm could be adjusted by adjusting the water pressure in each tube.

However, this structure could only be longitudinally stretched, which was not enough to meet the needs of various unstructured environments. So this structure need to be improved. We need the flexible arm to expand or contract laterally to change its shape to adapt to various unstructured environments, but couldn't destroy the stability of the structure. Refer to the contradictory conflict matrix of TRIZ to obtain the principles of invention, as shown in Table 5.

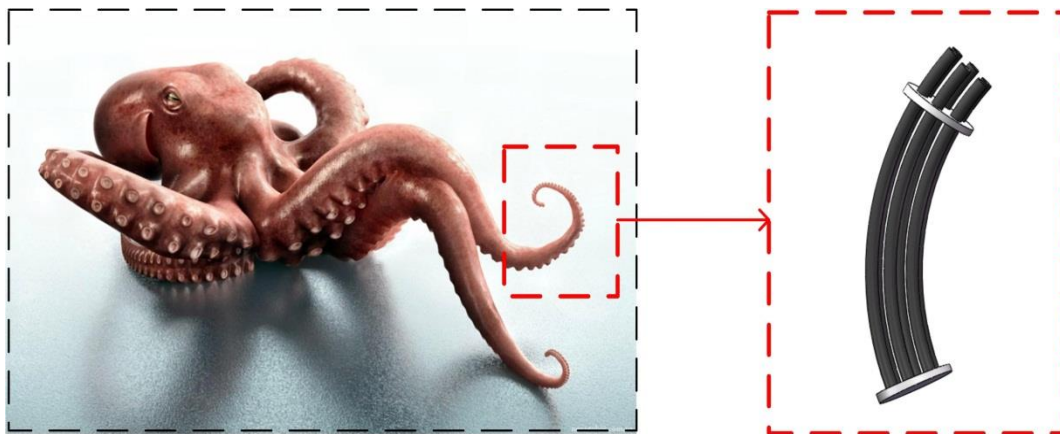


Fig.2. Water hydraulic flexible arm

Table 5

Conflict matrix

Contradiction	Stability of the structure
Shape	33,1,18,4

Through comparative analysis, we chose the principle of invention No.33: homogeneity principle as the principle of invention to solve this problem. The specific method was to connect two adjacent rubber hoses with identical high elastic rubber hoses, realizing the contraction and expansion of the flexible arm by injecting high-pressure water into the rubber hoses, as shown in Figure 3.

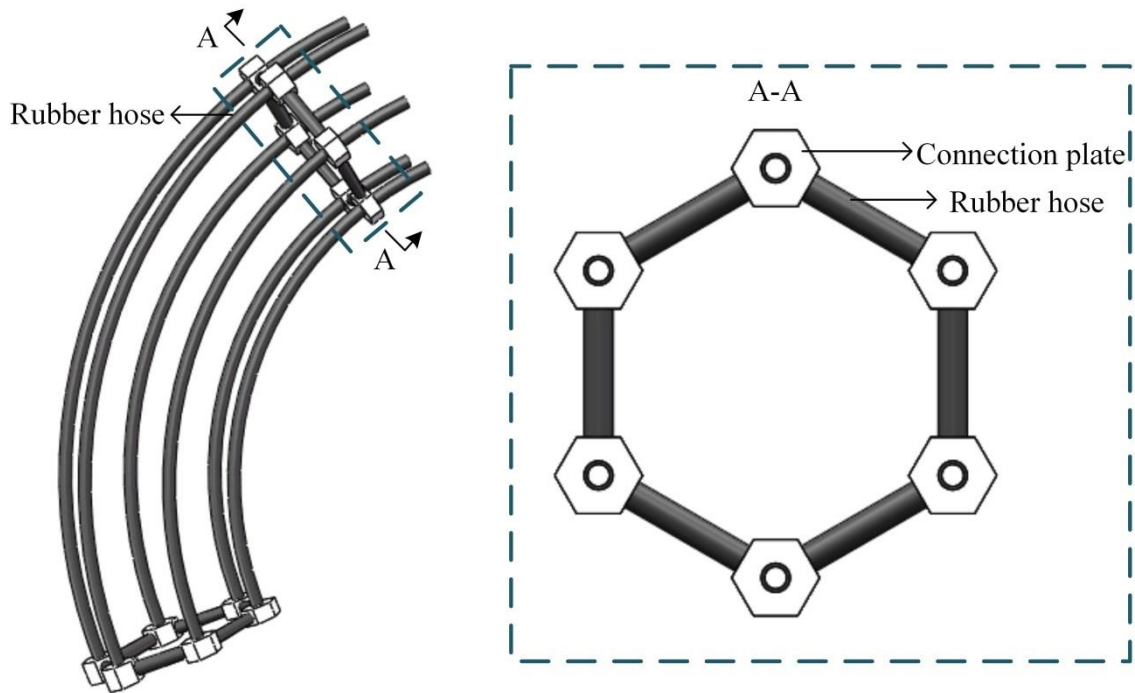


Fig.3. Variable diameter water hydraulic flexible arm

However, since the flexible arm was mostly made of soft material, the force of the flexible arm to grasp the object was weakened. So the structure need to be optimized again. We need to increase the gripping force of the flexible arm while avoiding the creation of other harmful factors to destroy the original function of the flexible arm. Refer to the contradictory conflict matrix of TRIZ again to obtain the principles of invention, as shown in Table 6.

Table 6

Conflict matrix

Contradiction	Harmful factors produced by objects
Force	13,3,36,24

Through comparative analysis, we chose the principle of invention No. 3: local quality principle as the principle of invention to solve this problem. Specifically, as shown in Figure 4, replaced three of the six flexible hoses with rigid tubes, and added the rod mechanisms to maintain the connection plates on the same plane. The connection of longitudinal rubber hoses remained the same.

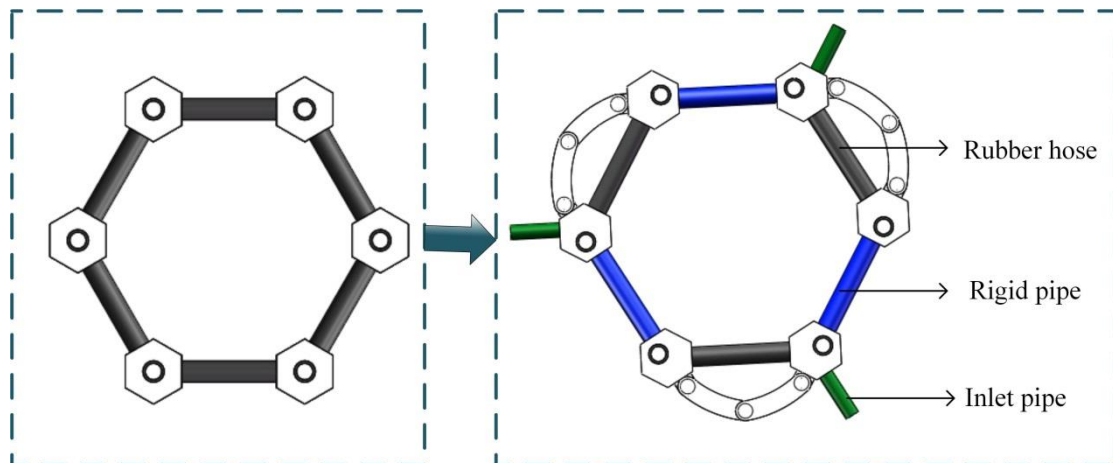


Fig.4. Variable diameter water hydraulic flexible arm

At this point, the design of the flexible arm was completed, which not only could be longitudinally stretched and bent, but also could be contracted and expanded in the lateral direction. It could adapt to various unstructured environments.

4 Conclusions

According to the advantages and disadvantages of bionics and TRIZ theory, this paper proposed an innovative design method combining the two. The conflict resolution principles in TRIZ theory were used to provide a theoretical basis for the search of biological models. At the same time, bionics provided biological references for the application of TRIZ theory. This method can provide clearer ideas for product design, reduce the difficulty of product innovation and improve the work efficiency of designers. Finally, the method was applied to the design of the flexible arm, which proved the validity and practicability of the design method.

Acknowledgments

This work was supported by the Natural Science Foundation of China under Grant 51875113, Natural Science Foundation of the Heilongjiang Province of China under Grant F2016003, Natural Science Joint Guidance Foundation of the Heilongjiang Province of China under Grant LH2019E027, "Jinshan Talent" Zhenjiang Manufacture 2025 Leading Talent Project, "Jiangyan Planning" Project in Yangzhong City. This paper is funded by the International Exchange Program of Harbin Engineering University for Innovation-oriented Talents Cultivation.

References

1. Hu Shuhua, Wang Xiuting. On Product Innovation Platform[J]. China Mechanical Engineering, 2004, 15(18): 1657-1660.
2. Vincent J F, Bogatyreva O A, Bogatyrev N R, et al. "Biomimetics: its practice and theory". Journal of the Royal Society Interface, 2006, vol. 3, # 9, pp. 471-482.
3. Xu Qihe, Ren Zhongpu, Yan Xinbo. Practical Guide to TRIZ Innovation Theory [M]. Beijing Institute of Technology Press, 2011.
4. Ren L Q. "Coupling bionics". Science Press, 2011, pp. 5-8.
5. Jian Y H. "Eco-Innovative Design Method by Integrating Bionics with TRIZ through Biological Language". Taiwan : National Cheng Kung University, 2013, pp. 49-78.

6. Gao Jie, Sheng Zhaoqi. Research on Extension Analytic Hierarchy Process[J]. Systems Engineering, 2002, 20(5): 6-11.
7. Jia Yuan, Liu Xiaomin, Chen Yuting. Product innovation integration model and its application based on TRIZ and bionic technology[J]. Journal of Engineering Design, 2014, 21(6): 522-528.

Communication

Communicating Author: yufengshu@hrbeu.edu.cn

TRIZfest 2019

September 11-14, 2019. Heilbronn, Germany

EXTENDING THE CONCEPT OF CONTRADICTIONS – TRIZ - APPLICATION IN NON-TECHNICAL / MANAGEMENT-RELATED CONTEXTS

Boris Oliver Kneisel

C 7, 1, Mannheim, 68159, Germany

Paper Classification:

- TRIZ-related methods and tools development
- Best practices, business experiences, integration with non-TRIZ methods/tools

Abstract

Current digitalization trends see many organizations launching “agilization initiatives” – these agilization initiatives/programs are subject to standard success-rate chances as known from earlier change-initiatives on rationalization in various industries. The probability of successful delivery of any type of project-related work including transition-initiatives can be stated in a range around 1/3 (or ca. 36%) [1] depending on sources, some of them reporting positive trends when de-scaling the size of projects by chunking them into digestible pieces. This range shows the presence of major risks of non-delivery of the initiative and therefore calls for pro-active risk-mitigation in order to increase chances-of-success significantly to prevent large invests (money, work-time etc.) becoming doomed-to-failure.

The assessment framework presented here was derived empirically from daily-practice to increase project success-rates by combining known input-sources from various backgrounds and re-arranging them in a new set-up to derive a new type of situational analysis framework clarifying about inherent risk-exposure allowing risk counter-measures.

Keywords: *coaching concept, situational assessment framework, TRIZ in non-technical context, Cynefin*

1 Project

The concept shown in this paper is based on experiences and empirical studies over the time-frame from 2010-2019. The concept is based on the business-goal of supporting large-scale transitions and change-management aspects of the digitalization-age.

Typical service-products to be named here are transition-concepts incl. exploration set-ups for piloting change-initiatives and all accompanying satellite-services around them (incl. training of the work-force, audits on all hierarchy levels, team-building, coaching of teams and individuals etc.).

Services alike the described above have been around for many years – many standard frameworks in project-management contain sections dealing with project risk-management. However most techniques boil-down to a risk-registry and a visualization on a risk-matrix showing a 2D-relation of impact [e.g. in EUR] vs. probability [e.g. in %] – most of these tools are static and will not dynamically adjust over the project life-cycle – which is not necessarily a mis-design but rather due to incomplete and inconsistent application and usage by implementing individuals in cases.

The proposed method however is new in its method-combination fitted and enriched to suite current digitalization-initiatives leveraging TRIZ in combination with typical methods and frameworks stemming from and resonating with current trends of “Business Agility”, where business agility is defined as really increasing measurable business-related figures that not only increase internal measures like productivity e.g. “through-put” or the related key-figure of “delivery lead-time”, but also thrive to convert improved internal power-strains into business-impact in terms of financial figures e.g. revenues & profit-margins, i.e. business agility strives for 2D-improvement on strategic effectiveness and operational efficiency in parallel.

2 TRIZ relation

The concept leverages the TRIZ-notion of “contradictions” and separation-principles extending the typical phrasing used in ARIZ (**IF...THEN...BUT...**). While TRIZ and ARIZ today are widely applied to hardware-related problem-statements with physical-goods featuring solely “*technical*” contradictions rooting in physical contradictions (e.g. mechanical- / electrical- etc. engineering challenges), describable within the complicated domain, the new concept extends towards “*socio-technical*” contradictions featuring at least one non-technical and often human factors (i.e. people and their skill-sets / experience etc.) to achieve high-performance results.

The concept takes advantage of a meaningful distinction in the English language between static conditional perspective (“**IF**”) and a time-dependent perspective (“**WHEN**”) as a connotation with respect to phrasing.

Whereas the simple and complicated domain show relationships and dependencies with linear connections, the complex domain relates to systemic thinking applying “causal-loops” as design element for modelling relationships between nodes, a new type of ARIZ-extension for business-related / non-technical / socio-technical applications is proposed to take causal-loop effects into account, then trying to insert a simplification scheme for complexity reduction proposed by phrasing:

EXACTLY THEN...*(desired system behavior & outcome)*
WHEN...*(tightened enabling boundary conditions)*
ELSE...*(other system behavior & outcome)*

Applying the new algorithmic-phrase remarkable options for complexity reduction in socio-technical systems were found that improved overall performance on the mid-term significantly.

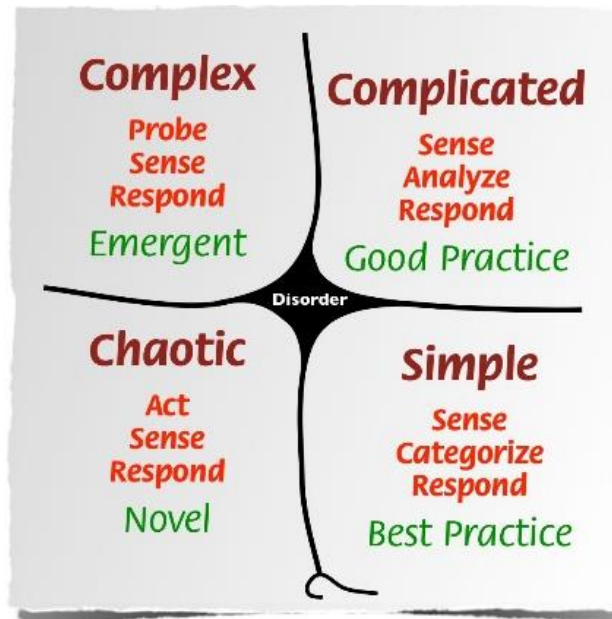


Fig. 1. The Cynefin Framework [2]

Standard TRIZ / ARIZ techniques with respect to Cynefin classification (Snowden & Boone 2007) are applicable to the so-called “ordered” domains of “simple” and “complicated” nature i.e. IF...THEN(...ELSE) relationships apply to a simple domain, while IF...THEN...BUT... applies to a complicated domain.

The new TRIZ-extension allows for structured identification of complexity-owed inherent risks of non-delivery in early project-stages and thereby ensures early mitigation. Its simple, algorithmic formatting of the template proved helpful enabling audiences to nominate risks in structured fashion.

Cynefin represents a so-called “sense-making” model – where “data precedes the framework” (Snowden, 2007) the same is true for the model-extension proposed in this paper – the suggested phrase was found in aftermath of a decent set of transition-projects incorporating each a couple of relevant example-scenarios.

The new type of algorithm-extension combines on one hand ARIZ-based thinking and phrasing, while on the other hand opening-up for TRIZ-application into the complex-domain, where it had not been possible before. So individual experience achieved by TRIZ-application in the complicated domain can now be transferred into problem-statements located in the complex-domain and after careful situational inspection undergo complexity-reduction to move back into the complicated domain, where their technical aspects may be subject of standard TRIZ / ARIZ techniques. An example for this in software-related environments is the organizational complexity reduction achieved by a new work model of the people involved supporting “agile scaling”, while in parallel the complexity-reduced set-ups allows for further automation of involved sole technical systems through introduction much cited “DevOps” approaches like “continuous integration” and “continuous deployment” for technical parts of the overall delivery model.

Thereby the no. of open issues in the overall system of a large-scale change-program to be solved is reduced and overall risk of non-delivery is decreased.

Further steps in the operating model of getting towards delivery include leverage of further TRIZ-principles like separation-principles (e.g. space, time, relation...) – as many organizations still use distributed delivery-tactics out of many hubs in near-shore and off-shore mode, the TRIZ-separation principles provide guidance with respect to backlog-allocation of work into different locations using independency-schemes connected to backlog readiness criteria, thereby saving communication efforts in day-to-day operations.

In order to illustrate the algorithmic extension, some decent example scenario is given below:

Example: Sr.Expert (=skill-bottleneck) needs to fuel 2 Agile-teams with key-knowledge

The term “Agile” needs to be briefly clarified here – in this context the term “Agile” refers to the 4 paradigms & related 12 principles of Agile Development as stated in the “Agile Manifesto” [3].

The 12 Agile principles amongst other boundaries require a team to respect some decent rules like

“The most efficient and effective method of conveying information to and within a development team is face-to-face conversation.”

Regular studies on SW-project success-rates clearly report massive quality-boost and significantly higher success-rates of SW-projects catering for Agile principles – so they should be followed. The requirement for the Sr.Expert to support multiple teams (assuming the co-location principle is to be respected) in parallel in face-to-face mode re-frames to TRIZ technical-contradiction statements:

IF a Sr.Expert is located with team1,
THEN team1 can leverage the skill,
BUT team2 can not.

IF a Sr.Expert is located with team2,
THEN team2 can leverage the skill,
BUT team1 can not.

Assuming we respect Agile principles as a mandatory boundary constraint, we can re-frame technical into physical contradictions:

The Sr.Expert needs to sit with team1 in order to provide them with knowledge
AND
the Sr.Expert needs to sit with team2 in order to provide them with knowledge

With physical-contradictions out-spoken, we apply separation principles to derive solution-ideas:

- **Separation in time**

The expert joins the teams not simultaneously, but becomes a “wanderer” (Larman & Vodde 2016) [4] being allocated to a single team in round-robin-mode on e.g. monthly or weekly basis as a temporary full-time resource to allow skill-building by

knowledge-handover to another permanent team-member. This “frequency”-based approach of cadence-related dynamic re-allocation also relates to further innovation-principles like

- **#19 periodic application** – as the regular cadence can be modeled as a continuous swinging-/bouncing movement of the wanderer between the teams

EXACTLY THEN knowhow-transfer reaches effectiveness & efficiency,
WHEN the Sr. is oscillating between a decent set of teams (here: 2) always allowed to focus temporarily on exactly one topic with no task-switching,
ELSE the knowhow-transfer will at least take much longer.

- **#13 reverse action** – the knowledge ramp-up by a permanent team-member from the Sr.Expert is driven more effectively & efficiently, when the knowledge-transfer is turned from PUSH-mode (i.e. the Sr. explaining all the time through lecture-style talks) to PULL-mode (i.e. the Sr. being quiet by default, observes jr.peoples’ activities and only intervenes, when asked to do so or in case of severe issues spottable).

EXACTLY THEN knowhow-transfer happens with max. effectiveness (i.e. at all times answering exactly the right jr. question causing current blocker of progress),

WHEN the knowledge-transfer mode is U-turned into a PULL-only mode
ELSE the knowhow-transfer will at least take much longer and will likely over-burden the info-receiving jr-party causing information-overflow by too much information being provided at a time (rate-of-intake exceeds rate-of-digesting by far)

- **#12 equivalent potential** – the wanderer is given a workplace sitting side-by-side / central to one or max. 2-4 jr. team-members (i.e. quasi-parallel coaching of jr. colleagues) instead of joining the team “just somewhere in the same office” – the office chairs are equipped with wheels to reduce hurdles of moving close to jr.people’s desk where problems are on screen-display right at the very moment of a blocking open question so frequent intimate coaching instantaneously addresses real issues and fixes concrete problems that are present in the now.

EXACTLY THEN knowhow-transfer happens at max. effectiveness & efficiency,

WHEN the Sr. is placed in close proximity to a jr.colleague enabled for specific situational coaching instead of mere artificial abstract debate,

ELSE the knowhow-transfer will at least take much longer or will be artificial and not happen at all (effect: the wanderer will never again be released from that team).

- **Separation in space**

Much of the knowledge-handover can also be achieved in so-called Agile ceremonies (aka: “events”, i.e. sessions lasting from 0.25h to ca. 2-8h with very decent purpose,

focused agenda, and clear time-boxing). The separation-in-space principle here leverages the distinct difference of the different operating-zones of the teams. This is modelled via running the overall session in parallel at the same time in the same large-room, but separating the operating-zones of the teams by assigning them different corners as their respective work-cells to ensure they are not disturbing each other while discussing to learn about topics and solving issues through face-to-face conversation.

- **#18 oscillation / frequency** – all participants are invited to the whole event as a “GROSS-slot” of e.g. 120min, additionally the agenda-structure gets chopped into smaller time-boxes of equal size of ca. 10-20min duration – these mini-events now come at a much higher frequency.

EXACTLY THEN learning happens at max. effectiveness allowing teams to get into “FLOW”-mode – balanced, i.e. challenging, yet non over-stretching
WHEN overall heartbeat is established at a high non-overburdening frequency,

ELSE the investment of the Sr.Expert’s time may result in working essentially on sub-optimal non-high-priority topics, causing just partial exploitation of the skill.

- **#16 partial (or excess) application** – the “enforced scarcity” through partial assignment of Sr.Expertise to a team of rookies forces their insight in how valuable knowledge is and enhances their motivation for structured communication and results in clear write-up of information gathered and insights won hereby – boosting all jr. learning-curve and allowing for decent “waste-control” by allocating the Sr. always to the paralleled sub-session where there is max. value-contribution to be expected through injecting the Sr. knowledge

EXACTLY THEN knowhow-transfer happens with max. effectiveness
WHILE binding relatively few precious Sr. capacity,

WHEN the Sr. is placed with the jr. sub-group massively in demand of knowledge AND working on highest-priority topics,

ELSE the investment of the Sr.Expert’s time may result in working essentially on sub-optimal non-high-priority topics, that just require that skill...

The example situations converted into TRIZ-speech indicate potentially wide applicability of the amended TRIZ/ARIZ-based algorithms proving business-extensions of TRIZ-logic from technical into socio-technical systems.

3 Results

Using techniques and practices as described above could prove to boost productivity at large socio-technical systems with multiple teams incorporating 50-100s of people to deliver high-quality product at delivery-rates reported and in cases also independently testified to reach up to factor 2x after swing-in periods of ca. 9-15 months. On achievement of described throughput increase correlated business figures like revenues saw triple-digit growth at constant profit-margins in a case proving the business agility approach really catching in with overall financial results and not only being achieved internally and then damping towards company boundaries

towards the market being eaten-up by “frictional heat” – this however requiring break-down of organizational siloes...

The situational assessment framework acts as “operationalizing” and “implementing” technique addressing risk-management in complex transition-programs at large-scale bringing the known concept of complexity-domains from theory (Cynefin-model) into practice. On the benefit side the model delivers to all coaches, project-managers, and further roles involved into leading change-initiatives a transparency-generating instance that also starts to elaborate potential solution options for risk-mitigation and appropriate risk-response activities.

The concept of ARIZ-extensions was developed and successfully piloted at various German and international customers between 2010-2019 – its applicability proved to be cross-industry – current customer-base incl. industry-verticals in Aerospace & Defence, Automotive, Industrial Engineering, Electronics & Manufacturing Industries (HVCP), Banking, Software Industries, Retail etc.

The overall achievement can be noted as a holistic concept on pro-active risk management resonating well with TRIZ-thinking as well as with paradigms stemming from Lean & Agile philosophy.

4 Conclusions

Advantages of the proposed method include early learning about risk at total transparency and an integrative design of rough-assessment as well as clear structured approach towards further detailing without interrupts. By now in projects classic risk registers tend to get replaced by various graphical forms of 2D-risk assessment – while still exploring various set-ups on different flight-levels we are happy to report further results on insights on-going...

The integrated approach proved highly successful in convincing Sr. Mgmt of various example cases to buy-in on starting to manage risks much more pro-actively, than in the past.

References

1. Standish Group, Chaos Report, 2015
2. Snowden, D.J. & Boone, M.E. “A Leader’s Framework for Decision Making”. Harvard Business Review, Nov 2007, 69-76.
3. Beck, K. et al., Manifesto for Agile Software Development (<https://agilemanifesto.org/>), 2001
4. Larman C. & Vodde, B., Large-scale Scrum: More with Less, Addison Wesley, 2016

Communication

Communicating Author: B.Kneisel@herontix.com

TRIZfest 2019

September 11-14, 2019. Heilbronn, Germany

EXTENSION OF FUNCTION MODELING TO NON-TECHNICAL SYSTEMS

Valeri Souchkov

ICG Training & Consulting, 7511KH, The Netherlands

Paper Classification:

- TRIZ-related methods and tools development

Abstract

TRIZ-based Function Analysis is one of the most widely used TRIZ techniques which provides modeling technical systems in terms of physical interactions and defining functions of the system's components based on these interactions. While the technique has proven to be successful during numerous cases, when applied to modeling social (business) or knowledge and information-based systems its use appears to be less successful due to some mistakes and confusions which result from mismatch of physical and non-physical components. The paper presents several suggestions regarding extension of Function Modeling which is a part of TRIZ-based Function Analysis to better model non-technical components.

Keywords: *Function Analysis, Function Modeling, TRIZ for non-technical applications.*

1 TRIZ-based Function Analysis

To make a difference between technical and non-technical systems, one can say that non-technical systems focus on processing knowledge and information rather than material or energy. Nevertheless, in modern days it is difficult to find a business that would not involve technology means even for completely non-technical business, for example, insurance or banking services. More and more companies use digitalization to support their processes as well as to increase both efficiency and productivity.

TRIZ-based Function Analysis (often mentioned as “*Value Engineering Analysis*”) was developed in the 1980s [1], [2] and has been applied as one of core TRIZ tools in most of TRIZ projects since.

The original version of TRIZ-Based Function Analysis demonstrated long-term success and became a “standard de facto” analytical tool in TRIZ. For example, its version developed by company GEN TRIZ is a part of MATRIZ training curricula [3] which must be learned in order to become certified in TRIZ. From time to time, further improvements of its original version are suggested [4]. Function Modeling is a core of TRIZ-based Function Analysis.

A key concept which differentiates TRIZ-based Function Analysis from other ways of function modeling is a way in which an elementary function is modeled and presented. According to [3], a function is a result of physical interaction between two components which depicts change or maintenance of a certain parameter of one of the components (a “target” component) by another component (“function carrier”).

Modern TRIZ-based Function Analysis is a universal tool which is used in following type of projects but not limited to:

- Function-Cost optimization of a product or a process (also known as “Function-Ideal Modeling” and ‘Trimming”).
- Clarification of functionality within a problem zone.
- Problems discovery and ranking.
- Anticipatory failures forecast.
- Patent circumvention.
- Function-Oriented Search.
- Disruptive innovation opportunities discovery.

While majority of applications of TRIZ-based Function Analysis have been done in engineering and technology areas dealing with processing material or energy, it is obvious that the tasks mentioned above are important for systems from other areas as well: business, social and so forth.

Below we will introduce our suggestions on updating the original TRIZ-based Function Modeling to better model non-technical components and functional interactions. Note that this paper only focuses on the aspects of function *modeling* and does not cover changes in other stages of TRIZ-based Function Analysis which remain the same as in its original version.

2 Original Function Modeling: Shortcomings

First, one must note that the shortcomings presented below have low relevance during “classical” use of Function Modeling: when it is used to model technical (engineering) systems. Most of problems emerge during business or IT applications of Function Modeling.

During recent years, there were many attempts to apply TRIZ approach to model functions in non-technical systems. Unfortunately, most of the attempts that we can find in the publications, although produced rather acceptable function models, contained the following typical mistakes:

- Incorrect definition of functions (e.g. using parameters as function targets).
- Joining several critical functions to a single function.
- Misidentifying a critical component but using it as a part of a function instead.
- Incompleteness of a component model: critical supersystem components might be missing.
- Missing critical functions.
- Messing up goals and functions.

In turn, confusion during function modeling process can often be caused by the following typical reasons:

- Too abstract descriptors of functions (e.g. “transport” vs. “move”).
- Uncertainty what to do with information flows (e.g. during control, measurement, or

- detection).
- Uncertainty how to deal with functions in digital devices (storage and processing of information).
- Uncertainty how to deal with different kinds of functions in hybrid systems (e.g. IoT).
- Uncertainty how to deal with function modeling of business, management, and organizational systems which include non-material components.

3 Proposed Extensions of Function Modeling

3.1 Tangible and Intangible Components

The suggestions below in this paper propose to extend function modeling with intangible objects as well as introduce several extra categories of tangible and intangible objects.

The Manual [3] identifies that the components of a function model must be material components: *“The components of an Engineering System are always material objects. A material object could be a substance, a field, or a combination of both. Substances, such as water, an automobile, and a toothbrush, have resting mass. On the other hand, fields, such as an electric field, magnetic field, and thermal field, do not have resting mass. Fields enable interactions between two substances.”*

Such definition is perfectly valid for physical system dealing with processing of material and energy. However, in non-technical systems intangible objects can participate in interactions and deliver functions as well. These can be such components as “price”, “advice”, “opinion”, etc. since they can affect parameters of other system’s components. Table 1 shows some types and examples of components in the extended version of Function Analysis.

Table 1

Types, Classes and Examples of components during Extended Function Analysis.

TYPE	CLASSES	EXAMPLES
Tangible system and supersystem Components	People, tools, elements of infrastructure, material documents, etc.	Postman, operator, car, scanner, receipt, planning system, warehouse, client, package, address label, cash, database, ...
Intangible system and Supersystem Components	Data, information, knowledge, decision, reaction, emotion, etc.	Price, opinion, data, data flow, specific order, (verbal) report, ...

In the original Function Modeling, we distinguish between two types of components: all components (system and supersystem) and Target component of main function. It is proposed to extend with three more types of components: 1) Intangible component, 2) Module for storing or processing data/information/knowledge, 3) Human component. Table 2 shows examples of such components and shapes proposed for better visualization of function models presented in graphics format.

Table 2

All types of components during Extended Function Analysis.

TYPE	EXAMPLE
Module for storing/processing Information/knowledge/data	Database
Immaterial component (data, information, opinion, advice, etc.)	Advice
System tangible component (from original FA)	Scanner
Super-system tangible/intangible component	Client
Target Component of Main Function (tangible/intangible)	Parcel
Human	Operator

Figure 1 shows an example how a function model can be made more detailed and expose more functions when an intangible component is introduced.

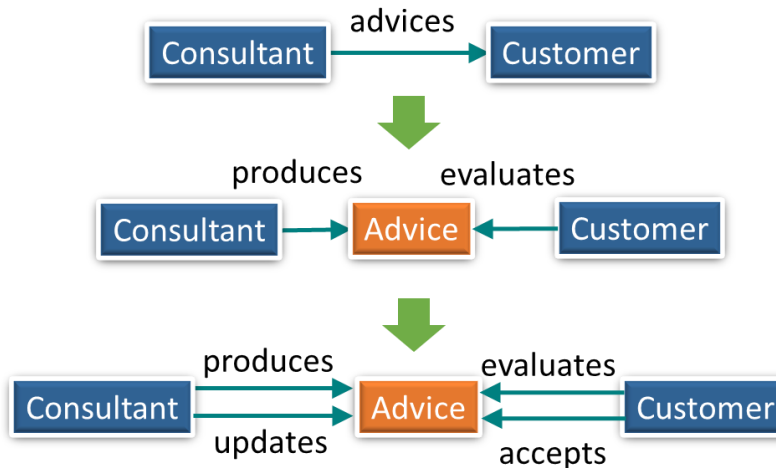


Fig. 1. Obtaining more functions due to introduction of intangible component.

3.2 Monitoring Functions

In turn, a function in [3] is defined as “an action performed by one material object to change or maintain a parameter of another material object”.

It is very strict limitation, which makes it impossible to define delivery of a function by a component if there is no change or maintenance of some parameter (or state) of the other component. For example, the function “thermal sensor measures temperature” is double invalid in the original Function Modeling: 1) It is not allowed to use parameter as function target, 2) thermal sensor neither changes nor maintains temperature. A valid function will be, for example, “air activates thermal sensor”.

Nevertheless, in non-technical systems, specifically involving humans, a certain action produced by a human operator neither changes nor maintains any parameter of another object but changes the operator’s own parameter or state as, for example, a result of observation of certain

process. Why is it important to pay attention to observation and consider it as function? In non-human systems time taken before a component changes its own state does not play important role in defining costs of operation, but in case of human operator, time spent for observation can become quite costly. In addition, there can be all sorts of problems related to the process of obtaining information which might be missed out if one does not include this function to the model, and a critical problem may be ignored at the stage of Problems Discovery of Function Analysis process. Therefore, it is proposed to add another category of functions: “passive” functions that either change or maintain a parameter (state) of a component which is a function carrier rather than function target. In that case, there are always be two inversely directed functions present between a component which initially acts as function carrier (e.g. provides observation or monitoring) and a function target which becomes a function carrier (Fig. 2)

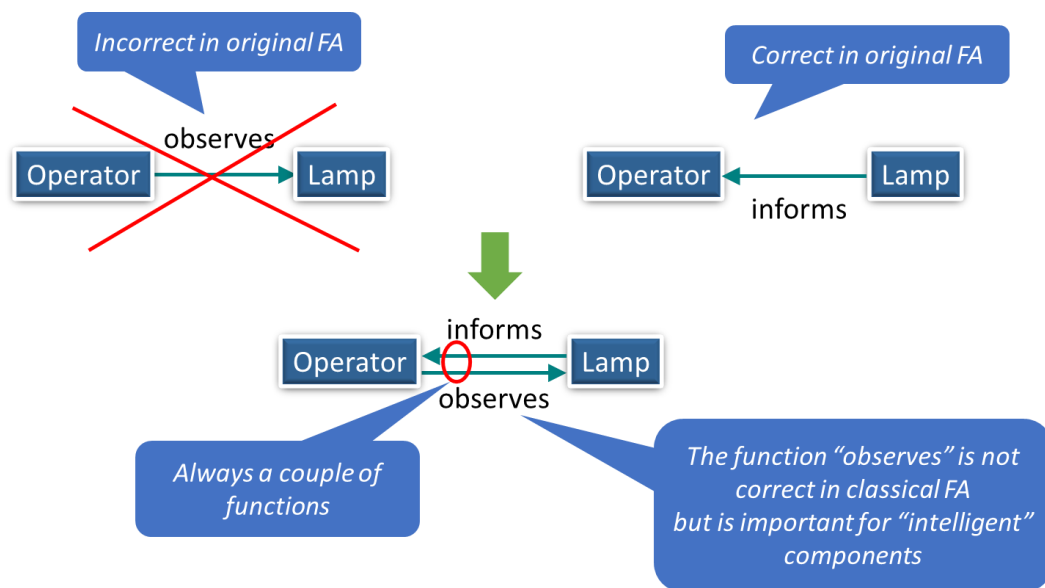


Fig. 2. Inverse active and passive functions

4 Modeling a system supporting business process

Analysis of functions in business is usually performed on the basis of modeling business processes to identify specific tasks and then decomposing these tasks to functions and sub-functions that have to be performed to deliver the tasks [5]. While there are a number of business process modeling frameworks, there are no formal rules how to present these functions. We argue that introducing a formal system-based approach can help to improve function modeling in business systems and business services. To do it, a part of a business process model is selected, and then TRIZ-based Function Analysis of a system providing and supporting this part of the business process is performed. An example of such approach is shown in Fig 3 and 4. Fig. 3 shows a part of a business process modeled with one of the most popular tools in business - BPMN (Business Process Modeling and Notation [6])

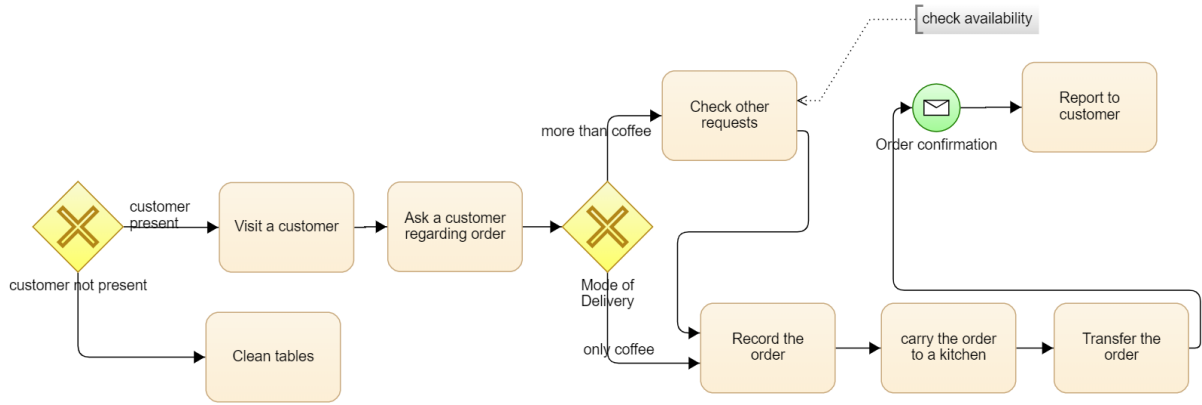


Fig. 3. A process of taking an order by a waiter in cafe modeled with BPMN

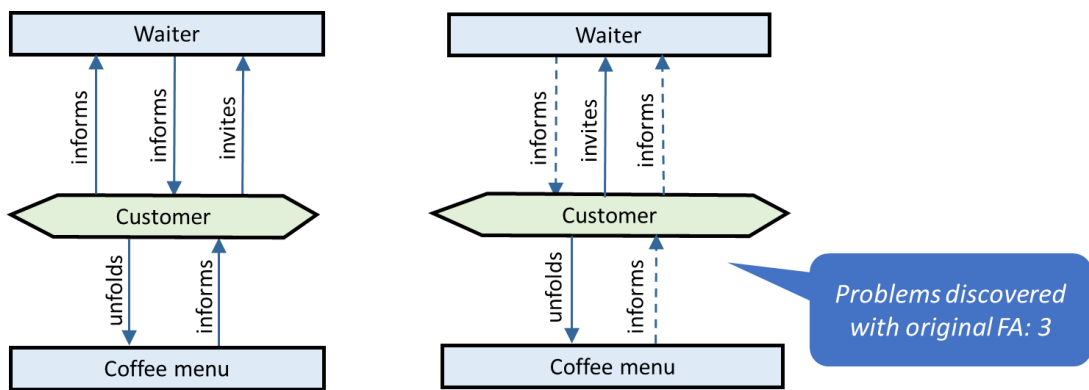


Fig. 4. Function model of taking order from a customer with original function modeling: left – model without discovered problems, right – a model with discovered problems

Once we apply extended function modeling as described above, the resulting function model includes more details which help to extract more problems (Fig. 5)

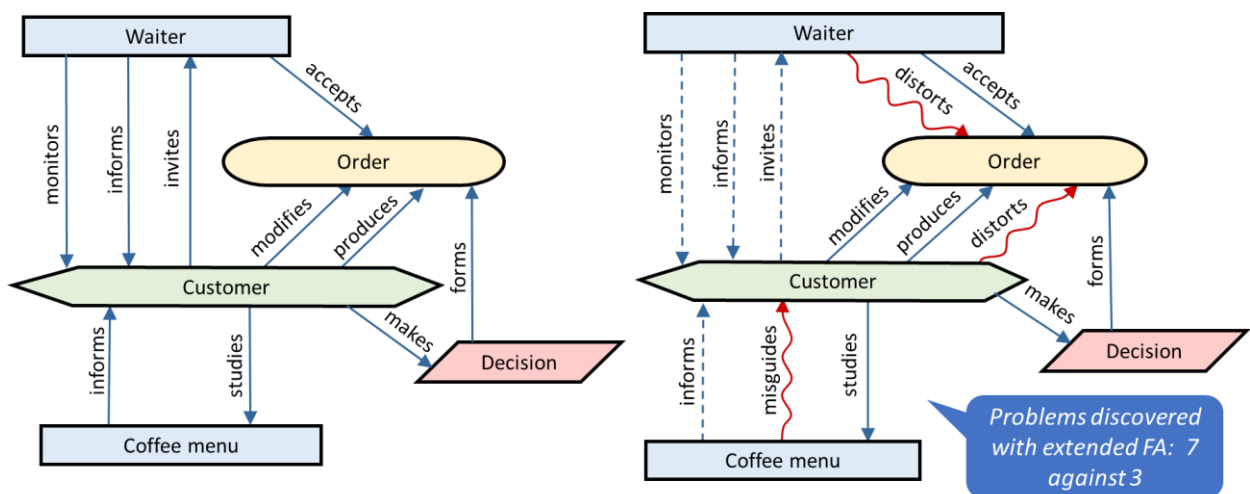


Fig. 5. Function model of taking order from a customer with extended function modeling: left – model without discovered problems, right – a model with discovered problems

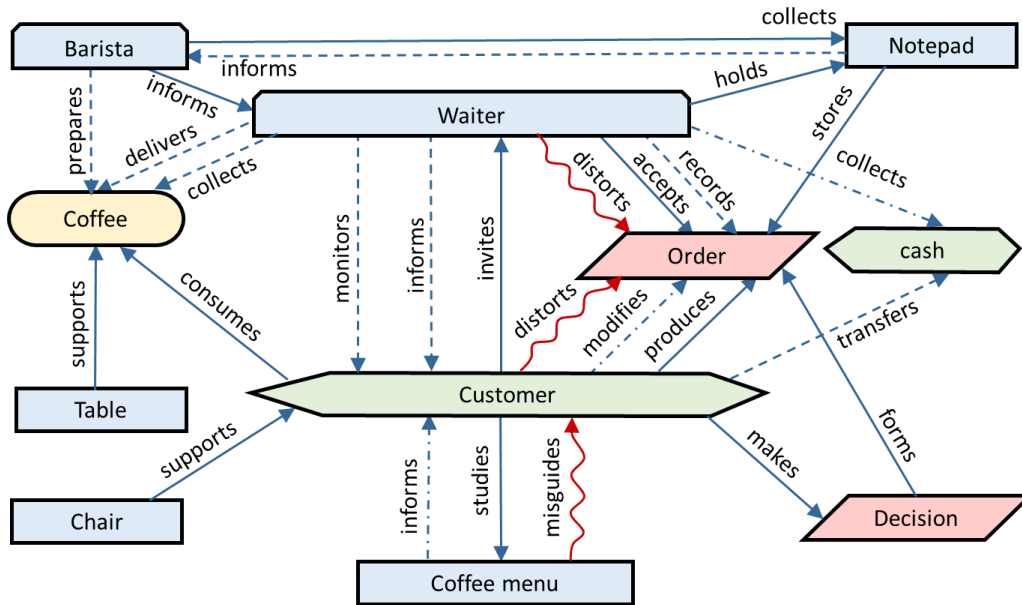


Fig. 6. Function model of taking an order and delivering the order with discovered problems.

To illustrate an Extended Function Modeling for hybrid systems, for example including information processing, a system for scanning shop’s visitors and intelligent recognition of their features was taken. The results of scanning and recognition are analysed and an analyst produces advice on the basis of report generated by the system. The function model of the system is shown in Fig. 7.

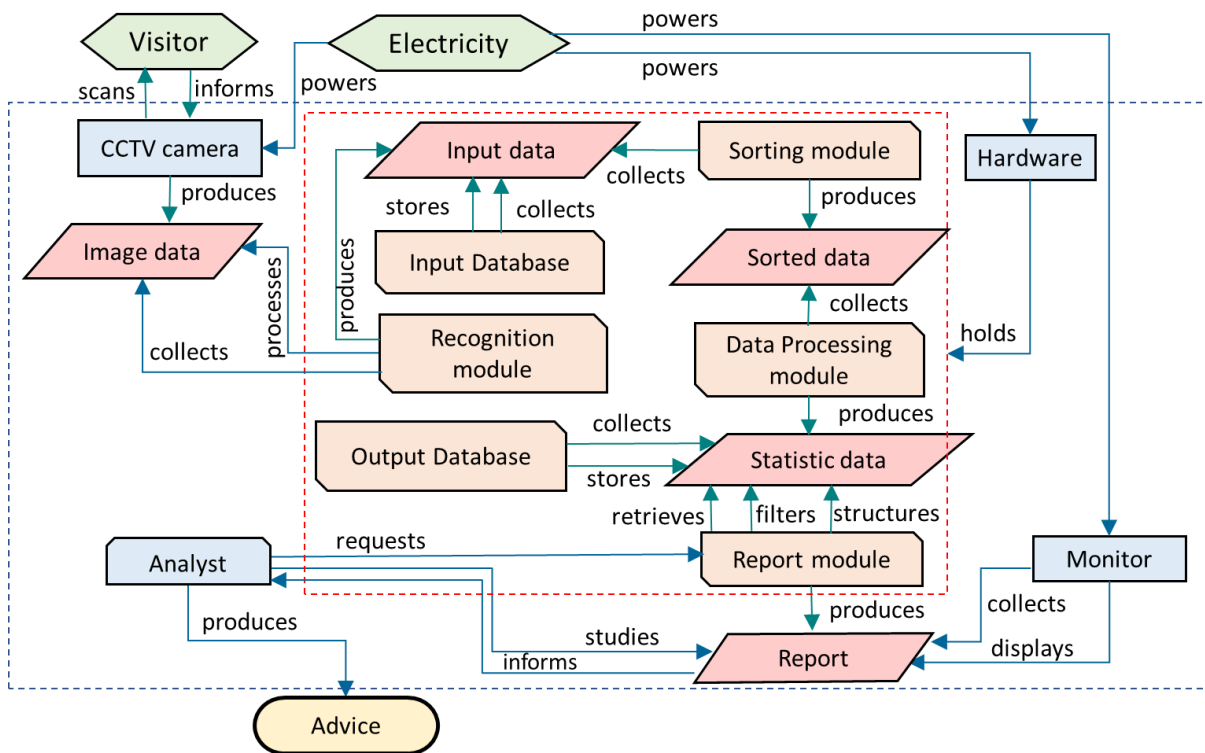


Fig. 7. Function model of a system for scanning and intelligent recognition of features of a shop’s visitors.

5 Conclusions

We believe that the additions presented above will help to improve TRIZ-based Function Analysis for non-technical and certain classes of technical systems.

Although the paper is limited to presenting the function modeling part only, the following advantages were observed during applications of the tool:

- Function/Cost model becomes more complete and accurate for knowledge and information-driven, intelligent and hybrid systems.
- New types of components expand a range of components to be included and modeled.
- Function definition for “intelligent” components is redefined.
- More complete and accurate extraction of problems.
- Extended function ranking with respect to supersystem.
- New types of costs were added to avoid missing costs.
- Better visualization of components of a Function Model.

References

1. Altshuller G.S., Zlotin B.L., Zusman A.V. Search for new Ideas: From Insight Towards Technology. Theory of Solving Inventive Problems” (Original title: Poisk Novykh Idei: Ot Ozareniya K Technologii. Teoriya I Praktika Resheniya Izobretatelskikh Zadach), Kishinev, “Kartya Molodnyavske”, 1989. (in Russian).
2. Gerasimov V.M, Litvin S.S. “Basic statements of methodology for performing function-cost analysis: Methodological recommendations”. Moscow: Inform-FSA, 1991. (in Russian).
3. MATRIZ Level 1 Training Manual, 2019. <https://matriz.org/wp-content/uploads/2019/01/Level-1-Manual-Word.pdf> . Last accessed: July 30, 2019
4. Litvin S., Feygenson N., and Feygenson O. Advanced Function Approach. Proceedings of the 10th ETRIA World TRIZ Future Conference 2010 – 3-5 November, Bergamo-Italy. pp. 79-85.
5. Grefen P. Mastering e-Business. Routledge, 2010
6. White S.A. "Business Process Modeling Notation (BPMN)," In: Business Process Management Initiative (BPMI), 3 May 2004.

Communication

Communicating Author: Valeri Souchkov, valeri@xtriz.com

TRIZfest 2019

September 11-14, 2019. Heilbronn, Germany

EVOLUTION ANALYSIS AND PREDICTION OF SHOWER

Kai Zhang, Yue Lin

IWNITALL Technology Co., Ltd, Beijing, 100000, China

Paper Classification:

- Case study

Abstract

Shower was originally a device for watering flowers, potted plants and other plants. Later, it was improved into the familiar modern shower and was very common in our life. By studying the development history of Shower, this paper tries to reveal the internal driving force of its development and check the reliability of TRIZ Forecasting [1], so as to predict the future development direction. At the same time, issues concern how to build a more scientific and logical evolutionary tree also will be discussed in this paper.

Keywords: *evolution trends, evolutionary tree, TRIZ Forecasting*

1 Project

As a frontrunner in innovation training and consulting in China, IWINTALL has been devoting to the promotion of TRIZ for many years. My main task is training and consulting on technological innovation.

According to the data from “2018-2022 China smart home industry investment situation and prospects forecast report”, the size of China's smart home market reached 60.57 billion yuan in 2016 with a year-on-year growth rate of 50.15%. As a part of smart home, smart bathroom is currently in a period of rapid growth [2].

By studying the development history of sprinklers, this paper tries to reveal the internal driving force of their development and check the reliability of TRIZ Forecasting, so as to predict their future development direction. At the same time, issues concern how to build a more scientific and logical evolutionary tree also will be discussed in this paper.

2 TRIZ relation

The first generation shower is very simple, containing only one handshower. It's the starting point for our research. In that period, the market demands were:

- a) Suitable temperature and sufficient water;
- b) Save water
- c) More comfortable shower experience

- d) These requirements are available at any time.
- e) Public awareness of good health practices has grown

2.1 *Select system/category of systems for forecasting: first generation shower*

2.2 *Perform Function Analysis at Highest Hierarchical Level*

Life stage: usage, see Fig.1.

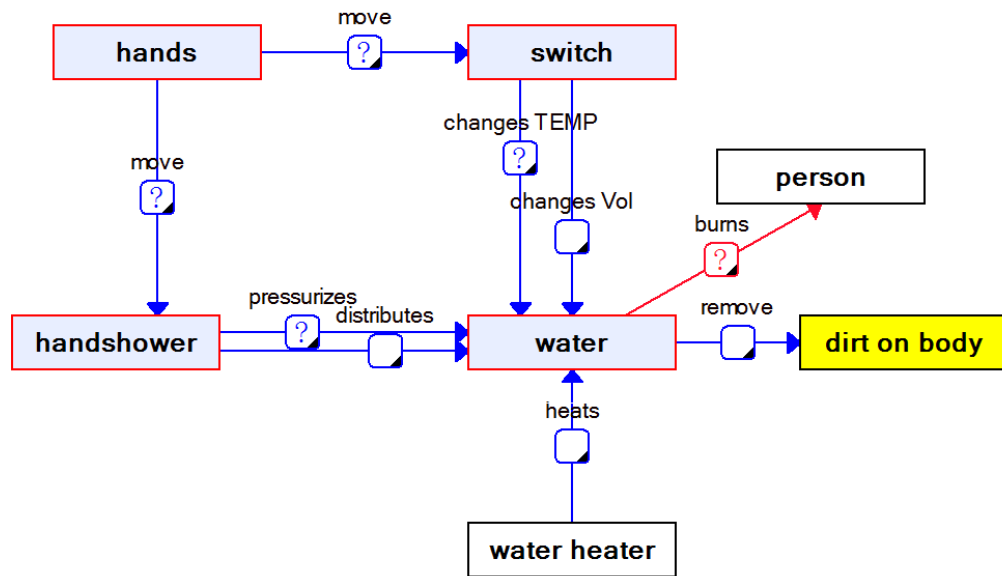


Fig.1. Function Model of shower

Identify functional disadvantages revealed by Function Analysis:

- a) The function of moving handshower is excessive
- b) The function of change temperature of water is insufficient
- c) The function of pressurizing water is insufficient
- d) The function of burning skin is harmful

2.3 *Identify Main Parameters of Value (MPVs)*

Consider functional disadvantages revealed by Function Analysis (e.g., harmful functions or insufficiently performed useful functions) as unsatisfied Main Parameters of Value (MPVs) for future improvement:

The following MPVs can be identified:

- a) Convenience of moving handshower
- b) Controllability of water regulating
- c) Controllability of water spaying
- d) Efficiency of dirt removal in water

2.4 Perform S-curve based Benchmarking

Compared with bathtub, it is obvious that Shower is irreplaceable as a convenient and economical way to wash out the dirt on skin. Shower had survived to this day without changing its main function.

2.5 Perform Function Analysis (see Fig.2) and Flow Analysis (see Fig.3) of the best system to identify its disadvantages

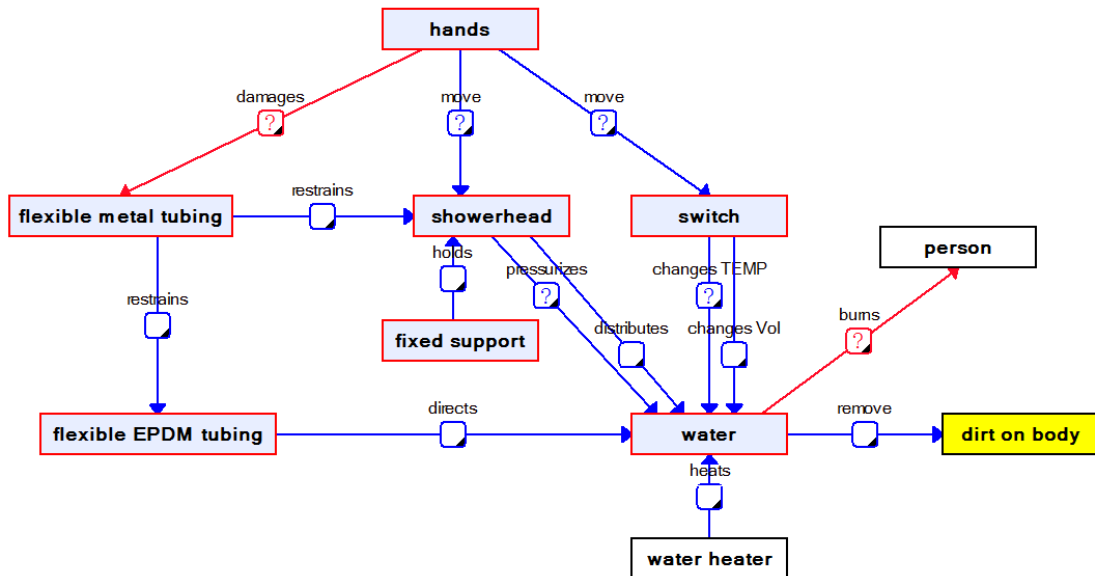


Fig.2. Function Model of shower in detail

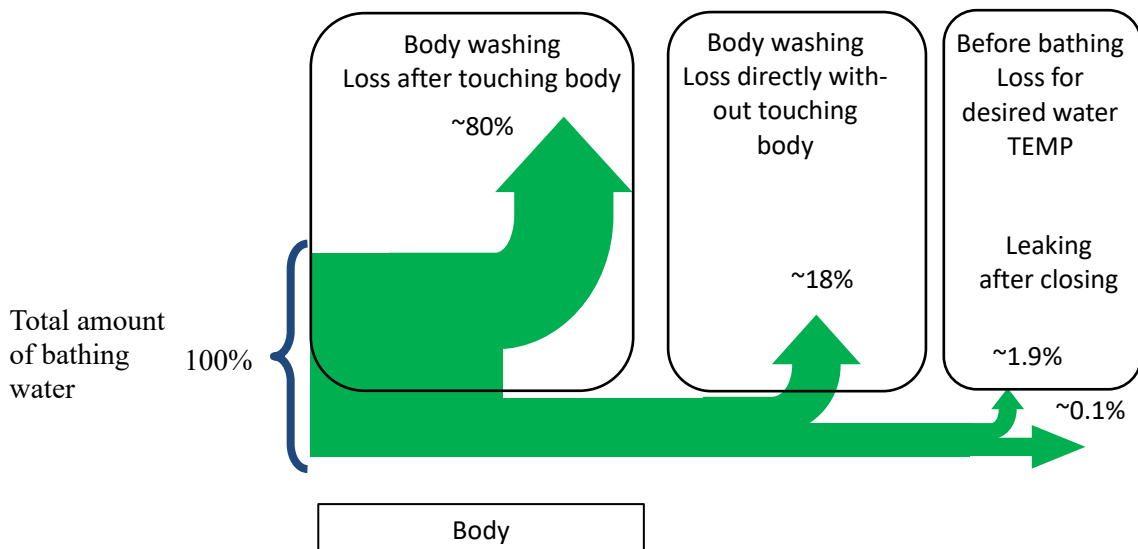


Fig.3. Flow Model of shower

2.6 Apply CECA to identify prognostic Key Problems (Fragment)

Choose initial disadvantage as Water Wasting. Conduct CECA analysis, see Fig.4.

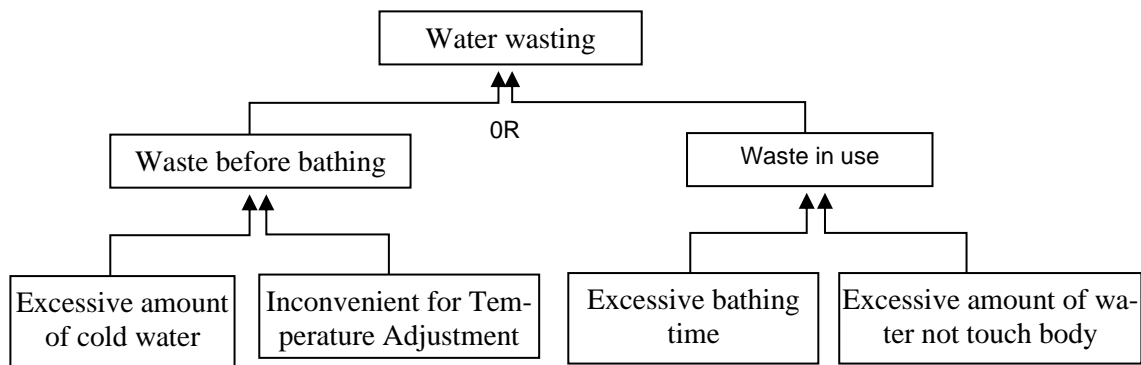


Fig.4. CECA Model

Key Disadvantage can be identified as ‘Inconvenient for Temperature Adjustment’, ‘Excessive bathing time’ and ‘Excessive amount of water not touch body’.

So in the long run, shower is developed in order to solve these Key Disadvantages. We can summarize as follows:

In order to save wasted water, Shower head with sensor appears in the market. , see Fig.5. Once the person leaves the shower, the shower automatically stops the flow of water [3]



Fig.5. shower head with sensor

In order to solve excessive use of water, shower with the function of water volume alerting appeared, see Fig.6.



Fig.6. shower with water volume alerting

In order to make water temperature adjustment more convenient, shower with constant temperature switch appeared, see Fig.7.

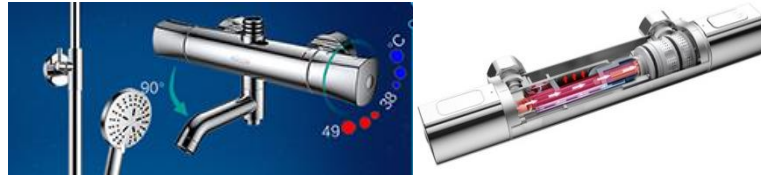


Fig.7. Constant temperature switch

As for insufficient pressure, there are various types of pressurized shower, see Fig.8.



Fig.8. Pressurized shower

As for bad water quality, shower with purifying water function appeared, see Fig.9.



Fig.9. Shower with purifying water function

For the insufficient cover area of the shower, we can formulate it as Engineering Contradiction, see Table 1.

Table 1

Engineering Contradiction in cover area

if	cover area is big,
then	overall coverage of the body can be improved
but	pressure of water outlet is reduced

Identifying the Improving and Worsening Parameters:

- a) Improving parameter: area of stationary object
- b) Worsening parameter: force

According to Altshuller’s Matrix, The recommended inventive principles are : 1.segmentation, 18.using mechanical vibration, 35.change physical or chemical properties and 36.using phase transition.

Apply segmentation, shower head with smaller holes has been developed, see Fig.10.



Fig.10. shower head with tiny hole

As for principle of using mechanical vibration, Fashionable pulse supercharged shower head belong to this kind, see Fig.11.



Fig.11. Big shower head with pulse pressure-charging

2.7 Perform TESE Analysis to identify prognostic Key Problems and develop related idea

Trend of Increasing Coordination

Different ways of spraying water, shower is more coordinated with the human body, almost all imaginable ways and angles have been realized, see Fig.12.



Fig.12. Increasing Coordination of spraying water

In addition, shower has been coordinated with a variety of user needs. This required products that can be instantly customized by many parameters for various individuals.

Fig.13 below represents trend of increasing coordination in other ways.

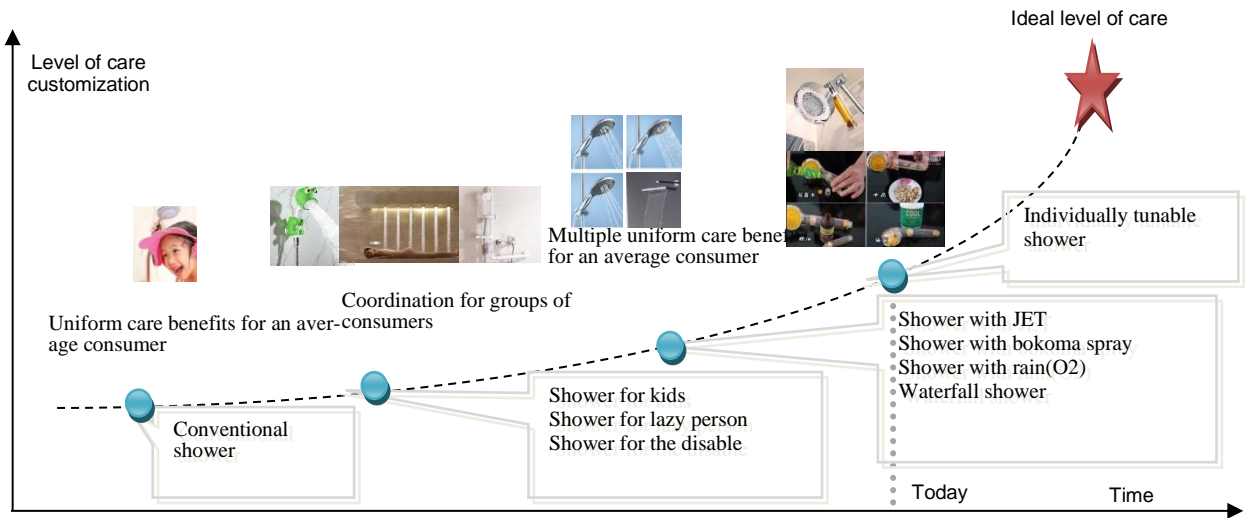


Fig.13. Increasing Coordination of shower

Key Problem: How to increase individualization of shower?

Trend of Transition to the Supersystem, see Fig.14.

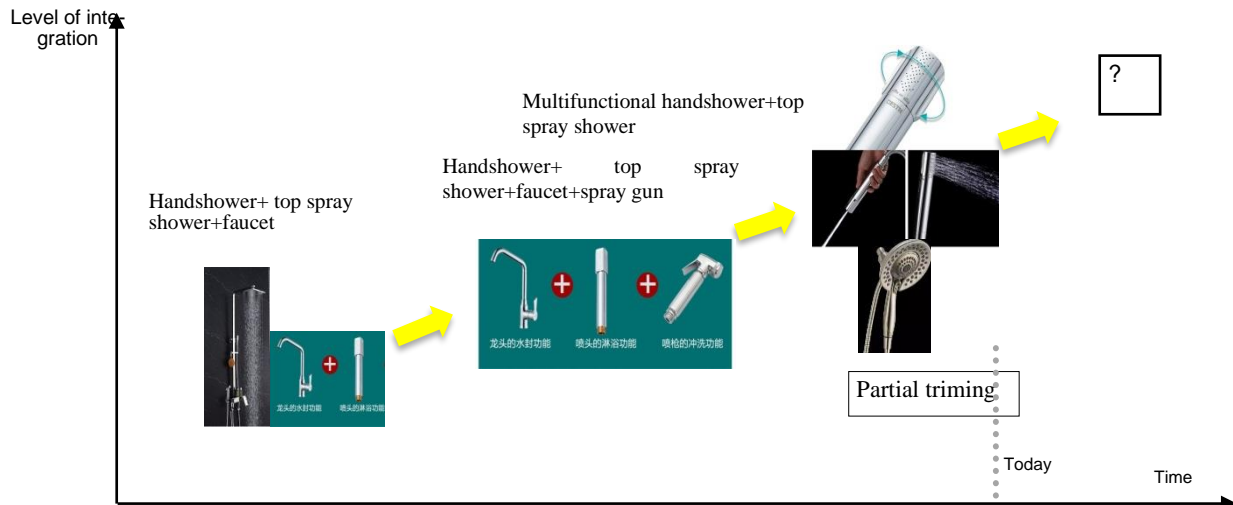


Fig.14. Transition to the Supersystem of shower

Trend of Increasing Controllability, Subtrend 1 – Increase Level of Control

Increase Level of Control, See Fig.15.

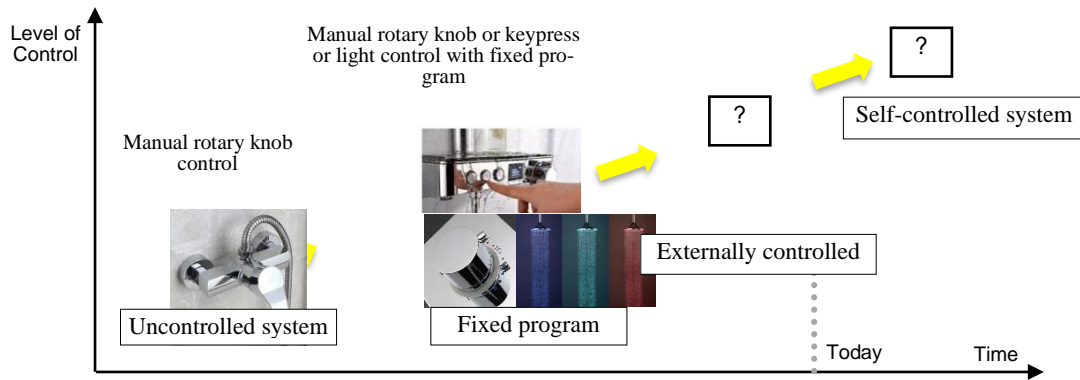
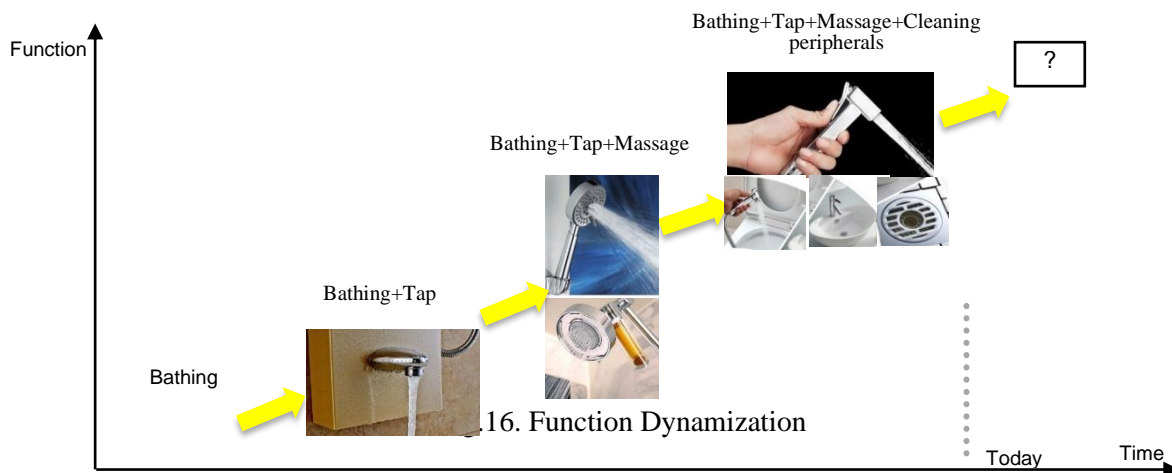


Fig.15. Increase Level of Control

Trend of Increasing Dynamization: Subtrend 3 – Function Dynamization, see Fig.16.



Trend of Transition to the Supersystem:

2.7.1 Subtrend 3 – Deeper integration between cold& hot water switch, see Fig.17.



Fig.17. Deeper integration between Cold& hot water switch

2.7.1.1 Subtrend 3 – Deeper integration between outlet switch and cold& hot water switch, see Fig.18.

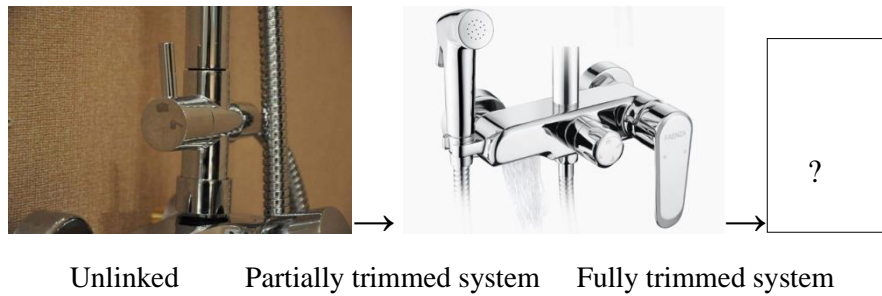


Fig.18. Deeper integration between outlet switch and cold& hot water switch

2.7.2 Subtrend 3 – Deeper integration between shower and stand, see Fig.19.

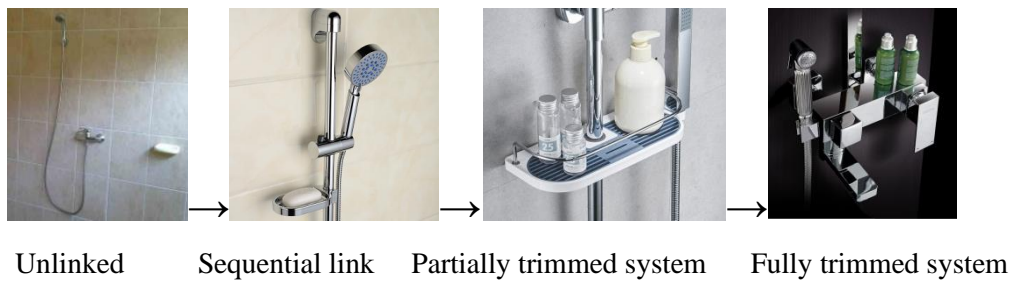


Fig.19. Deeper integration between shower and stand

2.7.3 Subtrend 3 – Deeper integration between shower and shower gel and others

Deeper integration between shower, shower gel and others, see Fig.20.

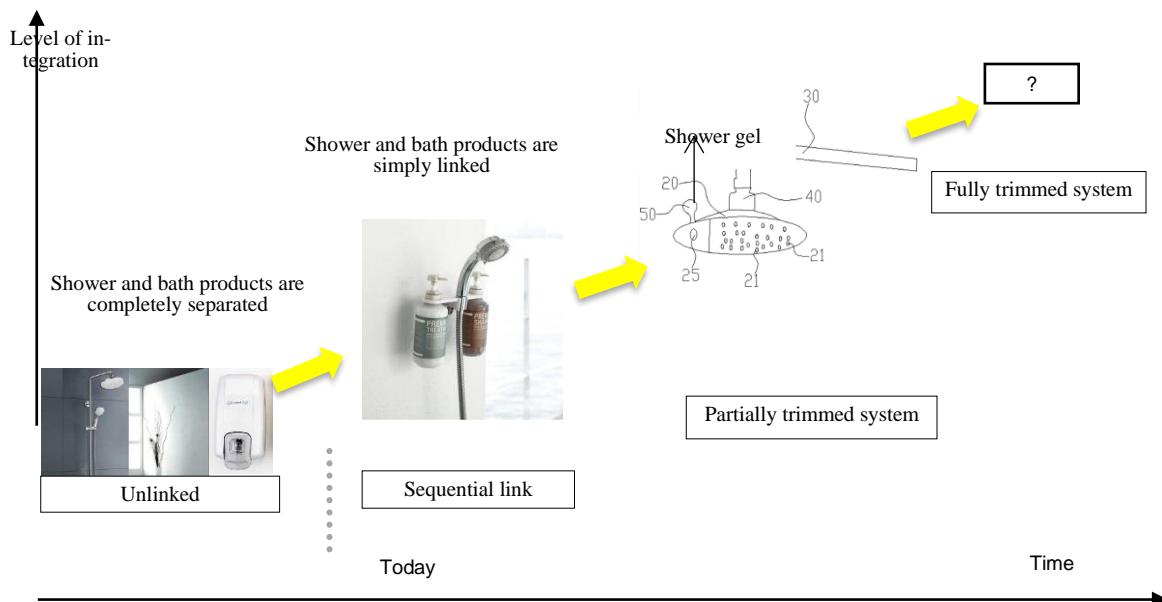


Fig.20. Deeper integration between shower and shower gel

2.7.4 The Trend of shower transition to other Supersystem

Shower head is integrated with lamp, see Fig.21.



Fig.21. Shower head with lamp

Shower is integrated with washer, see Fig.22.



Fig.22. Shower with washer

Shower is integrated with water heater, see Fig.23.



Fig.23. Shower with water heater

Shower is integrated with bathtub, see Fig.24.



Fig.24. Bathtub with shower

Shower is integrated with shower room, see Fig.25.

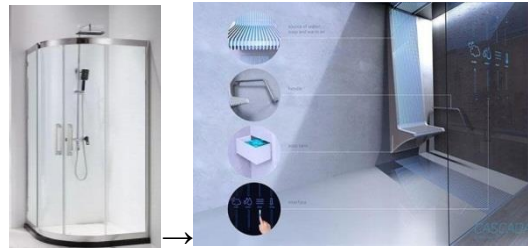


Fig.25. Smart shower room

Shower is integrated with audio, bluetooth, see Fig.26.



Fig.26. Shower with audio, bluetooth

3 Build integrated forecast in the form of new product platform

According to shower industry analysis from 2016 to 2021 released by China Report Hall and the guidance report of the 13th five-year development plan, it is believed that in the future, wisdom + health will become the strategic direction of the intelligent space of the shower industry [4].

Base on the trend of increasing controllability, along the path of uncontrolled system → fixed program → externally controlled → self-controlled system, for the Water Temperature Adjustment, we could predict that: Shower may detect current air temperature both indoor and outdoors and so on, and automatically adjust most suitable water temperature by Intelligent induction regulation, So we no longer need to manually adjust the temperature of winter and summer [5]. At the same time, products with automatic control of body condition (cleaning, fragrance, skin care, etc.) and automatic scrubbing and spraying various body management products are to be expected.

Base on the trend of transition to other supersystem, more elements will be further integrated into batch process, such as more modern SPA elements will be added, like massage, skin care and so on. Bathing will give five senses of the human body a full range of relaxation, such as hearing (efficacy music, natural sound), touch, smell (fragrance), vision (natural or imitation of natural landscape) and so on, to achieve total relaxation of body, heart, and spirit .In addition, the shower process can be connected to the Internet of things, like bluetooth, audio, ventilation system, bath heater and other systems, and enhanced with artificial intelligence.

The integration of shower and bathtub or shower room brings more development resources for product development. It is easier to realize the above needs on such products. However, due to the limitation of urban personal shower space, the shower can also enhance the above functions. New problems such as reducing shower noise will be considered.

4 Conclusions

We can logically reveal the internal driving force of system's development and predict future development direction. TRIZ Forecasting not only predicts the directions in which a technology will evolve, but also delivers specific design solutions.

References

1. Serge Ikoenko, Advanced TRIZ Training (MATRIZ Level 3) [R], GENS, MATRIZ Beijing Pera China Training Center, 2018
2. 2018-2022 China smart home industry investment situation and prospects forecast report, <http://www.chinahyyj.com/yanjiubaogao/IT/QiTa/660114.html>
3. Take a bath with these types of showers, smart home, <http://www.shejipi.com/125048.html>
4. Analysis on the development trend of China's shower industry in 2017, <http://www.chinabgao.com/k/huasa/25590.html>
5. What is the intelligent shower room that makes life square facet more convenient. Home nuclear optimal, <https://www.jiahe.com/topic/295343.html>

Communication

Communicating Author: karl.zhang@iwintall.com

TRIZfest 2019

September 11-14, 2019. Heilbronn, Germany

EXPERIENCE OF LARGE HOLDING COMPANIES: INTERNAL TRIZ TRAINERS EDUCATION

Elena V. Redkolis

Scientific and Industrial Consultants LLC, Moscow, 121096, Russia

Paper Classification:

- Best practices, business experiences, integration with non-TRIZ methods/tools

Abstract

The paper presents the results of experience with in-depth training TRIZ course in the amount of 400 academic hours for employees of companies in the metallurgical and energy industries. The course goals are to study the TRIZ methodology, to transfer methodological skills, and to solve the real production problems with the subsequent launching and implementing of projects at the enterprises.

Keywords: *analytical TRIZ tools, internal TRIZ trainer, production problems, corporation, predictive TRIZ tools, TRIZ tools for problem solving, TRIZ trainer, TRIZ in corporations, TRIZ projects, training module.*

1 Introduction

The Institute of internal TRIZ trainers education was initiated at several large Russian companies about one year ago. The training programs, significantly different from the experience presented in [1–6], have been started for line staff, mid-level staff and top management of the companies in context of this event.

In accordance with the regulated standards, an internal TRIZ trainer is a corporate employee of an enterprise or some divisions of the companies, who is engaged in part-time basic TRIZ training of other employees of various departments and enterprises of the companies. He reports to the head of the department in which he works on a permanent basis and is not a staff member of TRIZ Front Office.

The goals of the Institute of internal TRIZ trainer education in companies are:

- identification of companies' most perspective engineering and technical staff among those who were trained in the short-term 9-day TRIZ practical sessions;
- organization of permanent corporate system of training in TRIZ;
- methodical promotion of the use of TRIZ tools by employees of the companies as part of processes of production problem solving and realization of projects;
- popularization of TRIZ as effective methodology for identification and production problem solving in the Companies perimeter.

The training programs were implemented for two years. The advantages and disadvantages of teaching approaches are analyzed below.

2 Internal TRIZ Trainers Education Process

2.1 Competitive Selection

TRIZ Front Office is a permanent division in a company structure which defines the necessity of internal TRIZ trainers.

In order to ensure quality training, a group of no more than 18 employees (hereinafter referred to as students) is trained during one cycle. Each of the students of the training course solves a real production problem agreed by the management of the enterprise and TRIZ Front Office.

The companies consist of dozens of enterprises located in different cities of Russia, so the need for training of internal TRIZ trainers is large enough. In addition, the competitive selection has established itself as a best way of ensuring the involvement and motivation of employees.

Interviewing and testing candidates to reveal educational potential are the obligatory stages of the competitive selection. Certified TRIZ professionals conduct job interviews at personal meeting or by video conferencing. The selection stages include:

- creation of the list of candidates;
- testing candidates to evaluate their professional and communicative skills and to indicate the potential of their professional development;
- interviewing the candidates;
- overall review and creating a list of internal trainers for further TRIZ education.

Based on the results of competitive selection, candidates are added to the list of educational program students. This program includes four educational modules on out-of-service training during two weeks for each.

2.2 Course Structure

400-hour training format is sufficient for the education of the trainer "turnkey" (without the need for further educating), which:

- has mastered all the basic tools of classical and modern TRIZ;
- has completed in practice one real project, without assistance taking into account the specifics of his enterprise;
- has gained the skills to manage more than 4 real projects owned by other course students.

The goals and the content of the modules of educational program are presented below.

Table 1

Content of the Educational Program for Internal Trainers

Module name	Module content
<p>#1 <i>Introductory module.</i> The goal is to study TRIZ methodology and features of its application for solving of real production problems.</p>	<p>Day 1. Brief history of TRIZ; Basic ideas and definitions; Psychological inertia removing techniques: Brainstorming; Introduction with the TRIZ tools; Appointment of problem solving and analytical TRIZ tools; Identification and formulation of contradictions.</p> <p>Day 2. Psychological inertia removal techniques: Method of focal objects; Methods for elimination of contradictions; Determination of the conflict center; Operational zone; Operational time.</p> <p>Day 3. Psychological inertia removing techniques: Morphological analysis; 40 Inventive Principles; Matrix for choosing inventive principles.</p> <p>Day 4. System operator (9-screen pattern) for identification of technical system (TS) requirements; Stakeholders analysis; Main Parameters of Value (MPV) analysis.</p> <p>Day 5. Ideality; Ideal Final Result (IFR); Typical mistakes in the formulation of contradictions; Resources.</p> <p>Day 6. Cause-and-effect (CE) analysis: Operational zones correction.</p> <p>Day 7. Functional analysis: formation of interaction model; Laws of systems evolution: General Idea; Law of system parts completeness.</p> <p>Day 8. Functional Ideal Modeling: Basic Idea, its link with IFR; Index of physical effects.</p> <p>Day 9. Flows analysis: Types and disadvantages of flows; Diversionary analysis; Function-oriented search: Basic Ideas.</p> <p>Day 10. The use of TRIZ for forecasting: System operator (9-screen pattern), Limits of systems evolution; Law of S-shaped system evolution.</p>
<p>#2 <i>Analytic module.</i> The goal is to practically apply the analytic TRIZ tools.</p>	<p>Day 1. Identification and elimination of contradictions; Formulation of the ultimate goal and resource use.</p> <p>Day 2. Identification, analysis and integration of alternative systems; Benchmarking.</p> <p>Day 3. Cause-and-effect analysis: Complementary operator (formulation of a problem through effect elimination with inevitable existence of its cause).</p> <p>Day 4. Work with information and patent databases.</p> <p>Day 5. Functional analysis: parametric analysis, function ranking and assignment of tasks.</p> <p>Day 6. Functional Ideal Modeling (in the super- and sub-systems); Work</p>

Module name	Module content
	<p>with the “TechOptimizer” software.</p> <p>Day 7. Flows analysis: Analysis based on the component interaction model, Analysis with Sankey diagram, Tasks formulation.</p> <p>Day 8. Analysis of the system life stage with the help of S-curve; Key stages and its specific aspects; Recommendations for different systems which are located at different stages.</p> <p>Day 9. Creating the roadmaps for the analytical phase of the different types of projects; Choice of the problem solving TRIZ tools.</p> <p>Day 10. Special aspects of the teams activity management during analytic phase of the TRIZ project.</p>
<p><i>#3 Predictive and solving module.</i></p> <p>The goal is to practically apply the predictive and problem solving TRIZ tools.</p>	<p>Day 1. Identification of contradictions after the use of different analysis TRIZ tools (MPV analysis, CE analysis, functional analysis, flows analysis); 40 Inventive Principles; Matrix for choosing inventive principles.</p> <p>Day 2. Algorithm of inventive problems solving (aka “ARIZ Algorithm”).</p> <p>Day 3. Practical use of predictive TRIZ tools and tools for new product creation.</p> <p>Day 4. Laws of systems evolution: Law of ideality increase, Law of human displacement out of TS.</p> <p>Day 5. Laws of systems evolution: Law of effectiveness increase of using flows, Law of sub-systems development disparity, Law of dynamics increase.</p> <p>Day 6. Laws of systems evolution: Law of increase of compressibility, Law of transition to super-system; Function-oriented search: special aspects, practical use.</p> <p>Day 7. Laws of systems evolution: Law of coherence increase, Law of controllability increase.</p> <p>Day 8. System operator (9-screen pattern) for identification of some systems development trends.</p> <p>Day 9. Preparing the students’ presentations on their real production problems (as a result of problem solving its during ##1–3 Modules).</p> <p>Day 10. Critical design review by TOP managers of companies.</p>
<p><i>#4 Project management module.</i></p> <p>The goal is to study the special aspects of the educational</p>	<p>Day 1. Types of projects and their special aspects.</p> <p>Day 2. Creating the roadmaps for the solving and forecasting phases of different types of projects.</p> <p>Day 3. Special aspects of the teams activity management during solving and forecasting phases of a TRIZ project.</p>

Module name	Module content
process organization and practical application of TRIZ tools.	<p>Day 4. Providing control of project implementation: general principles. Practical cases.</p> <p>Day 5. Features of the organization for the quality assurance control of the implementation activities.</p> <p>Day 6. Features of the organization for the time control during the implementation of TRIZ projects.</p> <p>Day 7. Detailed analysis of complex cases which were implemented earlier and their quality estimate.</p> <p>Day 8. Features of the organization for combining educational process with analytic and problem solving stages of the real production problems.</p> <p>Day 9. Preparing short educational course for TRIZ training in 9-days format.</p> <p>Day 10. Presentations of projects by students. Summing up the results of training.</p>

At the end of the third module, the project presentations by the students are examined to check understanding their level and TRIZ tools usage skills. After the fourth module, the students present their final projects and the short educational course for TRIZ training in 9-days format. This short course consists of three 3-days modules and has the goal to check pedagogical skills, audience management skills, and knowledge transfer skills regarding TRIZ tools which students studied during the course.

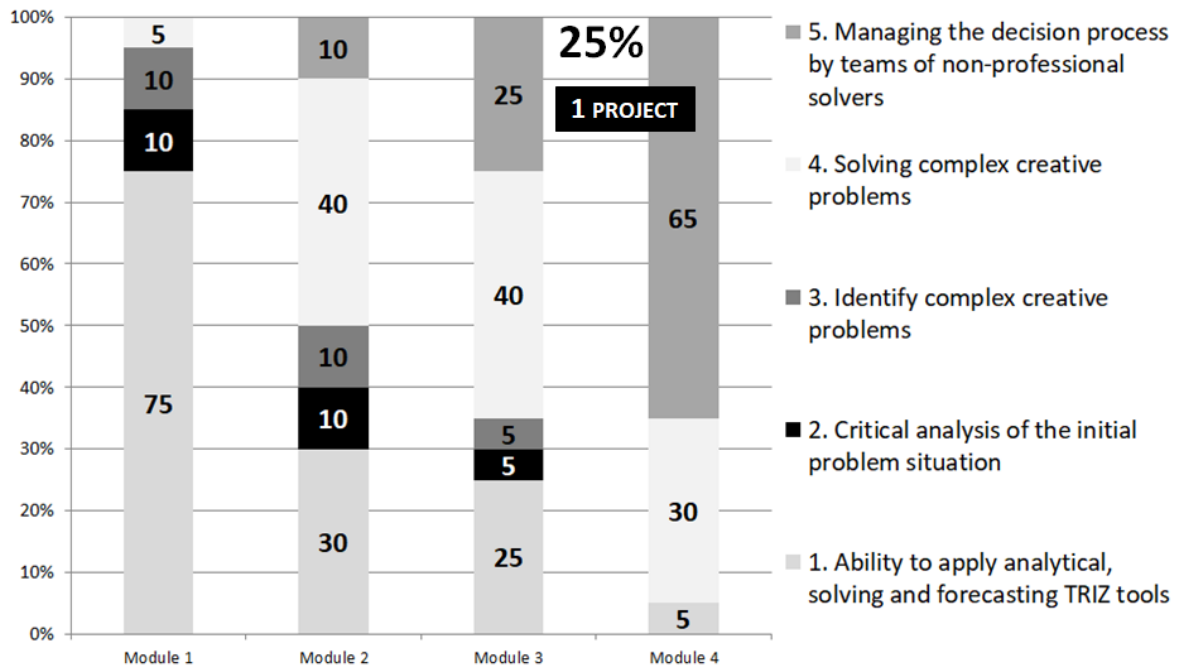


Fig. 1. The course schedule for the internal trainers group

(400 acad. hrs., including 136 acad. hrs. for the study of TRIZ methodology), Flow 1 (2018)

Based on the results of the first educational flow (consisting of two groups, total quantity is 36 people in each) of 2018, the conclusion was made about low effectiveness of work with only one real production problem by every student during 400-academic hours period. The decision was made to increase the educational program intensity for possibility to prepare two project by each student after the end of training.

The study of the TRIZ methodology takes 34% (136 acad. hrs.) of the total make-ready time (it is 75%, 30%, 25% and 5% of the time from 1-4 modules on the Fig. 1, respectively). All the while, each student spends 25% of the total time for creation of the solution concept within its real production problem. The rest of the time is dedicated to advancing the skills of TRIZ tools application within the training tasks. Not only “textbook examples” are discussed as the training tasks but the real production problem from another industry as well.

The revised course scheduling supposes the general theoretical block reduction up to 20% (80 acad. hrs.) of the total make-ready time (it is 40%, 30%, 5% and 5% of the time from 1-4 modules on the Fig. 2, respectively) and increase the total in the volume of an independent project up to 36%.

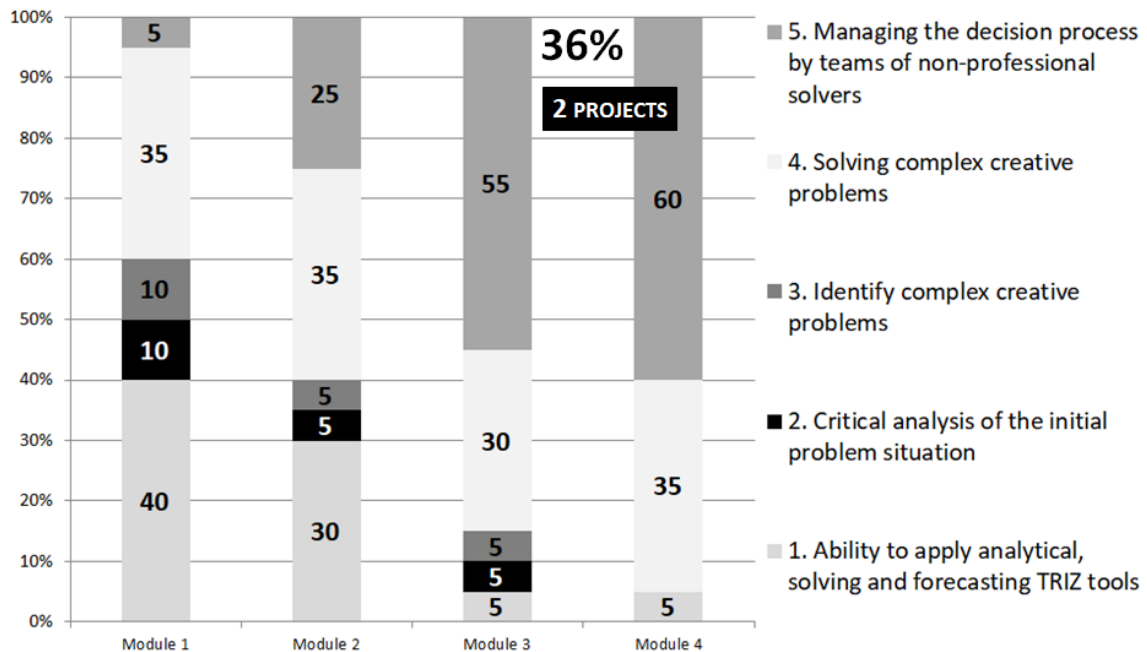


Fig. 2. The course schedule for the internal trainers group

(400 acad. hrs., including 80 acad. hrs. for the study of TRIZ methodology), Flow 2 (2019)

The time allowed for advancing the skills with the TRIZ tools within the training tasks has not been reduced (Fig. 2). Our certified TRIZ specialists faced the problem of the students’ strong professional inertia during teaching TRIZ tools.

One of the ways to eliminate inertia within limited time and high demand for solving the real production problems is the analysis of sufficient quantity of training problems. Such problems can be specific whether in the TS type or in different industries.

However, the need to increase of quantity and diversification of the training problems which are discussed in 1–4 modules leads to decrease of the rate of the students’ progress with the topics of the course (Fig. 3).

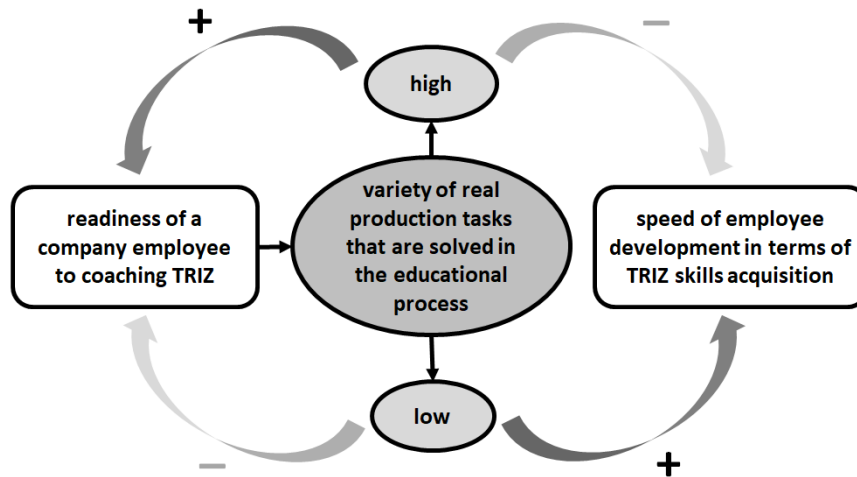


Fig 3. The one of the main contradictions that was formulated during educational Flow 1

The solution to this contradiction (Fig. 3) is discussed during educational Flow 2 (2019).

3 Internal TRIZ Trainers Regular Activities

3.1 Organizational Framework

A company employee carries out many activities performing the role of the internal TRIZ trainer. Such employees:

- implement practical sessions in the 9-days format for other company employees who don't know TRIZ and who were selected by their management for further implementation of the perspective projects with TRIZ tools;
- advise project teams during 1–4 modules;
- organize and summarize the results of training;
- take part in the preparation of the practical cases on a centralized basis.

For many company employees such training on the basic TRIZ ideas and support tools for finding solutions is carried out by internal trainers based on corporate educational and methodical materials. At the same time, the internal TRIZ trainers have responsibility for compliance requirements for the quality of training and for their practical cases prepared by them independently.

3.2 Skills Set

The company employees obtain different knowledge and skills during 1–4 modules. These are:

- ability to apply analytical, solving and forecasting TRIZ tools;
- ability of critical analysis of an initial problem situation;
- ability to identify complex creative problems;
- ability of solving complex creative problems;
- ability of managing the decision process by teams of non-professional solvers.

The employees who graduated of the Flow 1 (2018) were interviewed about what should be the competencies list that an employee carrying out internal training activities on TRIZ in an industrial enterprise should have.

According to 15 respondents, such **competencies** were:

- *general professional*: 1) knowledge in the field of physics, chemistry, mathematics, psychology; 2) knowledge of TRIZ tools; 3) knowledge of the production specifics;
- *personal*: 1) charisma, self-confidence, well-bred speech; 2) erudition, critical thinking, flexible mind; 3) high speed of information processing, multitasking; 4) stress resistance, sociability, sense of humour; 5) purposefulness, hard work, curiosity, enthusiasm;
- *coaching*: 1) the ability to control the audience; 2) “calling” a coach; 3) the ability to convey to the audience complex material in laypeople terms.

15 internal trainers, as an aside, for one calendar year are able to supervise the implementation of about 120 Projects. There is no other statistics at the enterprises of Russia yet.

3.3 Activity Problems

It is necessary to take into account that the internal trainers are production employees who, for the most part, have not had a long experience of public speaking and teaching in the past. In addition, these are employees who were able to study and actually apply TRIZ in only one (in the case of the Fig. 1) or two (in the case of the Fig. 2) production projects. In this regard, among the expected problems related to their activities of internal trainers are the following:

- *team building of employees at different management hierarchy levels of enterprises* (there may be cases when an internal trainer is lower than the employees of the enterprise whom he trains);
- *adaptation of workshops for employees at different levels of the organizational hierarchy* (an internal trainer should have some breadth of vision in the context of professional activity at different levels of the enterprise management hierarchy);
- *synchronization of the problem solving pace by teams taking into account the specifics of the industries and different levels of the initial problem formulation* (as a rule, the internal TRIZ trainer advises four teams, each of which carries out the process of solving a real production problem formulated by the management of the enterprise within 9 classroom days or already is at the beginning of training with the status of the “project”);
- *operational change of the training program depending on the dynamics of the teams* (the internal trainer must have the skills to adapt the training program directly during the training module);
- *accelerated formation and long-term retention of motivation to solve problems and the subsequent implementation of the solutions found* (internal trainer should motivate his colleagues to learn and use TRIZ tools on a regular basis in daily activities).

The issues of professional development and quality promotion of the internal trainer’s activities fall on the TRIZ Front Office. It plans regular training seminars for internal TRIZ trainers on top of it.

4 Training Format Discussion

It is necessary to mark the following **weaknesses** faced by certified TRIZ specialists in the implementation of the training program for internal TRIZ trainers:

- *Lack of expert data* (each student combines TRIZ tools study and solving his real production problem, while not all the information necessary for solving is available – so it is necessary to actively communicate with experts in the intermodular period);
- *Impossibility of rapid testing of the proposed solutions* (solutions require additional verification and testing at the enterprises production sites);
- *Lack of motivation to implement the solution in large holding companies* (the longer the expected path to implementation, the less motivated the employee is to solve the problem with the help of "complex" TRIZ tools which are little known to him);
- *Lack of time to acquire pedagogical skills and project management skills* (close interaction with Corporate universities at the enterprises engaged in additional training of employees is necessary);
- *Insufficient practice of "inside and out" solving problems* (only some projects, the total number of which does not exceed 10-15%, have time to go all the way to implementation during the preparation program; the reasons lie, among other things, in the different levels where the search is carried out – from technical to structural).

The main **advantages** of the existing process of training internal trainers include:

- *Long time for detailed TRIZ tools study* (400 academic hours, excluding intermodular period allocated for independent work with projects and interaction with experts);
- The use of TRIZ training as a subject to look at their activities through the eyes of other departments of the enterprise (the ability to assess the effectiveness of their activities "from the outside", as viewed by super-system "elements");
- Confident development of student's skills of critical rethinking of problems and setting the "right" tasks;
- Formation of a platform for exchange of experience within some enterprise;
- *Integration of TRIZ as a permanent competence in project management* (including the fundamental development of managerial competencies of the company's employees of the operational, middle and upper levels of management).

5 Conclusions

The development of the internal TRIZ trainers Institute within the corporate organizational structure is an unprecedented experience in Russia, which deserves a detailed analysis and rethinking. The materials of this paper contain quantitative assessments of what is happening, as well as a critical analysis of the existing preparation format.

However, it is necessary to remember that special attention should be paid to the detailed qualitative study of the methodological support of the educational process. The implementation of such a process based on the materials of real production problems imposes a number of requirements and limitations both to the level of detail of algorithms for the use of TRIZ tools and to their presentation form. The latter is especially true for specific industrial examples, the

collection, systematization and detailed analysis of which can significantly improve the efficiency of TRIZ training for medium and large business structures.

References

1. Adunka R. Lessons Learned in the Introduction of TRIZ at Siemens Automation and Drives. – 2007. https://www.researchgate.net/publication/265524862_Lessons_Learned_in_the_Introduction_of_TRIZ_at_Siemens_AD.
2. Cheong S., Kaplan L., Prushinskiy V. TRIZ at SMD: Unique Situation, Unique Goals, Unique Approaches. – 2011. <https://www.osaka-gu.ac.jp/php/nakagawa/TRIZ/eTRIZ/epapers/e2011Papers/eSHCheongTRIZSymp2010/eSHCheong-TRIZSymp2010-110917.htm>.
3. Dobrusskin C. How to make TRIZ work in your organization? – 2012. https://www.innovation-services.philips.com/app/uploads/2016/12/how_to_make_triz_work_in_your_organization.pdf.
4. Gardner M. Implementing TRIZ Expanding Skills as a Quality Professional. – 2013. <http://asa-qprc.org/2013/www.qprc2013.com/uploads/Innovation-Gardner-ImplementingTRIZ-QPRC2013.pdf>.
5. Jeongho Shin. What makes Korea so enthusiastic about TRIZ? – 2013. [http://www.triz-japan.org/PRESENTATION/sympo2013/Pres-Overseas/EI02eS-Shin\(Korea\)-130821.pdf](http://www.triz-japan.org/PRESENTATION/sympo2013/Pres-Overseas/EI02eS-Shin(Korea)-130821.pdf).
6. Kyeongwon Lee & INSA Strasbourg. Effective strategy to introduce and propagate TRIZ into companies based on the bad and good experiences in Korea. – 2014. <https://www.osaka-gu.ac.jp/php/nakagawa/TRIZ/eTRIZ/epapers/e2014Papers/eKWLee-ETRIATFC2013/eKWLee-ETRIATFC2013-140330.html>.

Communication

Communicating Author: redkolisev@gmail.com

TRIZfest 2019
September 11-14, 2019. Heilbronn, Germany

FLOW ENHANCEMENT INTERPRETATION EXPERIENCE

Michael Schoewel

Glonn, D-85625, Bavaria, Germany

Paper Classification:

- TRIZ-related methods and tools development

Abstract

Flow enhancement is an useful technique for process optimisation, trimming and value generation improvement. It allows an additional “peripheral vision” to a problem area that can generate additional ideas for a solution by thinking about those “side tracks” of the problem and also provide a judgement criteria possibility for the found solutions. The judgement about the “real” global goal of the investigation/improvement however is tricky as a lowering of the number of flow conversions is often not the only goal within an investigation. So several flow considerations (with different value goals) are needed within an investigation. Depending on the balancing of stability (maximum deviation size) goals with redundancy goals (e.g. failure/ safety/ robustness) with efficiency goals (economical/ financial/ energy/ environmental efforts minimisation and “acceptable” conversion rates for the process) and performance goals (several nominal performance values, often with different scaling or units, also timing and also cost demands “around the process”) and formal goals like understanding, acceptance or “fit” of solution to (technical, social and economical/ ecological) environment and documentation etc., different targets and solutions will be created and also preferred by different people or mindsets. In order to provide a more neutral judgement that can be also understood and agreed within a bigger audience an already working balancing approach from a different field with similar problems is used that also can be used to improve the overall goal description for the flow enhancement investigation in general.

Keywords: flow enhancement, judgement, niche environment transfer, usage of already existing things, trend of coordination

1 Project

Within traditional and SSL lighting processes and product improvements need to be judged for their overall benefit (short/mid/long term, direct and indirect (cost) savings or function improvements resulting in higher product prices). Typical products are lightbulbs of any kind that have several demands to fulfil that need to be balanced vice versa; for process improvements we face the same situation. There are several theoretical possibilities to balance problems, the practical standard is a prioritization acc. “Prio 1/2/3” topics that is often very specific to the

involved people or companies but has no (documented) traceable or even neutral basis of judgement. The key motivation was (among finding solutions to technical problems) to provide a balancing of those weighted factors that is already successfully used in other fields as people need pragmatic and working approaches that allow them to accept those more than their personal guts feelings.

There is a huge variety of already existing scoring possibilities/views available, several also facing similar problems like the combination of different goals with different or even not existing units like a former rating in figure skating. There is not only a need for a “fair” technical and “artificial expression” balancing of the performance with timing balance/impact and a needed consideration of an action timing (as some demanding figures need to be rated higher when performed at the later stage of the performance as the power and concentration of the artist will be reduced due to exhaustion) but also a system that can be easily understood (and supported) by the (non expert) audience. It took years of improvement and discussion to develop an international standard in figure skating (and this story still continues) and not every aspect can be transferred but some parts of the approach could be also used in some parts for a technical and economical balancing of (technical) processes. For direct use the TRIZ method and judgement method need to be shaped/tailored to the specific need.

The balance of different factors need to be set in advance and must not be changed until the final score is made for all “competitors”. Readjusting specific points later in order to support a management guts feeling better is one of the easiest ways to generate a heck of long lasting anger among all participants not only due a violation of “fair play” but also of “moving targets” that were intended to be stationary. This causes a loss of trust (ergo motivation) usually. Also in fault tree analysis (FTA) we face the same situation that all of the effort becomes worthless when the target values are changed.

An arbitrary possibility is to balance (seven) *goal balance factors* for

performance	(nominal product values, also benefit of (economical) usage)	e.g. 25 %
stability	(deviations of nominal values, also product manufacturability)	e.g. 20 %
efficiency	(performance/usage to production/energy/manpower effort ratios)	e.g. 10 %
redundancy	(parallel backups, FTA with the balance of alternative endings)	e.g. 10 %
safety	(considering the impact of “alternative endings insurance costs”)	e.g. 10 %
formal goals	(understanding and acceptance, “fit” in (customer) environment)	e.g. 20 %
environment	(ecological process and waste handling, fit in strategy/experience)	e.g. 5 %

for the overall final criteria. Each factor can assume a value between zero (total fail and block of solution) and one (perfect solution for this criteria) for a specific solution. After this all local factors will be individually multiplied with their relative importance and the sum of this multiplications provide the final score for the specific approach like it is done similar in a morphologic box acc. to Mr. Zwicky’s approaches [1]. Already with this linear balance in advance, several problems arise and in an open discussion about this topic we will face an emotional bazaar scene within short notice as most of the related people intentionally want to protect and stress their share and achievements (importance).

Even when there is a rough settlement for this balance of those factors, it is obvious that some effects within the judgement can not be considered like blocking items of solutions that would

demand a “no go” veto for some option, e.g. when (law) limits would be violated by a solution approach. However a request for some minimum values in each (sub) rating can handle this topic easily, but brings a second (mandatory) goal for each investigated solution possibility into the judgement considerations. But this just the beginning of the story.

Considering that most effects also face some saturation in their overall impact, we can introduce a S-curve from zero to one, making also an area possible where a local effect improvement can contribute more or less than in other areas. This limits the impact of (side) improvements to an overall solution. However the way of “doing the sums” has multiple possibilities that will cause even totally different results with the same input. A multiplication of all factors would easily solve the problem of a subfunction “veto” (as one “close to zero”-value sets the overall score also close to zero) but this would spoil the balance of the different ratings and would treat each individual improvement similar which is usually not the case. The compensating usage of exponential factors “on top” will dampen this slightly but this causes some additional luting. One different approach was the introduction of a S-curve generated by the modified arc tangent-function:

$$contribution_{subvalue} = \arctan((points_{subvalue} - shifting_{value}) * factor_{impactwidth} + \pi/2) / \pi \quad (1)$$

where the $shifting_{value}$ is the position of the inflexion point (where 50% of the possible contribution is achieved when the $points_{subvalue}$ reach this value) and is $factor_{impactwidth}$ (indirectly) specifies the slope of the S-curve around the inflexion point and therefore also the “impact area” of the (local) contribution. This considers effects on both sides of the operating point providing not only a kind of minimum score for a single factor that needs to be achieved by the approach in order to be accepted but also a consideration of the border zone. It is expected that the usage of integrated gaussian distribution formulas are way more precise to describe a more realistic contribution impact, however the approach with an arc tangent function is much more simple and already sufficient for several problems. With this arrangement each $contribution_{subvalue}$ of a solution approach achieves a local relative value between zero and one. This value can now be multiplied by the former factor defined by the *goal balance factors* and all $contribution_{subvalue}$ can be added for the overall value points of a specific solution. It is notably that a “veto” of a subvalue still can be overruled here, however this approach already represents a “non digital border thinking” that can be also found in other quality tools that focus on process stabilities [2] and already indicates a minimum violation as the local $contribution_{subvalue}$ of such a solution becomes a very small number.

Depending on personal preferences, different quality factors will be mixed differently and with all that mathematical exercise the results will still be (mostly) a reflection of a personal guts feeling. However “playing with those values” helps to understand and balance the demand in a better way. A questioning of the balancing allows to “improve the experience” with the (stability of the) demands. Doing this already in advance is highly recommended also in relation to a situation understanding of the participants and stakeholders.

2 TRIZ relation

The flow enhancement approach was used in combination with a balancing method that is also close to an older ISA regulation for figure skating. This combination of multiple investigations and local judgment allows an overall judgment on workshop level for a balance of technical an

semi- or even non-technical terms based on a more neutral metric. This allows to consider more parameters than a single nine screen method approach.

The TRIZ technique trimming tries to reduce the components, mostly those who are not in direct relation to the main function, which is the goal and the “end to the customer” interface. Flow enhancement however is focusing on a linked process chain. This chain has not only a defined end but also a start where the starting value is set to „zero“ by definition. The goal is not (only) to reduce steps but also to ensure redundancies, robustness and product stability ect... Goals that cannot be transformed vice versa in an unlimited way. Therefore multiple flows have to be created where each flow has to achieve a former defined minimum values ensuring that every solution is tested against this criteria.

Each flow can be seen as a process that generates at least one (desired) value in (mostly irregular) steps starting from zero (or keeps it at a homogeneous and constant value which can be considered as an inspection or investigation to its flow momentum or derivation).

But each flow can be also seen as a different model approach, allowing a different point of view to the (same or related) problem sometimes even with a different direction. The “picture” of understanding of a problem (set) can be extended with several (flow) approaches.

We regard several (process) flows in TRIZ[3] (where often time is the only “really unique” identifying scale) separated in 3 classes, that provide a different view to the problem(s) based on different flows or transformation/transfers. The following flows are understood as a possibility for this kind of flow investigation.

substances: → material, stock, logistics, but also production or “digestion” and also (transfer) concepts like “pollution disposal”, abrasion or conversion, also for/with “interfaces” marking steps that already count efforts or efficiency drops (indirectly) as well as “negative side flows” of (waste) related components (e.g. parts that need to be moved in order to allow the material move/flow). Also “leakage” or pollution flows that cause additional efforts for their disposal) and (lasting) footprints or traces/ residuals of already performed processes that can interact with other components or field flows

fields: → (mostly) energy or its analogon like heat, current, cash, value, power, and all kinds of controllability or negative “harm” like efficiency drop ect.) but also (spent) time (e.g. per process) or “control” that are also indirect indicators for energy efforts

but also information: → (user/trigger/click) actions, understanding or “communicated transfer”, development progress, but also “information losses“ (content, traceability) or “failure” like in a FMEA/FTA analysis) and (mostly) “time” (that sometimes does not even change another component or parameter directly except age...). Also error propagation or even “motivation”, “competence transfer” & negative “confusion” that can be interpreted as a kind of information flow and “growing” (often positive definite) results like accuracy (e.g. with error propagation), value (stream), mass grow/loss or “simple counting”(e.g. number of interfaces, spent money, user actions e.g. clicks) and all kind of their interactions,

ratios, derivations (e.g. “momentums”) and integrals that describe the step condition or its change compared to the other steps/states.

Those generated values are often regarded as the process result itself and even as detection/counting/improvement or judgement information and even the (only) goal (“score values” of any kind, clicks, number of interfaces, (deviation) stability, (process) robustness, (fallback) redundancy, emissions values up to money savings, ROI, EBITA etc.) of an investigation/improvement approach as it is also visible in the trend of coordination for substances and fields. So all three groups (substances, fields and information) generate a (positive and/or negative) value within their flow that is different to the other five (in direction and/or unit).

In most cases this allows six different approaches for a value improvement (3 classes (material/field/information) with 2 directions each (positive (generating a value) and as a complementary “negative” (generating an additional effort or a value reduction)). As several flows can be made with or around the same component, the number of possibilities is linked to the involved components and their parameters.

This modelling approach is that common and stable that it even can work within some limits although the physical background is not even “really” existing. An example therefore is the part design in mechanical engineering where the students try to optimise their constructional sketch with the (technically wrong) concept of an intuitive “force” and/or “torque” flow. As Newton[4] already told the (sum of all) forces are in balance all the time, so a force balance is no process (with timing impact/delay) but a condition. However, it often seems easier for mechanical designers at start to develop their understanding in small steps from a starting point with just a few intuitive rules (with limited validity) before an understanding of a general concept can be established although there is also the other way round also possible. So by changing the direction of the (investigation) flow not only a different view can be generated but also different solutions can be found.

The need for a flow in physics is basically a gradient. The demand of a gradient for a possible information transfer (flow) was nearly directly linked with a longer time of (general lifetime) experience until people have “something to tell” or teach to the inexperienced ones. A change in society is nowadays evident in several fields that happened within the last decades on a way broader basis. It is now common that children can (and do) teach their parents things about internet, mobile phones, social media and networking, although their lifetime experience is way shorter. Sometimes even their specific experience with a new tool is shorter than their parents that tried harder and for longer time e.g. to change the background picture of the mobile phone. The reason for this phenomenon is not always pure luck or impartiality of the younger kids but can be also seen the different direction of the approach that is expecting an intuitive but not structural or machine based way of thinking. Therefore a change in the directions is recommended also in a flow enhancement investigations in TRIZ, although some concepts (e.g. “reverse the time flow”) seem crazy at first glance. With the assumption that a flow investigation is differently motivated and directed it can explain why better results can be archived with less (but different) effort but similar or even same resources.

Although a gradient seems still mandatory for any kind flow (also money transfer), it seems that this is not the only external factor that specifies the amount of flow (internal factors like resistances or capacities are already considered) but also the kind or direction of the flow seem to have some impact defined by the supersystem.

The flow enhancement investigation splits a general action into several smaller tasks, allowing regional improvements or even trimmings by merging, function transfer or removal.

When a process is also split into several kind of flows (e.g. material/interface flow, value generation flow, logistics flow) those different views can provide individual improvement possibilities. Also a single kind of flow can be split (to main and side paths), e.g. for redundancy considerations. A possible example therefore is the “domino day problem” where the TV company wants to ensure a live event lasting at least a specific time where arranged “building bricks” fall “in a row” in order to achieve a (counting) record. In order to ensure the live-TV appearance time, next to the “main (camera) path” where specific artificially set up fields are triggered, there is an (unspectacular) “heartbeat” line with some delay, ensuring that even when a field does not trigger the next field due an modelling error or blocking, the trigger for the next fields comes delayed as a redundancy in order not to stop the reaction early in front of the prime-time audience. Redundancy is not just a request for TV shows or Mars landings; several technical issues need to consider it. Therefore a flow enhancement needs to provide a metric for this and the (minimum) number of parallel (side) flows (and their crossings with the main path) is one possibility for looking to weak points as any further task relies on the successful performance of a single action when there is no side path. Also out of each action in the flow a (new) fault tree (flow) can be started that allows the judgement of the probabilities for the occurrence and the impact to the overall system based on the regional factors. It is often helpful in mapping to mark fault trees, e.g. by a different direction (e.g. regular flow “from left to right” while the fault trees “fall downwards”) or different colour in a traditional flow chart with logical “switches”. If flows can be returned to the main path at several stages, the number of those stages can be also used as an indicator for redundancies.

An (IT-) flowchart that is focussing to show the actual process stage conditions and the unique possibility in each stage for the continuation of the process is called a “state machine”. Those state machines are also used in production for multiple product recipe definitions and are very handy to understand the process flow. State machines can be also (seen as) an intermediate result of a flow enhancement investigation in this kind of approach.

A (process) flow was understood as a dynamization indicator (like a derivation or momentum rate) of a parameter across a second axis (that can also indicate value) like time, process step, interface, money etc. As this also generates a value, we can use this approach to understand a relation of (two different) values (e.g. time and percentage of the final product creation) to each others within different process steps with different (relative) output.

A strong linkage to (esp. shape an rhythm) trends and to the main parameter of value considerations [5] is regarded here, but needs further investigation if or how this different point of view to this topic from a flow perspective can provide additional benefit to already existing methods. It is assumed that trends show a history of a general value generation in a bigger pattern while flow improvements are focussed more to the specific problem like within the MPV-approach.

A mesh was understood as a flow possibility where each node provides switch points to another string (line). The number of switches were regarded as an indicator for additional functions, even when the switch lead to a dead end; e.g. several railroad lines have a rail switch at the “foot of the mountain” that lead to an open side-way “downwards”. With this arrangement a situation of disconnected wagons while the mountain climb of a train can be handled ; the wagons will be guided to the open side-path so they don’t jam the main path for further trains or even endanger already passed railroad stations when running back from the hill after a connection break. Even when the wagon is lost then “in the green” the overall situation is improved in terms of control. Such “graceful degradation” paths need also (at least small) resources but can generate an additional value in terms of redundancy (e.g. robustness) and/or safety. With this kind of flow investigations neutral tools can justify the needed efforts for those measures.

Even a direction change can be seen as resource (parameter) in a flow chart. One example for this is a delayed train that is commuting between 2 distances and wants to get back to regular schedule. Therefore there is a possibility to stop the movement, miss one oscillation and be back in regular schedule. This arrangement reduces the overall delay considerably with the side effect of one total loss of a connection. Although an individual passenger (in the lost connection) might not appreciate this approach, the overall benefit for all of the other commuters is visible at least to the train company.

As a flow is also an information and so according to [6] we have to check the content for completeness, explicitness, correctness, topicality, accuracy, consistency, redundancy, freedom degree, relevance, uniformity, reliability and comprehensibility. Although this might be regarded as a “side topic” at first glance, by doing this (even when there seems no direct benefit in doing so), surprisingly many additional ideas can be found for the flow improvement, as the “learning by modelling”-approach allows us to get rid of several bias within the investigation when performing this kind of “peripheral vision” around the problem area.

3 Results

As a result, flow enhancement was understood as a multiple approach to generate (additional) values within a product/process investigation due multiple ways. Each way is a different possibility of doing so and can deliver different result contributions. Those contributions can be added an balanced in the described way in order to achieve a global score for comparisons of different ideas/solutions. With this method made judgments can be more intuitive and reasoned more neutral. It is intended to continue this kind of approach also within a bigger frame within the product and process development than the limited possibilities of specific/local (process and product) applications. Further details to specific solutions are actually related to IP, therefore individual examples are given for each subtask.

4 Conclusions

As an advantage a better overview of different approaches is regarded with the application of this method. Also the possibilities to balance different solutions on a more mathematical basis is appreciated for management decision sheets as a more neutral judgment value/criteria can be presented for comparisons to an audience with more technical distance to the problem. Also the ideas and results of other approaches (e.g. 40IP or ARIZ) can be judged with this (scoring) approach. A brighter team acceptance and granted IP's show the impact and effect of the approach.

References

1. Zwicky, F. (1969). “Discovery, Invention, Research - Through the Morphological Approach” Toronto: The Macmillan Company
2. Boyles, Russell (1991). "The Taguchi Capability Index". Journal of Quality Technology. 23 (1). Milwaukee, Wisconsin: American Society for Quality Control. pp. 17–26. ISSN 0022-4065. OCLC 1800135.
3. Ikovenko, S. MA TRIZ Level 3 Training 2016/17 Week 2/2, p89ff.
4. Newton, Sir Isaac (1729). "Axioms or Laws of Motion". The Mathematical Principles of Natural Philosophy, Volume I

5. <https://matriz.org/wp-content/uploads/2019/03/TRIZ-Review-vol-1-no-1-1.pdf> p80ff, reviewed on 30th of March 2019
6. <https://www.business-information-excellence.de/datenqualitaet/86-datenqualitaet-messen-11-datenqualitaets-kriterien> (german), reviewed on 30th of March 2019

Communication

Communicating Author: michael.schoewel@live.com

TRIZfest 2019

September 11-14, 2019. Heilbronn, Germany

FOS WITH OPERATING TIME

Jungin Kim^a, Yusin Han^b, Ahreum Lee^c, Gukhyun Cho^d, Wanseok Jeong^e

^{a, c, d, e} 222, LG-ro, Jinwi-myeon, Pyeongtaek-si, Gyeonggi-do, Korea

^b 601, 221 Yeoksam-ro Gangnam-gu, Seoul, Seoul, Korea

Paper Classification:

- TRIZ-related methods and tools development
- Case study

Abstract

FOS is widely used as a tool to quickly solve problems by applying technology which is existed in another industries to contradictions and general problems.

And we generally use the FOS in idea stage.

However, if using it with Operating Time in the problem analysis stage, we can use it to set the solution direction as a problem analysis tool.

So, this time, I would like to find out how to utilize FOS together with Operating Time, along with the case of the shampoo pump development project.

Keywords: *FOS, Operating Time, Idea Generation*

1 Introduction

FOS is to find an existing Technology (Product or Process) and transfer it to the Initial Problem, as a Solution. Thus, we can offer a new and very effective Action Principle to solve the initial problem; we also do not need to spend a lot of time and effort proving the effectiveness of this new solution and putting it into practice, because the Technology already exists. [1]

Operating time is introduced ARIZ 85C Part2 'Analyzing the problem'. The model is defined as follows. The operational time is when there is available resources of time: the time when conflict occurs (T1) and the time before the conflict (T2). A conflict (especially high-velocity, shortterm) can usually be eliminated (T2) during T2. [2]

According to each definition we know that Operating time is used in problem analysis stage and FOS is used in idea stage.

However, if we use Operating Time and FOS together in the problem analysis stage, we can analyze the problem from another point of view.

2 FOS with Operating Time

When we analyze the function, we can define the function in terms of Operating Time. Defining a function from the OT perspective can reveal what functions are happening sequentially in order to get the final result. And if those functions are defined individually, we can find a system that performs similar functions for each function through FOS.

In some ways, this can be a more extended concept in the AFA (Advanced Function Analysis) concept. AFA schematizes functional analysis diagrams taking into account time and space variables. So AFA is more effective than the function analysis because it can help you understand the sequence of the work clearly or through a structured understanding of the inter-system spaces and interrelationships.

When the concept of time is included in the functional analysis, more efficient analysis is possible.

So we thought FOS also is used time concept and it could be more efficient analysis as AFA.

This time we suggest to use FOS with operating time at analysis stage, we can get more ideas for future solutions. This analysis can also be used to create new products because it can replace the functionality itself.

So let's see how we actually used it through case studies.

3 Case Study

In 2016, LG H & H carried out a new pump development project. This project was aimed at reducing costs by making half the number of parts. (The number of parts: 12ea → 6ea)

Since it was a cost reduction through the reduction of number parts, so we approached the function analysis and trimming at first.

The technology system was pumped, Target defined as shampoo, function shifted shampoo position. The function analysis was carried out by dividing the pump into two points at the time of pressing the pump.

The function analysis was carried out as follows, and it was evaluated that there is no harmful or insufficient function as seen.

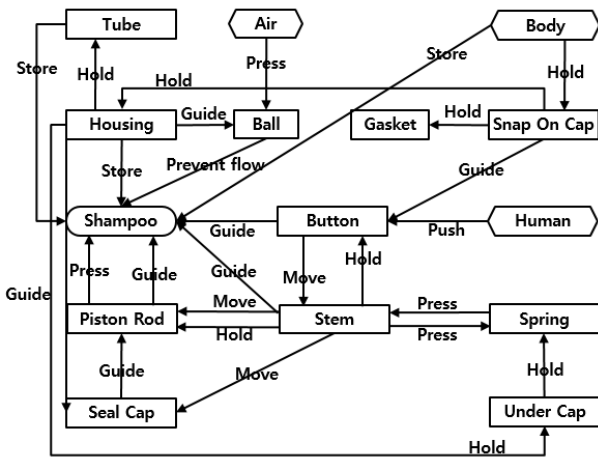


Fig 1. Function Diagram: Press Pump

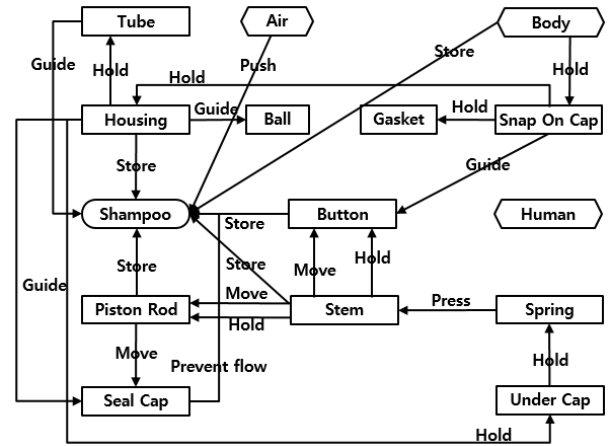


Fig 2. Function Diagram: Pump Goes Up

The next trimming part was selected and the number of parts was reduced by the trimming method. So we can reduce the number of parts, but it did not reduce the number of parts as desired. (Number of parts: 12ea → 9ea, We wanted to reduce the parts of half.)

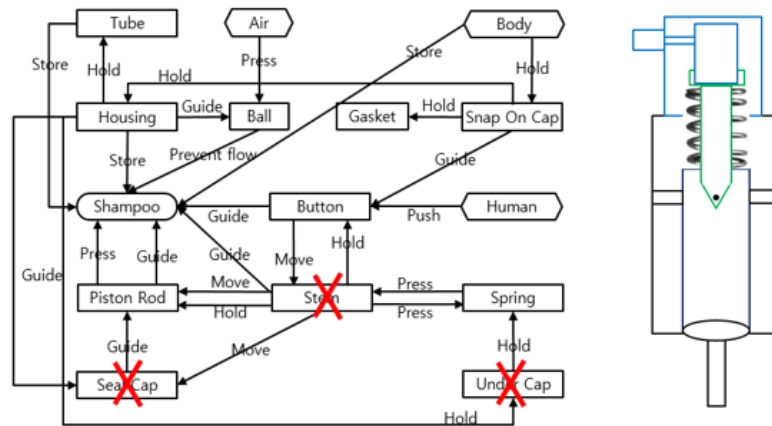


Fig 3. Trimming and Idea

So I decided to approach the approach in a different way than the general methodology of Trimming. We decided to break down the time it takes to run the function, and then look for different ways to do each function.

First, we segmented the time that the pump's function worked, so we could see that it was divided into four points. When the pump was first pushed, the shampoo was transported and stored inside the pump through the tubing, and then discharged through the pump internal part with a constant shape out of the pump. After rearranging them again, you can rearrange them by moving, storing, moving, and controlling the ejection shape.

Nest we tried to find out how to perform each function through FOS.(Move → Storage → Move → Shape Control)

Then we knew how to perform each function by some principle. (Bellow the figure 4)

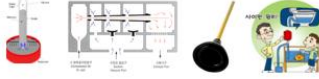

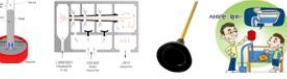

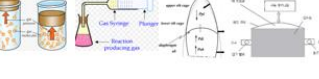

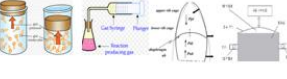





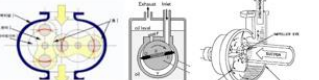

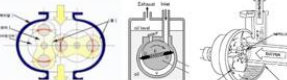
Move	Storage	Move	Shape Control
<p>1. Pressure difference</p> 	<p>1. Control with scale</p> 	<p>1. Pressure difference</p> 	<p>1. Discharge Size</p> 
<p>2. Volume decrease</p> 	<p>2. Package</p> 	<p>2. Volume decrease</p> 	<p>2. Entrance quantity</p> 
<p>3. Direct move</p> 	<p>3. Store in a container</p> 	<p>3. Direct move</p> 	<p>3. Appearance</p> 
<p>4. Change internal volume shape</p> 	<p>4. Time Control</p> 	<p>4. Change internal volume shape</p> 	

Fig 4. FOS with Operating Time

As you can see from the above, there are various principle for the same function. And even if I had to do a combination of these different methods, I noticed that there were other products besides the original pump.

The conventional pump is represented by a combination of 1, 3, 2, and 1, the combination of 1, 1, 1 is represented by a sphere, 1, 1, 2, 1 are represented by a syringe, 1, 3, 3, and 1 are represented by fountain pens.

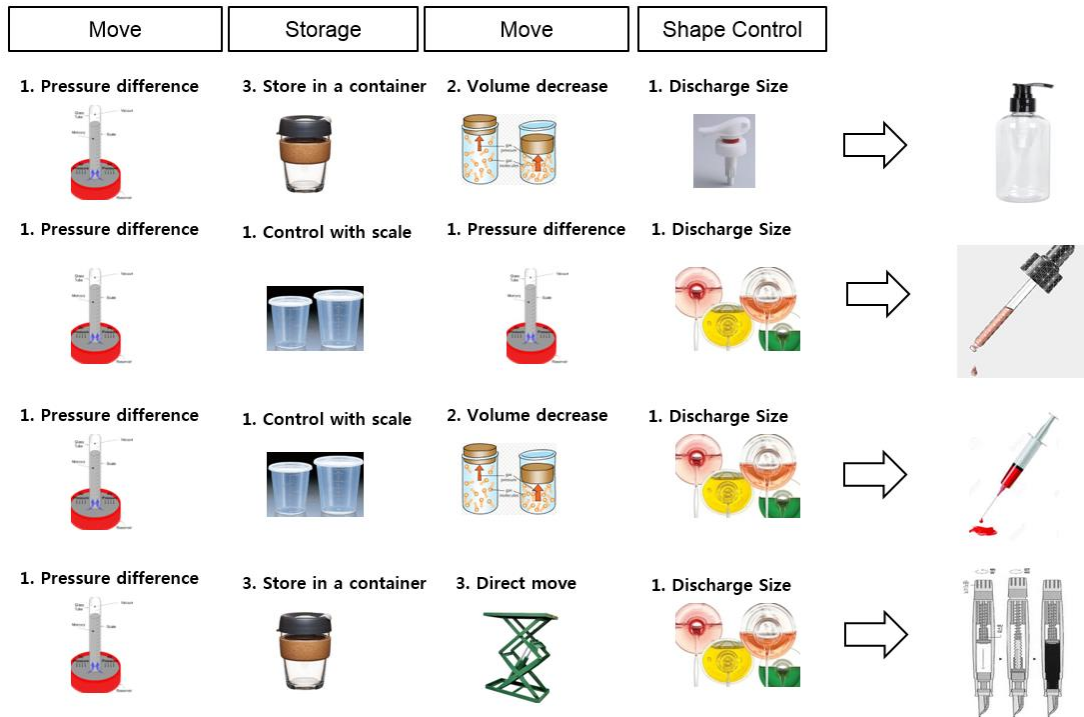


Fig 5. Matching Product

Based on this tendency, we changed the operation method of the pump and trimmed it by combining functions. Trimming changed the Storage and Move functions to No. 1 and No. 1, and we were able to get a new idea called Bellows.

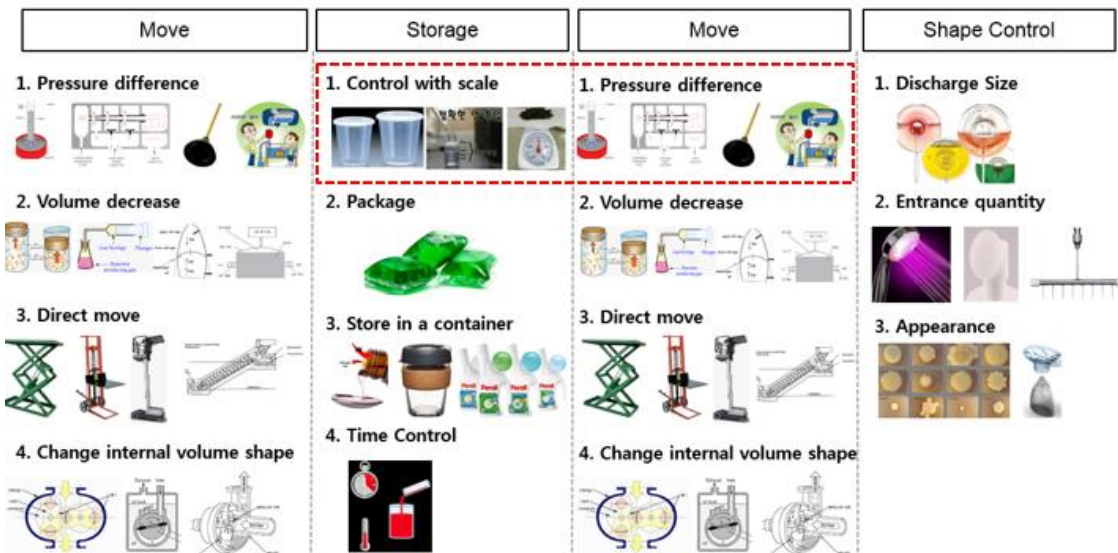


Fig 6. Trimming Idea

4 Conclusions

In this way, the Bellows engine came up with the idea of a new pump engine, which dramatically reduced the number of parts from 12 to 6.

Especially, we can reduced the number of engine parts from 7ea to 2ea. Because bellows engine can be stored and moving by one part.

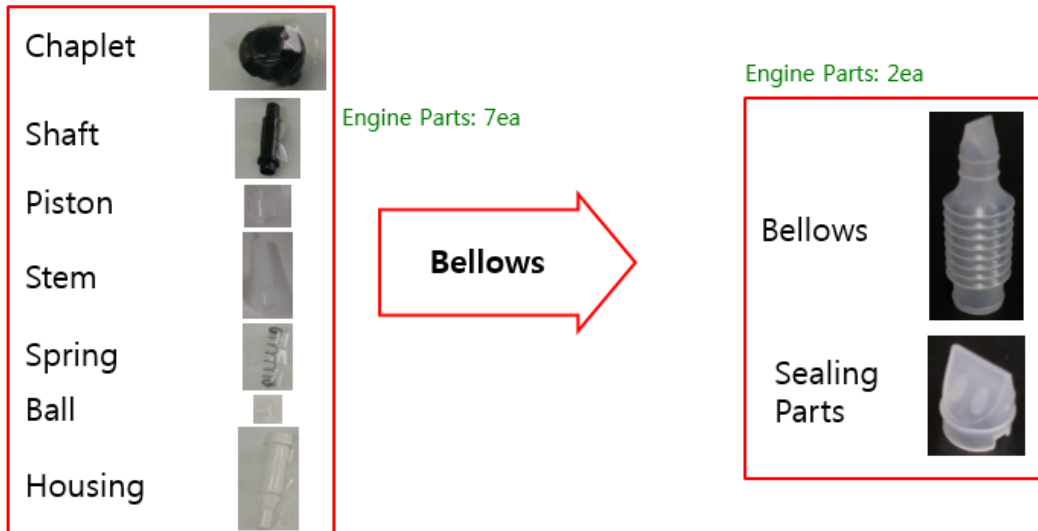


Fig 7. Compare with Existing Pump Engine and Bellows Engine

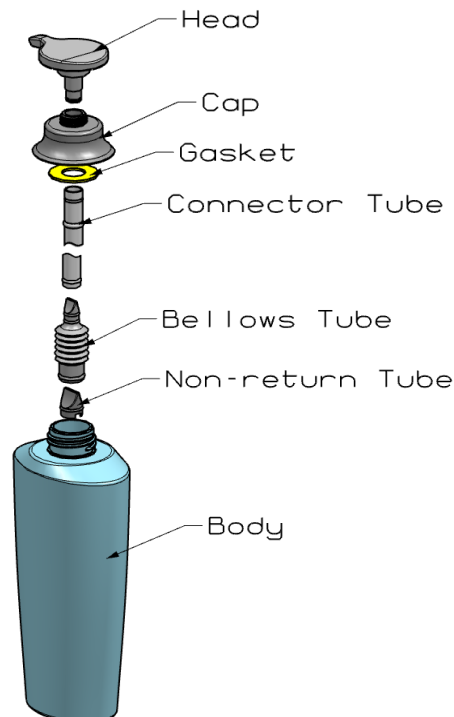


Fig 7. Final Result of Pump

So, with this experience, we think that using FOS with the Operating Time Tool at the problem analysis stage will create more problems and various problems.

In the future, we will try to apply more cases and make more progress.

References

1. THE TRIZ JOURNAL: New TRIZ-Based Tool-Function-Oriented Search (FOS), 2005
2. <https://triz-journal.com/new-triz-based-tool-function-oriented-search-fos/>
3. Altshuller G.S., ARIZ Means Victory. Algorithm of Inventive Problem Solving ARIZ-85-C.- Rules of Game without Rules / Compiled by A.B.Seliutsky. – Petrozavodsk: Karelia, 1989.

Communicating Author: jungin81.kim@lge.com

TRIZfest 2019

September 11-14, 2019. Heilbronn, Germany

FORECASTING DIGITAL RADIOLOGY MEDICAL DEVICES

Srinivas Peddi

Philips India Ltd., Pune, 411018, India

Paper Classification:

- Case study

Abstract

Digital Radiology systems, called as DR systems generate X-ray imaging for capturing data during patient examination, immediately transferring it to a computer system. There has been significant development in X-ray imaging over the past 2 decades ever since its existence. While there is growing market need of these systems in the coming years, this case study forecasts the future of these systems studying important parameters responsible for their historical developments over the years and connects it to the future demands of the markets. S-curve analysis, Main Parameters of Values (MPV's) connectivity and Trends of Engineering System Evolution called as TESE provides direction and forecasts for these devices.

Keywords: *Digital Radiology, Medical devices, TESE, Forecasting methods and S-curve analysis.*

1 Project

Royal Philips is a diversified technology company, focused on improving people's lives through meaningful innovation. Our health care business makes up 42% of our global sales revenue [1]. From mobile units to complete digital X-ray rooms, Philips provides radiography solutions that fits variety of workflow and budget.

My main task is on enabling innovative solutions for next generation systems and drive reliability through innovation.

For the medical devices, Digital Radiology segment, Digital X-ray market is expected to reach USD 13.04 Billion by 2023 from USD 8.68 Billion in 2018, at a CAGR of 8.5% [2]. This calls for increased focus on newer developments and trends to stay ahead of the competition meeting the customer demands.

In typical engineering R&D's, the development of next generation product in the industry is a function of forecasting models developed by the Product marketing combined with the inputs from the applications team.

These models are mainly formulated from several "Voice of Customers" (VoC's) based tools such as Customer surveys, Interviews, Quality Function Deployment (QFD), Kano model,

Competitive analysis, Market Trends etc. as the main input. Coupled with inputs from the service by taking in to account existing issues, call rates, reliability issues etc. a future model is developed to have a definitive winner in the market.

While these models have proven to be successful, their growth rate is generally incremental.

They can be improvised or take a larger leap in development if the same is coupled with Voice of Product (VoP). VoP is an important aspect of Product Innovation Strategy and utilizing Trends of Engineering System Evolution (TESE) fits in this category. The current motivation is to utilize the VoP and develop a forecasting and vision based case study for medical devices considering few parameters of value.

Initial steps of market trends from research reports help understand the expectations of the market in the coming years.

1.1 Market Trends:

As initial step, research reports focusing on the future of the Digital Radiology are taken in to account for the purpose of the study. These help us to arrive at the parameters of value that markets need going forward. Extract from couple of these reports discussed below:

Market Trend - 1:

The price of DR systems will continue to fall, acting as a brake on revenue growth [3]. In the short-term, **workflow**, productivity and **operational efficiency** will be focus areas for product development. Moving forward, more advanced machine learning and AI capabilities will be embedded in DR systems, with an initial focus on tools that improve workflow and productivity by offloading routine tasks and supporting on high volume cases.

Market Trend 2:

Emergence of **portable** digital X-ray systems. The market is witnessing a growing use of portable digital X-ray systems owing to its advantages such as low weight, **easy mobility**, and easy **operability** [4].

Coupled with these reports, the inputs from customers via product marketing and internal intelligence of the company with respect to competitive analysis is considered. In the interest of this paper, the following parameters are shortlisted for further detailing as a case study viz:

- a. Workflow improvements
- b. Compactness

2 TRIZ relation

With the above inputs, the following methodology for utilization of TRIZ tools is adapted [5].

Main parameter of Value (MPV) Analysis: Initial MPV's from market research reports are considered. Subsequently a deep dive to understand the current development of system over the past 2 decades are categorized under various MPV's connecting them to the high level needs and future MPV's of interest.

S-curve Analysis and TESE: MPV's are plotted on individual S-curves to understand the stages of their developments and eventually the study concludes by taking in to account the various laws/ TESE rules to come up with the next developments in medical device industry.

2.1 Main Parameters of Value (MPV)

For any industry (in general) the following high level needs formulates the development of the next generation engineering system viz. Performance, Controllability, Convenience, Health & Safety, Sustainability, Manufacturability, Cost and Brand. So it is imminent for the market trends to merge with the higher level needs.

Following MPV's are chosen for next generation including inputs from above mentioned market research reports and other teams: Workflow improvements Intelligent software algorithms, and HW compactness.

Detailed back reports on the developments enabled to understand how the historical development was carried out against each Main parameter of value. These are shown below.

Table 1

Derivation of Main Parameters of Values (MPV's)

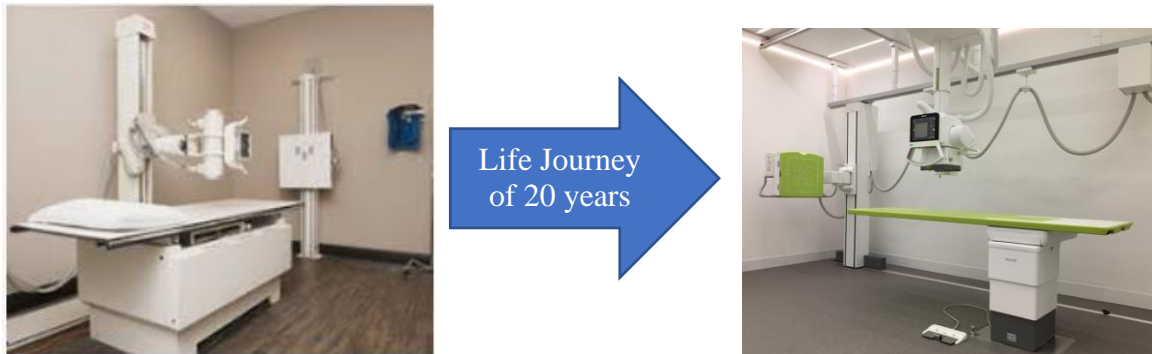
High Level Needs	Strategic MPV's	Level – 1 MPV's	Level – 2 MPV's	Versions of Evolution	Years of Evolution (Indicative only)
Work Flow	Image Quality	Image Post processing	Workstation efficiency	Machine (M/c) A.1, A.5	2000, 2015
			Intelligent software algorithms/ updates	M/c A.1, 1.x, A.2, A.3, A.4, A.6	2000, 2001, 2004, 2006, 2010, 2019
Convenience	Cycle Time	Ease of usage	Easy UI	M/c A.3, A.4	2006, 2010
			Ease of movements- Ergonomics	M/c A.1, A.3, A.5, A.6	2000, 2006, 2013, 2019
			Geometry portability	M/c A.5	2013
	Ergo-nomics	Efficiency & Flexibility	Degree of automation in Hardware (HW)	M/c A.5	2013
			HW mechanics flexibility	M/c A.2	2004
Cost	Equip-ment Cost	HW cost	Supplier manufactur-ing cost		
			Bill of Material cost	M/c A.3, A.4	2006, 2010

			Tooling cost		
			Transportation cost		
Installation Cost	Labor cost	Time of installation	M/c A.3, A.4	2006, 2010	
		Geometric modularity			
		Specialized labor skills			
		Integration of system with hospital	M/c A.2	2004	
		Specialized assembly tools			
Service Cost	Maintenance cost	Corrective Maintenance cost			
		Preventive Maintenance cost	M/c A.6	2019	
	Spare part cost	Spares provisioning			
Cost to Company/ Customer (Foot Print)	Geometry compactness	HW compactness	M/c A.1	2000	
	Low force mechanics	Servo/ alternative designs			
Cost to Customer (Room space/ layout space)	Ratio of equipment cost/ room cost	Geometry (HW) Dimensioning	M/c A.1, A.6	2000, 2019	
	HW flexibility	Mobility			
Sustainability		Reliability	Availability (Uptime of systems)	M/c A.2, A.4	2004, 2010

	Service Packages	Multiple tests packages	Functions such as blood level tests etc.		
--	------------------	-------------------------	--	--	--

These sub-categories are categorized further till it is flow down to engineering parameters.

The medical device industry in fixed radiology has been around for close to 2 decades (Refer Figure -1) and if we deep dive in to the past versions, the same can now be visualized on which parameters the past versions been focused on to improvise with respect to time as shown below.



Above figures are only for reference.

Figure 1. Development of DR systems

2.2 S Curve Analysis

Subsequently the chosen MPV's are plotted on the S-curve to identify how the past development has addressed these MPV's. These are indicated on the S-curve shown in Figure 2.

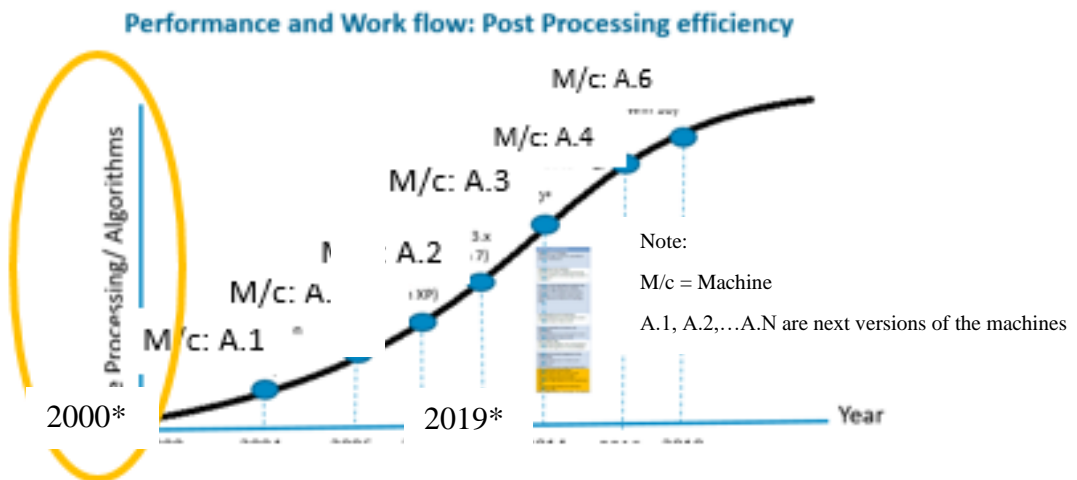


Figure 2. Image Post Processing MPV plotted on S-Curve Analysis

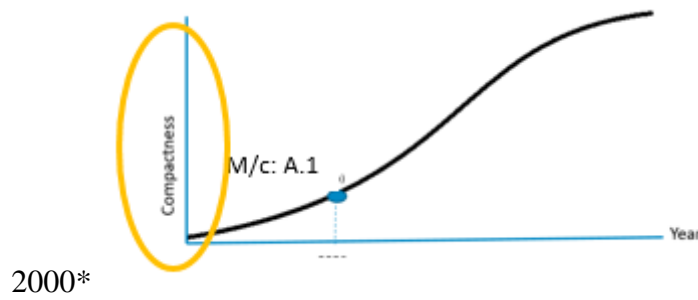


Figure 3. Compactness MPV plotted on S-Curve Analysis

From the above figures 2 and 3, it's noted that for the MPV of Image processing algorithms the parameter is currently at stage 3 end and nearing stage 4. However, it is imminent also from the market trends that there is a need to shift to a new operating principle such as Artificial intelligence.

For the MPV, compactness (figure - 3) not much developments have been focused hence there is a need to identify problems to address compactness. Hence some of the problems that could formulate a sub set would be how to reduce volume of a particular component? A good way further would be to start with the function modeling and identify the key functions to resolve from volume standpoint.

2.3 Trends of Engineering System Evaluations (TESE)

2.3.1 Key elements of Digital Radiology

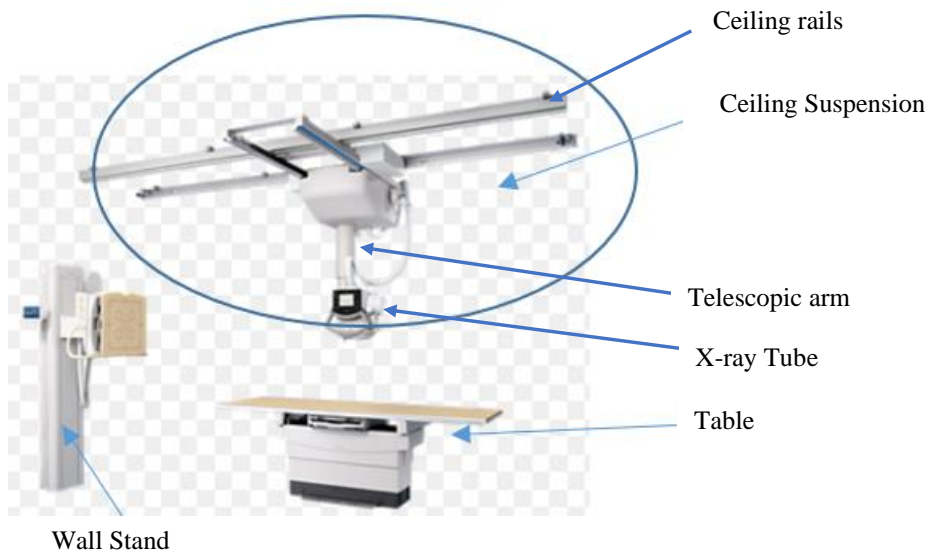


Figure 4. Digital Radiology System – Ceiling Suspended

TESE states that systems evolve over its lifetime and key elements develop sequentially starting with the operating agent, followed by transmission, energy source and control systems. These are identified in DR systems as below:

Operating agent is the part of the system that performs the main function. In DR systems (Refer Figure-4), this is the X-ray Tube, since the whole system caters to the need for generating X-rays and utilizing X rays for digital imaging.

Transmission system is the part of the system that caters to supporting the X-ray tube. At a sub-system level, Telescopic arm, and ceiling rails cater to these requirements. Telescopic arm supports the X-ray tube and provides flexibility to X-ray tube for movements in 3 degrees of freedom such as vertical axis and beta and alpha axis (that is about vertical and horizontal axis respectively), while ceiling rails help in linear axial movements.

Generator forms as the energy source and software and operator are the control systems.

In the subsequent sections, various trends and sub-trends are analyzed for guidance towards forecasting the next gen system. Relevant trends to this case study are explained below.

2.3.2 Trend of increasing degree of trimming:

This trend is on the genesis that as the engineering systems evolve, the system elements need to be trimmed in the following order:

Transmission System followed by Energy Source, Control system, and eventually the Operating agent

Hence basis this sub-trend, it is forecast that as the system evolves ceiling rails and telescopic systems may be eliminated first.

2.3.3 Trend of transition to super system:

This trend states that as the system evolves it merges with the super system components (in DR, ceiling suspension system could merge with super systems identified are Wall Stand, Table, Generator, Ceiling, and AWS).

Further Sub trend analysis provides interesting directions to the thought process.

Increasing differentiation of parameters: indicates that similar flexibility (degrees of freedom) exists as that of the engineering system within wall stand and table. In short, three sub systems have similar degrees of freedom. This needs to be re-assessed if all three need to have different mechanics for similar degrees of freedom.

Study of competing engineering systems, that is different systems but perform similar main functions indicates that Mobile Radiography exists for X-ray generation that is compact and at the same time has mobility. If this parameter is integrated to the fixed radiology, that is have fixed radiology on wheels, though at macro level contradictions exist which can be again taken up using various TRIZ tools such as engineering/ physical contradictions or ARIZ.

Working through the sub trend of engineering systems used in same situation yields that detector and X-ray tube operate in synchronized manner. In short, further development would mean that both will be connected in the future to save time and cost. This also comes up with other sub trends such as integrating inverse engineering systems performing opposite functions.

From sub trend 2, studies of integrating heterogeneous engineering systems which means to identify engineering systems that utilize shared resources though they cater to different main functions, it is found that ultrasound systems or X-ray systems would need the following shared resources: Room, workstation and radiologist.

Studies of further sub trend based on deeper integration, indicates two main directions:

- Merge ceiling suspension system to the mobile system and trim ceiling suspension completely
- Within engineering system, merge wall stand to ceiling suspension

2.3.4 Trend of increasing coordination

Identifying identical rhythms indicates that Detector and X-ray tube have a common rhythm of alignment. This also again complements the results from the trend of super system stated above in 2.1.2.3.

From the material analysis, using composites for telescopic arm will help to take more load with lesser self-weight.

2.3.5 Trend of increasing controllability

One of the sub trends of this trend indicates that as engg. system evolves, level of control within engg. System increases from Uncontrolled system to Fixed program to externally controlled system to self-controlled system.

Currently the DR systems is externally controlled system. Analyzing basis this trend, indicates that with a similar analogy as that of target seeking missiles, target seeking X ray would soon be a reality. Patient waits at one spot and X ray tube and detector will automatically adjust based on the patient anatomy X ray that needs to be taken.

Analyzing sub-trend 2, as engg. System evolves, the number of controllable states increases. Currently the catch positions used to park the ceiling suspension at particular locations are discretely controlled and this would move to continual catch.

2.3.6 Trends of Increasing Dynamization

Sub Trend of Design Dynamization [6] indicates that telescopic arm and rails be linkages, elastic/ hydraulic or gaseous and table that is currently fixed (top base), can be made flexible like in Dental Table.

2.3.7 Trends of Decreasing Human Involvement

Transfer of control function: Using intelligent algorithms for alignment of patient and Ceiling (AI development) would soon be a reality.

3 Results

The following is the outcome of the TRENDS study for the MPV's of compactness and workflow improvements:

3.1 Compactness:

- Reduction of layout space would be the key to achieve compactness. Currently DR systems have multiple portfolios, such as mobile radiology and fixed radiology (ceiling suspension units). Both have similar function with varying needs and unique features. However, if the required contradictions are considered as the problems to solve for future, current portfolio

can be reduced to single systems with advantages of both. Refer Figure-5. In short, the trends suggest that DR portfolio would move to ceiling suspension on wheels. This would include generator sharing as required for higher Kv, etc.



Fig. 5. Adapting a single portfolio

- Mechanical integration of Bucky unit with X-ray system would soon be a reality.
- Usage of composites for larger load capacity and lesser weight for components within ceiling suspension.

3.2 Workflow Improvement:

- Target seeking X-ray mechanics developments reduces patient alignments time improving workflow and utilization of AI for easy diagnostic capabilities.
- Flex-Table like in dental tables - trimming wall stand completely.
- Short term: Easy ergonomic movements.

4 Conclusions

The method of MPV, S-curve analysis and TESE ensures that there is a methodical way that provides new insights on how future developments envision the next generation medical device in Digital Radiology segment and the same is applied practically to the Ceiling suspended devices through this case study.

Acknowledgements

I would like to thank Mr. Radhakrishnan Kodakkal, Sr. Director, R&D, Digital Radiology for encouraging me to constantly apply innovative methodologies like TRIZ effectively in Philips.

I would like to acknowledge the constant motivation and valuable guidance of TRIZ Master, Dr. Sergei Ikoenko, provided throughout the development of this case study. His expert guidance helped me to effectively apply and connect the right TRIZ tools to the actual product.

I would also like to thank Mr. Tito Kishan Vemuri, TRIZ expert for his constant encouragements in coming up with this case study to envision the forecast of medical devices.

References

1. About Philips: <https://www.philips.co.in/healthcare/about/philips>
2. Market Report of Digital Radiology: <https://www.marketsandmarkets.com/Market-Reports/digital-x-ray-market-1164.html>

3. Market Outlook in Digital Radiology: <https://www.signifyresearch.net/medical-imaging/positive-outlook-digital-radiography-market-2018-will-last/>
4. Market Trends in Digital X-Ray systems: <https://www.business-wire.com/news/home/20160914005021/en/Top-3-Trends-Impacting-Global-Digital-X-ray>
5. Dr. Sergei Ikoenko “TRIZ Level – 3 Training Material”, 2018.
6. Victor Fey and Eugene Rivin, “Innovation on Demand – New product development using TRIZ”, Cambridge University Press, 2005.

Communication

Communicating Author: srinivas.peddi@philips.com, peddisrinivasr@gmail.com

TRIZfest 2019

September 11-14, 2019. Heilbronn, Germany

FUNCTION ANALYSIS FOR CONVERT SYSTEM

Yong Joon Lee

Hyundai Motor Company, Seoul, Korea

Paper Classification:

- TRIZ-related methods and tools development

Abstract

The function analysis with clear rules is very useful for the analysis of failure modes, effects and causes for systems in vehicle. There are many status change systems in the car. These systems convert the raw state component to the changed state component. These systems are called convert systems. This paper exemplify how components are presented and how they are helpful in expressing functions in the convert systems.

1 Systems in the Vehicle

The attributes that are developed in the automotive industry are diverse. Technologies applied in the automotive industry are not only mechanical systems but also various devices such as sensing devices, energy conversion, material state transformation, control devices and software, and new material systems.

The system that the author wants to describe is the one that convert input element into output element of different state.

In the automotive industry, where quality issue is the top priority in vehicle development, the activity of predicting is very important to analyze the causes and effects of failure modes to establish appropriate measures to prevent quality problem. This is especially important for systems related to safety issues and regulations. In addition, these systems usually have the technical characteristics of the status change.

1.1 Convert Systems in the car

The automotive industry that controls and consumes energy makes use of many status change systems, or in other words, convert systems. Emission control system, electronic controller of the vehicle is also kind of a converter. The features of these convert systems have input and output components. Some examples of such a convert system are as follows:

- Oil pump: change the hydraulic energy level
- ECU: change the information

- Catalytic converter: change the raw exhaust gas state
- Air cleaner: change the dust status from raw air
- Inverter: change the electric current state

1.2 Failure mode-effect-cause of convert system

In the automotive industry, failure modes are defined as malfunctions of system functions. A failure effect is defined as the consequences of a failure mode of the object component. A failure effect is the failure state of the target system or the problem state from the customer's side as a result of failure mode of the system. In other words, to analyze the effects, the error state of the object component must be analyzed. Then, we can determine the severity rating for the failure mode of the system based on the failure effects.

Failure causes should be analyzed from the system components itself and/or the system surrounding components.

2 A Function Model of Convert System

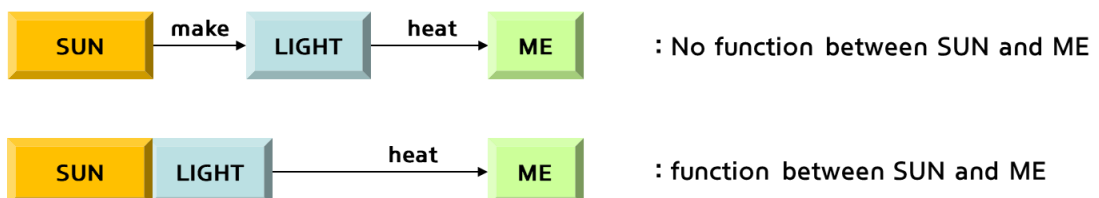
A correct function model is required for the correct analysis of the failure mode-effect-cause of the convert system. If misunderstandings and errors of the function model of the convert system occur, the result of the analysis will inevitably be wrong. In this respect, the correct expression of the convert system is very important.

2.1 The Sun and Me

In order for a function to exist between the sun and me, the sun and I must be components which interact, and as a result, change or maintain the parameters of the target or object component.



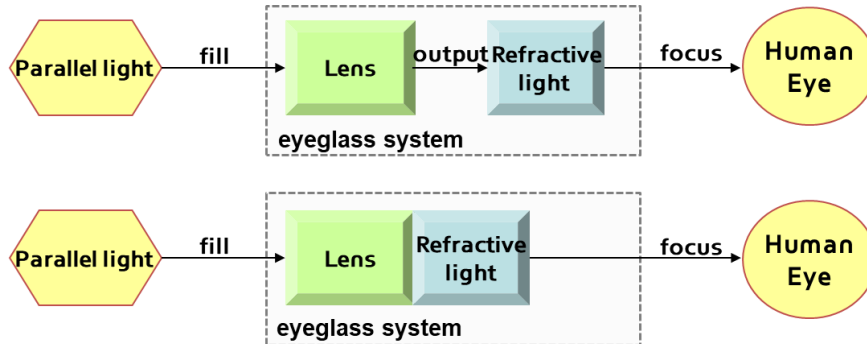
Whether a function exists between the sun and me depends on the perspective of determining the nature of the sun. Of course, there is no function between the sun and me if we look at the sun's attributes by itself except the light. However, if you look at the sun and the light as the nature of the sun, there is a function between the sun and me, and it can be shown like below.



2.2. Target of eyeglass system

Many people whom I have experienced think the object component (target) of glasses is light. If the light is intended to be the target of the eyeglass system, failure of the effects of eyeglass as a result of failure should be found in the light. However, for so many light in the world, eyeglass do not change the light itself, so this failure effects analysis become troubled situation.

The eyeglass system is also one of the convert systems. Parallel light becomes an input element from the system, and refractive light comes out as an output element of it. It is similar to the light coming from the sun. In this case, the eyeglass system and the refractive light are modelled as follows and the object component (target) becomes the human eye. The effect of the failure mode of the eyeglass system can now be found in the human eye condition.

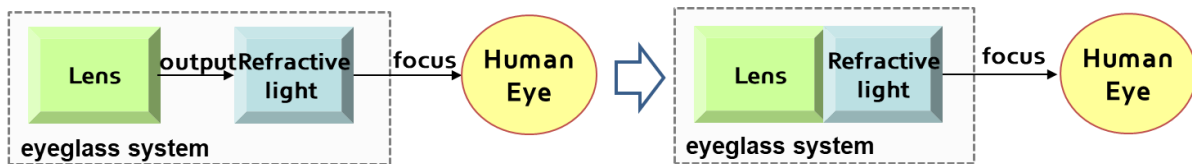


Refracted light should be a component that can be controlled by the eyeglasses system and must be responsible for it. Then we can summarize the failure mode-effect-cause of the eyeglasses system as follows:

- Failure mode: The refractive light of the lens cannot focus on the eye correctly
- Failure effect: Human cannot aware of visual information (poor eyesight, eye pain)
- Failure cause Lens do not output correct refracted light (Lens deformation)

2.2 New approach to the Convert System

In the actual analysis example, a function model may be made to function as a target by deriving the refracted light marked by an independent system component, but it may be more useful in the simple representation of the extended lens light component by combining the deflected light with its light.

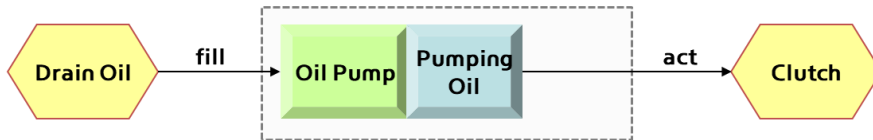
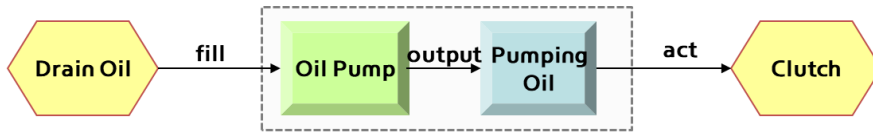


3 Application to the Convert System of Vehicle

The following are some examples of the convert system applied to the car.

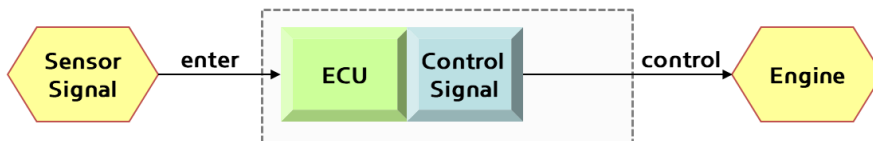
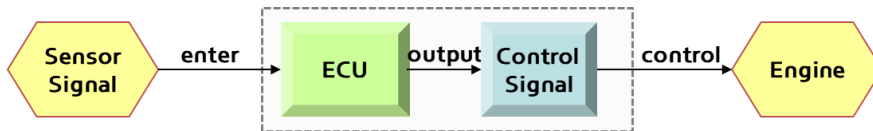
3.1 Some cases of Convert System of Vehicle

1. Oil Pump: change the hydraulic energy level



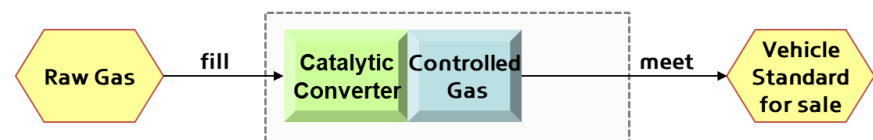
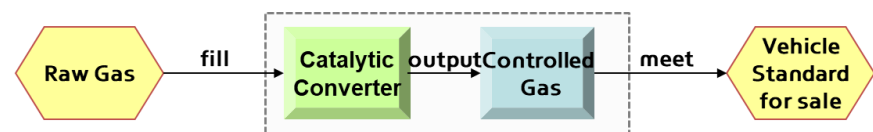
- Failure mode: Oil pump oil cannot act clutch
- Failure effect: Clutch cannot connect engine power to transmission
- Failure cause: Oil pump do not output sufficient oil flow

2. ECU : change the signal information



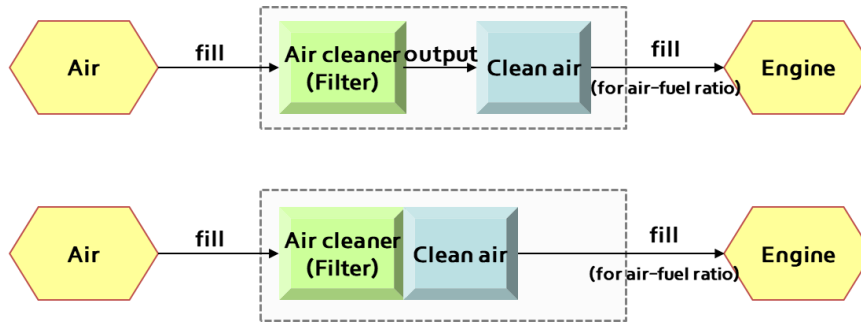
- Failure mode: The ECU signal cannot control the Engine
- Failure effect: Engine cannot make power
- Failure cause: ECU do not output correct control signal

3. Catalytic converter: change the raw exhaust gas state



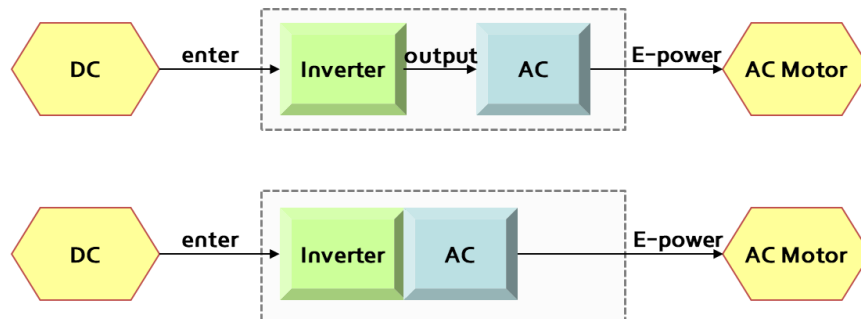
- Failure mode: SCR Gas cannot meet the Vehicle standard for sale
- Failure effect: Vehicle cannot be sale
- Failure cause: SCR do not output correct Low gas

4. Air cleaner : change the dust state from raw air



- Failure mode: A/C air cannot meet ratio of air-fuel of engine
- Failure effect: Engine cannot make max power
- Failure cause: A/C do not output clean air

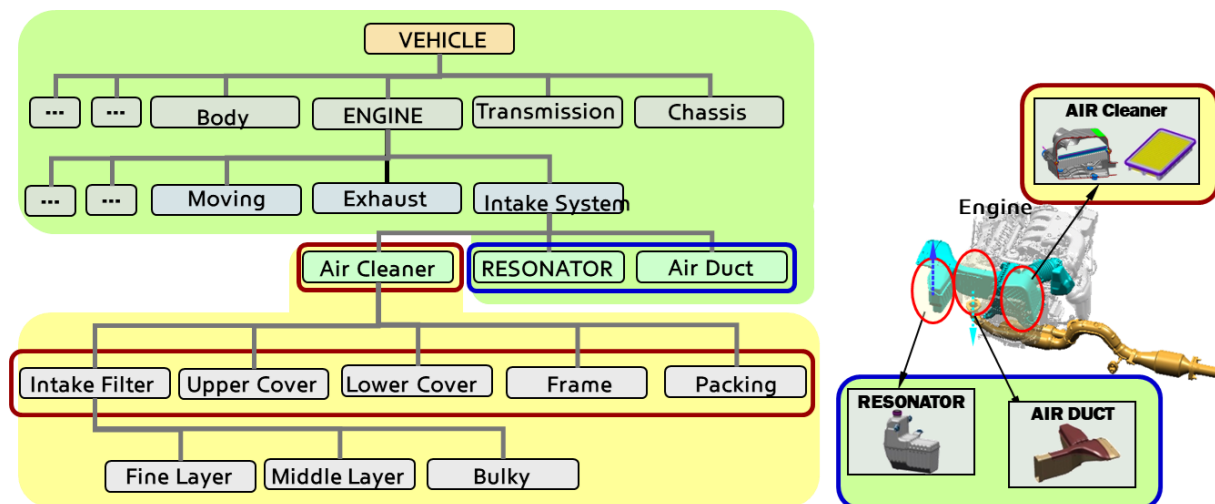
5. Inverter: change current state



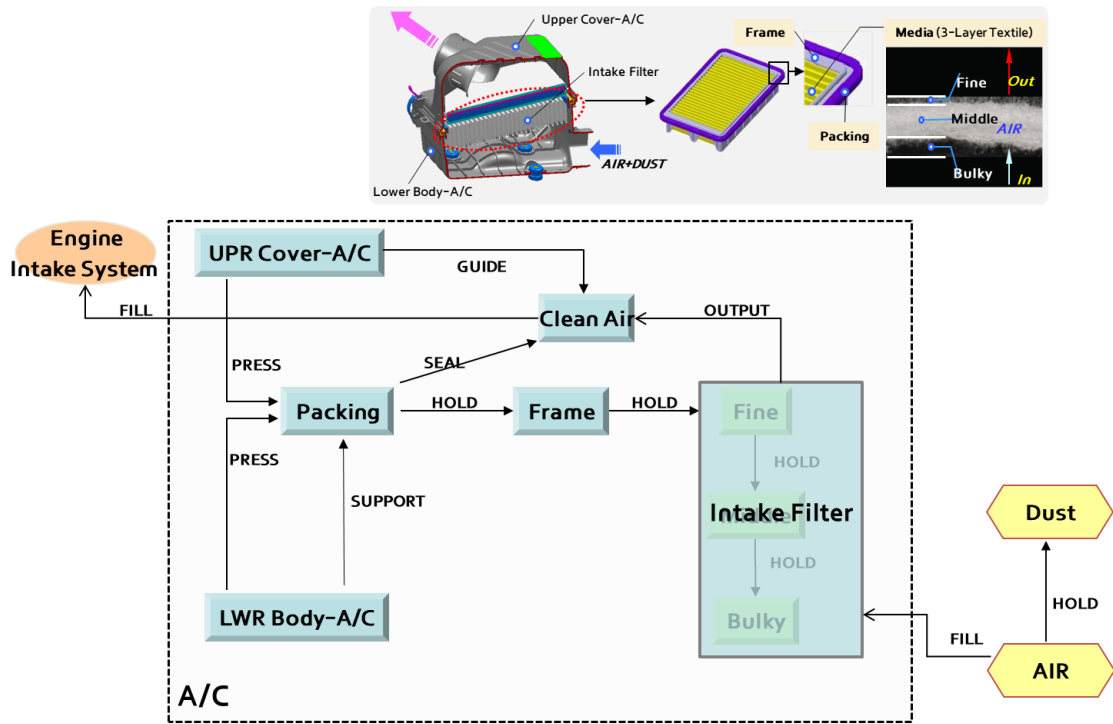
- Failure mode: Inverter AC cannot e-power the AC motor
- Failure effect: AC motor cannot make power
- Failure cause: Inverter cannot output AC

3.2 Function Model of the actual system in vehicle

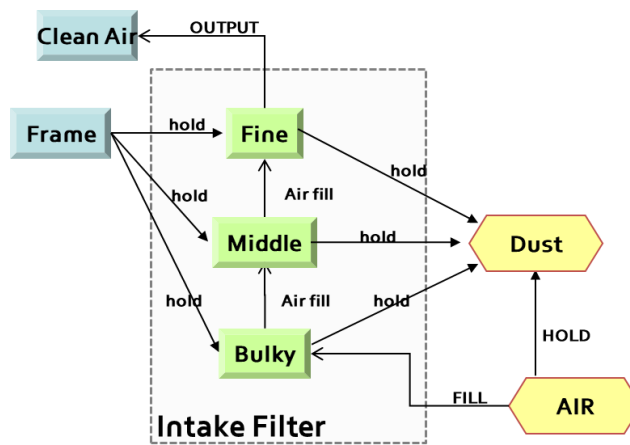
As an example of the application of this paper, the Air Cleaner function model, a sub-system of an automobile engine, can be described as follows:



And Air Cleaner (A/C) system function model is as follows:

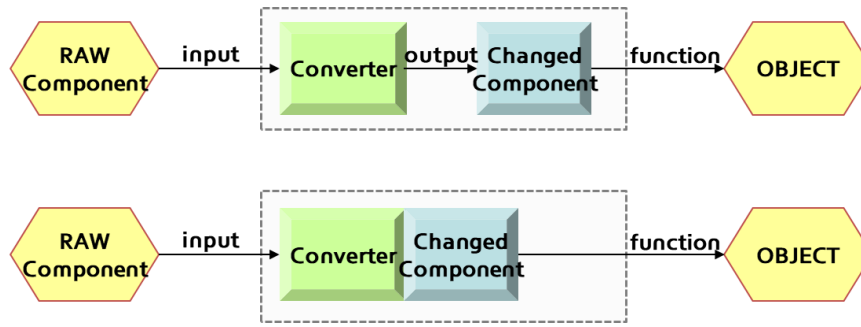


And Filter system function model is as follows:



4 Conclusion of Function Analysis for Convert System

In the case of a system that converts the above-mentioned states, it can be generalized as follows:



- Failure mode: Malfunction from Changed Component to the OBJECT
- Failure effect: Malfunction of OBJECT as the consequences of failure mode
- Failure cause: Malfunction of Converter to the Changed Component (Faults of the Convert System)

The simplified, combined components function on target as a system component and it can be properly analyzed for failure mode-effect-cause according to the state of this function. These function models will be a very effective tool at the FMEA as next step.

References

1. Carl S. Carlson, "Effective FMEAs", John Wiley&Sons, 2012.

Communication

Communicating Author: leeyongjoon@naver.com

TRIZfest 2019

September 11-14, 2019 Heilbronn, Germany

HOW TO BRING THE SUCCESSFUL CONCEPT OF TRIZ TO SMALL AND MEDIUM-SIZED COMPANIES AND TO SUPPORT THEM DURING THE IMPLEMENTATION OF TRIZ

Dr. Stefan Engelhard^a, Anne-Kathrin Kiesel^a, Dr. Robert Adunka^b

^a*IHK Reutlingen, Reutlingen, 72762, Germany*

^b*TRIZ Consulting Group GmbH, 92237, Germany*

Paper Classification:

- Educational methods and experiences

Abstract

The Institute for Knowledge Management and Knowledge Transfer of the Reutlingen Chamber of Commerce and Industry (IHK-IWW) has set itself the goal to increase the innovative strength of small and medium-sized companies. The learning and application of the innovation method TRIZ is a building block in this effort. TRIZ can be learned, but the professionalized use of TRIZ tools requires step-by-step guidance by experienced instructors and repeated use of it. In general, it is a great challenge to inspire entrepreneurs who are still unfamiliar with TRIZ to work with this method. In addition to learning the theory, another not quite easy step is the successful introduction of TRIZ in the everyday life of the respective companies. The Reutlingen Chamber of Commerce and Industry (IHK Reutlingen) has successfully established TRIZ as an important figurehead of the Neckar-Alb region through its activities in the field of TRIZ training and the continued networking of TRIZ actors. At the end of 2018, more than 150 engineers in the Neckar-Alb region were using this methodological knowledge. The activities are summarized at www.innovation-hat-methode.de. This paper provides an overview of the German IHK system, explains how the Research and Development Network is important to IHK Reutlingen, summarizes how the IHK Reutlingen helps to implement TRIZ in the companies in its region, and how these businesses benefit from TRIZ.

Keywords: *group meetings, coaching, support*

1 Introduction

1.1 Reutlingen Chamber of Commerce and Industry

The Reutlingen Chamber of Commerce and Industry (IHK) represents the interests and service providers of the regional economy and is the central link between business, politics and administration. Through international cooperation, the IHK also represents its members abroad. About 48,000 companies are members of the IHK Reutlingen by law.

The IHK Reutlingen is one of twelve chambers of Commerce and Industry in Baden-Württemberg and one of 79 in Germany. Its umbrella organization is the “Deutsche Industrie- und Handelskammertag e.V.” (German Chambers of Commerce and Industry) (DIHK) in Berlin. Through the representation of the DIHK in Brussels, the IHKs also maintain contact with the institutions of the European Union (EU).

1.2 The Institute for Knowledge Management and Knowledge Transfer

The chamber's own Institute for Knowledge Management and Knowledge Transfer (IHK-IWW) was founded in addition to the transfer facilities at scientific institutions. Based on the needs of the companies, projects and activities are initiated and implemented. In the field of innovation, the Institute is involved in a wide range of technology transfer activities, targeted funding consultancy, the organization of networks such as the textile industry, which is strongly represented in the region, the organization of the ESA BIC Space Startup Centre and the mediation of international contacts via the Enterprise Europe Network, as well as the use of innovation methods in regional companies. Small and medium-sized technology companies in particular benefit from the services offered.

The IHK-IWW is home to various networks:

- Network ‚Innovation‘
- Network ‚Research & Development‘
- Network ‚Production‘
- Network ‚Quality‘
- Network ‚Virtual Power Plant Neckar-Alb‘
- Network ‚Real Time Kinematic Baden Württemberg (RTK-BW)‘
- Network ‚Cluster Technical Textiles Neckar-Alb‘
- Network ‚Security‘
- Network ‚Artificial Intelligence‘

1.3 The IHK networks

A special feature of the IHK Reutlingen is the currently more than 50 different networks, whereby new networks are constantly being founded. Each network has a specific focus, but they all offer a successful platform for exchanging experiences or the opportunity for thematic meetings. The networks also act as intermediaries for contacts between companies in the same or other sectors. The management of the networks and the organization of the network meetings are taken over by the network managers of the IHK Reutlingen.

The TRIZ activities originate from the Research & Development network. However, there are also cross-network events on the topic of TRIZ throughout the year, as innovation methods are becoming increasingly important for companies.

1.4 The Research & Development Network

The Research & Development Network has set itself the goal of creating a platform for constant dialogue between business and science in the Neckar-Alb region, networking member companies at the highest level, exploiting synergies and thereby implementing joint projects. Any medium-sized technology company with its own development department can become a network participant. Participants pay an annual participation fee per company. This means that membership always means corporate membership, so that different employees of a company

can also take part in the various events. The offers of the Research & Development network are divided into various sub-areas. These include the annual Innovation Days (see www.innovationstage.de), a series of events lasting two weeks, two network meetings per year for development managers and the "Innovation has Method" forum, which is home not only to the "Innovation and Best Practice" group but also to the TRIZ specialist groups.

2 TRIZ at IHK Reutlingen

Learning the TRIZ method in a training course is the first step, but using it successfully in the company afterwards is a completely different problem. However, this is crucial for success. In order to gain as much confidence as possible with the use of the TRIZ methods, a lot of practice is required, especially over a longer period of time. Supporting companies in this exhausting introduction of the TRIZ method is a decisive factor for success. How the IHK Reutlingen implements this in practice is described in the following.

2.1 TRIZ Information Events

The IHK Reutlingen offers information events on TRIZ at irregular intervals throughout the calendar year or informs about TRIZ at other IHK events. During these meetings the participants have the opportunity to learn some facts about TRIZ, to learn some tools and to exchange experiences with skilled TRIZ users. This type of event attracts new interested parties to TRIZ.

2.2 TRIZ Trainings

Since 2011 the IHK Reutlingen has offered regularly certified TRIZ trainings according to the concept of the international TRIZ organization MATRIZ. Before that, a user group without the standard was also offered. In 2019, for example, two 4-day courses for Level 1 and a five-day course for Level 2 will be offered. Each training course is concluded with a final examination. The trainings will be held in 2019 by Barbara Gronauer, TRIZ Specialist (Level 4) and Dr. Robert Adunka TRIZ Master (Level 5). Companies that are in the Research & Development network receive a discount on the training fee. The certified TRIZ training courses provide the knowledge and the necessary prerequisites to participate in the various TRIZ groups offered by the Reutlingen Chamber of Commerce and Industry.

2.3 TRIZ Beginner Group

The IHK Reutlingen regularly starts new TRIZ beginner groups to deepen the knowledge in the innovation method TRIZ. In particular, the focus is on the application of the method to the problems of the respective company and the transfer to the company. The monthly all-day sessions are moderated by experienced TRIZ facilitators. Since September 2017, the fourth TRIZ beginner group in a row has been active, which meets monthly for a period of two years. A fifth group is currently being planned. After two years of intensive practice and first assignments in the company, these participants switch to the group of TRIZ experts. Newcomers are always assigned to the TRIZ beginner group. During the two years, up to 20 topics will be discussed in the joint group meetings. One topic is discussed per meeting. The topics will be brought along by the participants from their companies and presented to the group in a vivid way. Since these are often sensitive, company-internal topics, each participant is obliged to sign a secrecy agreement when setting up the beginner group. There are also special rules of procedure which regulate, for example, the exploitation of the results.

After the presentation of the participant, solutions to the problem are worked on in small groups with the help of the various TRIZ tools. Due to the diversity of the companies and the interdisciplinary composition of the participants, the company that provided the topic gets many different suggestions and impulses for its problem. This enables the participants to obtain goal-oriented external opinions on a topic in a protected surrounding.

The group meetings are conducted by the participants themselves. This means that every graduate of the TRIZ level training course has the opportunity to try out the use of TRIZ as a moderator in the TRIZ beginner group. During the meetings, an experienced TRIZ specialist is available to answer all the participant's questions and to aid in case of difficulties with the various TRIZ tools. In the fourth group, this is Dr. Robert Adunka. The participants can thus conduct their own workshop outside the company and avoid beginner's mistakes during the introduction of TRIZ in the company. The aim of these groups is to remove the uncertainty for TRIZ users and to support them in the introduction of TRIZ in companies. This type of efficient exercise time and mutual motivation is a very suitable method for this.

At any time during the meetings, it is possible to exchange experiences with the application of TRIZ in the companies and to get tips from the other participants.

The two-year collaboration between all the actors creates a very pleasant and relaxed atmosphere during the meetings, which enables the participants to have more confidence in acting and to become even more involved in the creative work.

By the end of 2018, more than 60 participants had already passed through the TRIZ beginner groups.

Such group meetings would not be possible without the IHK Reutlingen, because all management expenses incurred by the group are carried out by an employee of the IHK. For the Reutlingen Chamber of Commerce and Industry, the networking of TRIZ users and the regular range of exercises are the key to the successful implementation of TRIZ in companies.

2.4 The TRIZ Experts

On average, ten TRIZ experts (TRIZ Level 2 or higher) are involved in the group activities. The group of TRIZ experts meets three times a year, attends national TRIZ meetings, sets its own standards and supports the regional universities Albstadt-Sigmaringen and Reutlingen in teaching TRIZ in lectures. At the group meetings, each expert has the opportunity to report on his or her current activities and progress. This makes it possible to track the TRIZ activities of the individual TRIZ experts. Above all, however, the focus is on the exchange between companies. Participants also have the opportunity at any time to contribute their own ideas and express their wishes for upcoming events.

2.5 Organization / Management of TRIZ Meetings

The management and the competent support of the TRIZ-groups will be taken over by an employee of the IHK-IWW.

TRIZ beginner group: The dates of the meetings are already fixed when the group is founded, so that a regularity can arise for all participants and the no-show quota remains as low as possible. The location of the meetings consists exclusively of rooms of the IHK Reutlingen, so

everything takes place on "neutral" ground and the actors do not feel distracted from their familiar surroundings. The central location of the IHK Reutlingen makes it easy for all participants to get there.

TRIZ experts: The dates of the meetings are coordinated with the participants and various topics are determined. How the meetings take place is determined after consultation, mainly by the participants themselves. The locations can vary on request and can also be carried out in local companies.

2.6 Outlook

After the end of the TRIZ beginner group 4, the foundation of another TRIZ beginner group is planned. A TRIZ Highlight event took place in March 2019. On this date different possibilities were shown, which are available after level 3. On this day, everything revolved around the company's own further developments and new developments of the TRIZ tools. The participants also gained insights into the TRIZ activities at Robert Bosch GmbH.

Another major goal of the IHK-IWW in the field of TRIZ will be the integration of the method into the textile industry, especially in the Neckar-Alb region. The integration of TRIZ into the textile industry is being carried out under the "Place2Tex" project of the Südwesttextil e.V. association, sponsored by the Baden-Württemberg Ministry of Economic Affairs, Labour and Housing. This is about the professional support of textile companies in innovation-specific topics. The task of the IHK Reutlingen is to communicate the innovation method TRIZ.

In addition to TRIZ, other methods, such as design thinking, are also included in the services offered by the Reutlingen Chamber of Commerce and Industry.

3 Result

The various services offered by the Reutlingen Chamber of Commerce and Industry have led to more than 150 engineers in the Neckar-Alb region currently working with TRIZ methods. In addition, more than 60 participants have already successfully passed through the TRIZ beginner groups and are still active. It is pleasing to note that the demand for training courses, events and the TRIZ groups remains very high. The participants of the TRIZ beginner groups regard the offer of the IHK Reutlingen as very successful and would recommend it to others. During each meeting of the closed TRIZ groups an average of 100 new ideas were generated. This means that over the past time a number of almost 7000 new ideas were created. The number of resulting patents cannot be published. Since the ideas go directly to the clients at the end of the group meetings, there are no further documented results.

4 Conclusions

The IHK Reutlingen with its own Institute for Knowledge Management and Knowledge Transfer (IHK-IWW) is on the road to success in TRIZ. The various offers for the TRIZ method are well received by small and medium-sized enterprises. TRIZ is a great opportunity for the Neckar-Alb economic region. Especially at the beginning of the introduction, companies need support beyond the normal seminar offers. The IHK Reutlingen provides this support through various working groups and thematic meetings.

References

www.innovation-hat-methode.de

Communication

Communicating Author: engelhard@reutlingen.ihk.de

TRIZfest 2019

September 11-14, 2019. Heilbronn, Germany

INCREASING OF CUSTOMER EXPERIENCE WITH VACUUM CLEANER USING THE TRENDS OF ENGINEERING SYSTEM EVOLUTION

Vladimir Sizikov^a, Markus Gabor^b

^a*Robert Thomas Metall- und Elektrowerke GmbH & Co. KG, Neunkirchen, D-57290, Germany*

^b*innovation.rocks consulting GmbH, Vienna, A-1030, Austria*

Paper Classification:

- Best practices, business experiences, integration with non-TRIZ methods/tools
- Case study

Abstract

Robert Thomas is a family-owned medium-sized German company. The company develops, manufactures and distributes vacuum cleaner under THOMAS brand for special markets and/or target groups. Two main target groups are pet owners and allergic sufferers. One core know-how is in the filtration technologies (see Fig. 1).

Keywords: TESE, VR/AR, vacuum cleaner, customer experience

1 Project

1.1 Product and technology description

Robert Thomas is a family-owned medium-size German company. Under THOMAS brand the company develops, manufactures and distributes the vacuum cleaner for niche markets. The main target groups are pet owners and allergic sufferers. The core know-how is in the filtration technologies (see Fig. 1):

1. Aqua-FreshAir-Box uses water as a filtration medium. Dust particles, as well as odors are “showered” within the filter unit and caught in the water. Ambient air is refreshed with a small part of humidity.
2. easyBox uses dry cyclonic separation in two steps. Hairs and coarse dust are caught in the main chamber. Fine dust is extracted and transported to the side chambers. By emptying of the main chamber there is no dust released in the air (so-called “dust cloud”).

Both filtering boxes have the same interface and can be used in the same vacuum cleaner, replacing each other.



Fig. 1. THOMAS filtration technologies for vacuum cleaner

1.2 Problem and goal of project

The main challenge is to communicate the advantages of the filtration technologies to target customer groups. Both in retail and online THOMAS is dealing with the following problems:

1. Generally vacuum cleaner is a low-involvement product. 70% of European customers buy the new device when the old one is not functioning anymore, without spending any effort for analysis of product information [1].
2. There is a strong competition from the low-cost segment.
3. Filtration technologies are not visible at the appliance on the retail shelf.
4. State-of-the-Art online content (pictures, banners, videos, etc.) can't visualize the filtration technologies. Also as mentioned above, the end-customer is not attracted to look all the content.

The main goal of the project was to find new long-term solutions for marketing, which can easily explain the product advantages, differentiate the company from competitors and attract customers to look the product information. Ideal final result is defined as: high marketing effect with low cost.

1.3 Relevance of Virtual and Augmented Reality

As described in the chapter 2 below, virtual and augmented reality (VR/AR) were identified as relevant visualization technologies to solve the problem. Though the importance of VR/AR is growing, the most applications are still new on market and in many cases didn't reach the technologic maturity yet. Also not all expectations from the market side are fulfilled (see Fig. 2).

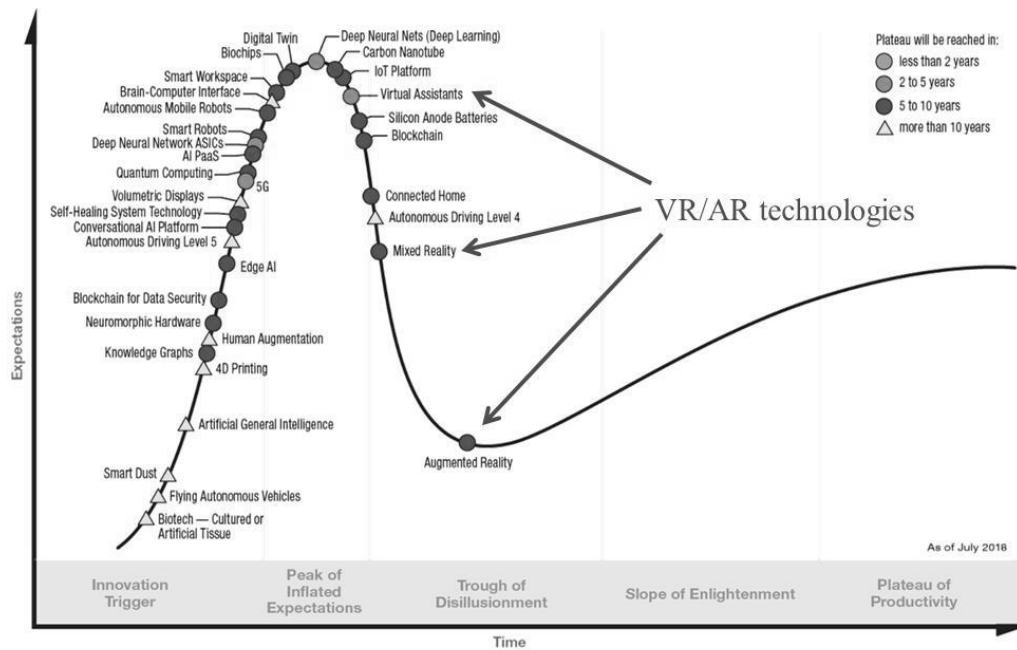


Fig. 2. Gartner Hype Cycle for emerging technologies 2018 [2]

It means that additional task for the project is to make a technology forecast for development of VR/AR and to define the right implementation strategy. This task was accomplished in cooperation with innovation.rocks consulting GmbH. The company provides full service in development and implementation of VR/AR technologies for different applications.

2 TRIZ relation

During the project following TRIZ-tools were applied:

1. Function modelling for the problem analysis
2. Engineering contradictions and contradiction matrix for the problem solving
3. Trends of Engineering System Evolution (TESE) to forecast the development of VR/AR and define the right strategy for THOMAS

2.1 Functions models for retail and online shops

Because the product communication takes place in two different areas, retail and online, function models were elaborated for the both cases, see fig. 3. The target component is always the Customer. Here we need to fulfill two functions: attract (customer's attention to the product) and inform (the customer about the product). The analysis showed, that the function "attract" is better (though insufficient) fulfilled in retail, e. g. through product design, while the function "inform" is realized more through the online content (e. g. product videos). The new solution for product communication must at least strengthen these two functions. Ideal final result is defined as a concept, which is applicable in both cases, retail and online.

In retail competitor products attract more customer attention through cheaper prices. For the online area big competitors achieve more success through very cost-intensive measures, e. g. permanent online marketing campaigns. The main outcome from the functions analysis was

identification and understanding of the functions “attract” and “inform”. It helped to formulate later the specification for VR/AR-concept.

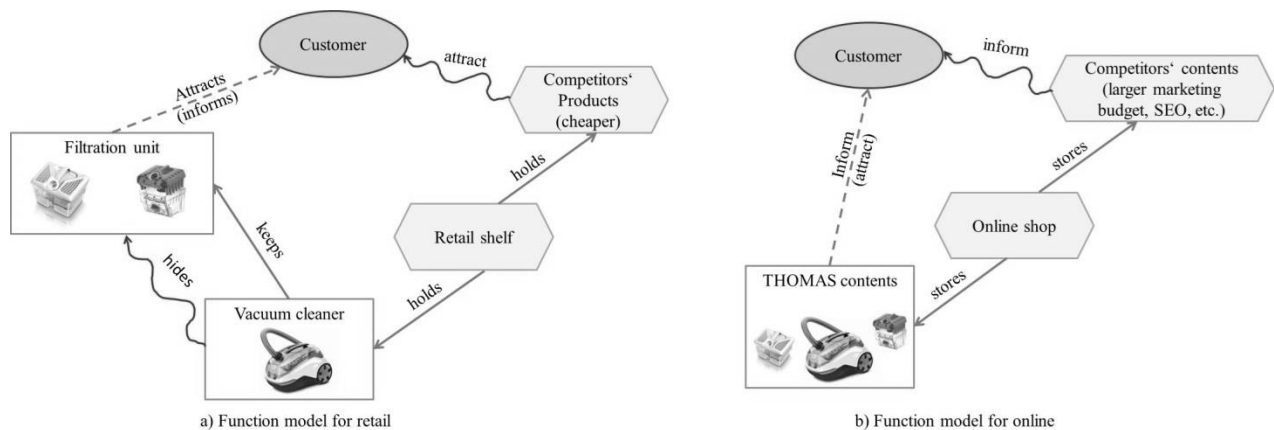


Fig. 3. Function models for product communication

2.2 Engineering contradictions and problem solving

During the project it was decided to prioritize the function “attract”, though “inform” was still in focus. As it can be seen at the figure 3, the function “attract” is performed insufficiently. The filtering functions are not seen inside the device. So the obvious solution would be to visualize the functions, as it is typically done in advertisement: flyers, posters, videos, etc. But this solution means high marketing costs, which are increasing significantly, if the company wants to attract more potential customers. The advantage and disadvantage of product visualization were described in following contradictions:

1. Retail-Contradiction
 IF we bring more visualization for Filtration Unit (e. g. Posters and Videos at point of sales),
 THEN we show the filtration to customer (and attract the customer),
 BUT we increase the effort for installation at the retail shelf
2. Online-Contradiction
 IF we generate high-grade online-content (e. g. with testimonials),
 THEN we attract the customer (and get the chance to show him the filtration)
 BUT we increase the marketing costs

In further discussion considering the offline and online content (it should be more, better, have higher, attractivity etc.) and doesn't bring much effort (it should be less and simpler) the project team came to the conclusion, that content should not demand the resources of the retail or be easily integrated into the existing infrastructure. Here are some of the ideas according to the TRIZ inventive principles (IP):

1. Usage of VR/AR (IP 26 “Copying” – using the optical copy of a system)
2. lighting/illumination of the appliance itself (IP 32 “Changing colour” – illumination to attract the customer to device)

3. solutions for mobile devices of the customer. Additional content can be accessed through so-called hot-spots at the appliance, poster or the package, e. g. QR-code at the cartilage, which forwards to the demo video (IP25 “Self Service” – use customer’s smart phone as a component from the super-system).

VR/AR-solution was prioritized, because it can deliver the necessary functions both for retail and online. Also the content can be accessed by different ways (QR-code, App-Download, Browser-Link, etc.), which makes it flexible to integrate in the different super systems. Also this kind of visualization technology is not state-of-the-art at the whole market yet. It mean that VR/AR is attractive for the end customer because of its newness.

As mentioned in the chapter 1.3 above (see also fig. 2), VR/AR technologies are still in development. That’s why the right strategy is needed in order not to get in the technologic dead end.

2.3 Technology forecast for VR/AR and THOMAS-offensive Augmented Reality

TESE were developed to forecast the evolution of engineering systems [3]. The topic of the present paper is an issue of marketing. That’s why the project team needed to “translate” the meaning of TESE for non-engineering task. Historical analysis of the product communication showed, that the visualization technologies follow the trend of increasing dynamization. In this case the customer interaction with retail and online contents was dynamized during the time. As shown at the fig. 4 the product communication used firstly text as an interaction tool with the customer (e. g. advertisement in first newspapers or at the beginning of internet era). Later pictures (posters) were introduced. The customer got chance not only to read the text, but also go through the more visualized information, for example by looking through the picture galleries (in retail or online). Further dynamization of the content came with video formats. Here the user can not only look the content, but also control it (scrolling forward, backward or stopping the video).

During the last years the growth of more interactive content (in comparison to common videos) was observed. For example 360-degree-videos (started 2015 by Youtube and spreading through all channels in 2017-2018) or development of HTML5 technologies and WebGL-Format (interactive content).

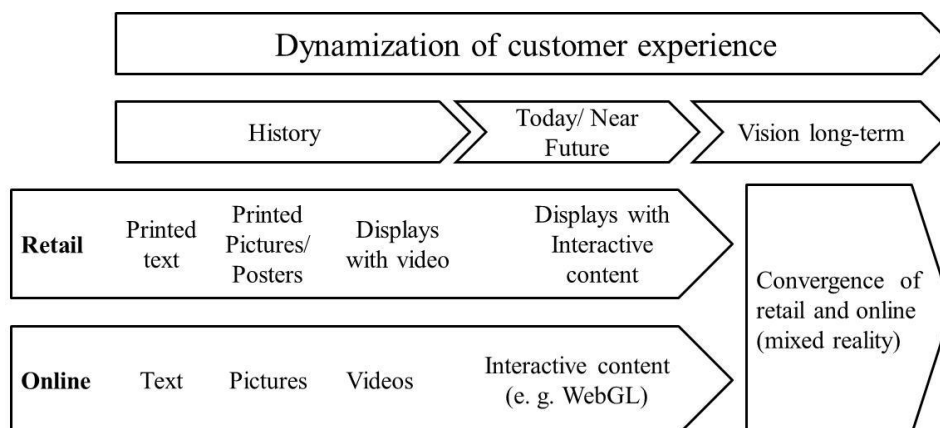


Fig.4. Short summary of technology foresight for customer interaction in retail and online

The project team assumed that in the future the customer interaction in retail and online will experience the convergence in mixed reality. For example, the customer, using his mobile device (in future data-glasses or similar AR-device) can scan product and get any information he needs in form of interactive visualization:

1. Functions of the product,
2. users guide,
3. help for trouble shooting,
4. replacement of spare parts.

An important result of technology forecasting is the hypothesis about convergence of retail and online visualization. It means that the visualization format should be applicable for both areas. This requirement was added to the specification. Main outcomes from application of TESE for the company are:

- Double-track strategy – same marketing contents must be applicable both in retail and online.
- Short-term compatibility with existing systems – VR/AR devices didn't still reach the market maturity. But the applications for smartphones, tablets and other existing devices possible.
- Long-term compatibility with new systems – relevant hardware and data-formats, which are in development now, were identified. Depending on the market penetration of different technologies (e. g. WebGL), it is possible to develop contents today, which would be compatible with the systems in the future.

Details for the company's strategy see in the chapter 3 below.

2.4 Discussion about the relevance of the Trend of Decreasing Human Involvement

Trend of Decreasing Human involvement says that the number of engineering system's function performed by human will decrease, while system is evolving [3]. This trend contradicts to the finding, described in the chapter 2.3 (increasing of customer experience). The authors suggest that there is difference for the role of human these cases. When dealing with customer experience, the Human is a target component of super system. It means, that the function "attract" is the Primary Useful Function. Increasing it through user experience we increase the value of our engineering system. The decreasing of human involvement applies to cases, where the Human is part of engineering system, which can be replaced by non-human component, for example computer.

Nevertheless this trend provides ideas for evolution user interface. Today most customers "operate" the mobile devices (smart phones, tablet, later AR-glasses). In the future these devices can be replaced by voice recognition or other technologies.

3 Results

3.1 THOMAS-offensive Augmented Reality

Product 3D-data were used for the both application areas, retail and online. The data were enhanced with graphic and applied in a WebGL-model for integration in websites [4], as well as

in the augmented reality app, which recognizes the vacuum cleaner and demonstrates virtual filtering units at the real object. For both cases there are hot/spots, allowing the customer to switch between the filtering technologies or perform other actions. The project results (Stand Oct. 2018) are summarized in the fig. 5 below.

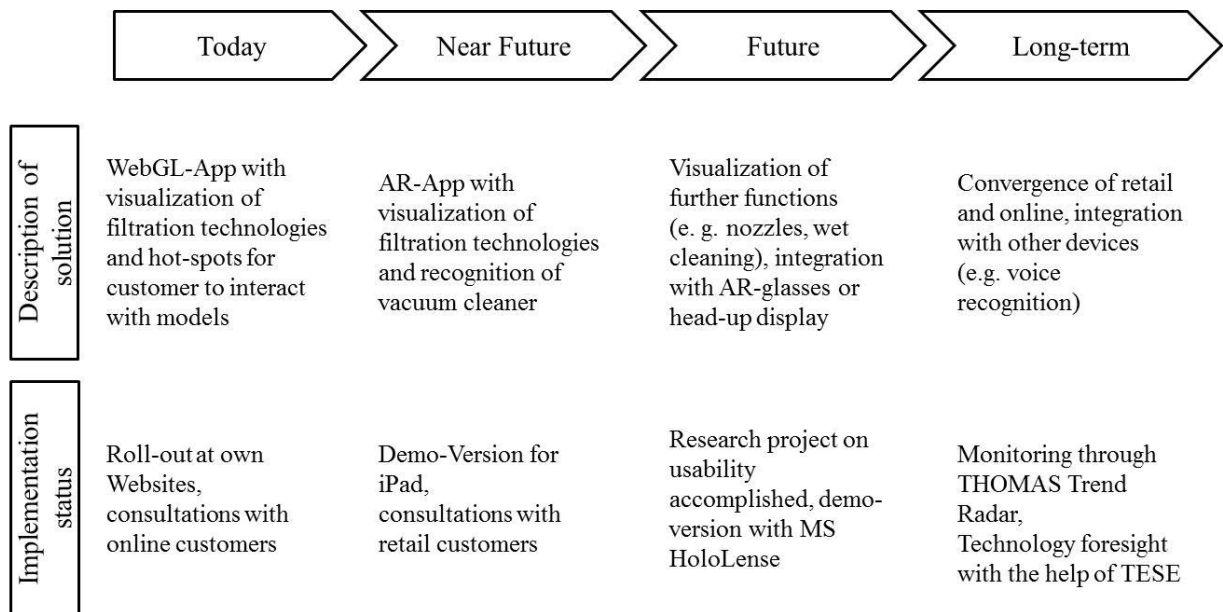


Fig.5. THOMAS-offensive Augmented Reality

3.2 Market feedback and limitations for VR/AR today

Both apps were positively met by customers and distribution partners at the IFA-2018 exhibition. Though there are some technological challenges for the implementation of the visualization:

1. WebGL is a cross-browser format. All main players on market are taking part in development of WebGL. Though uptodate this format doesn't work with al browser versions (e. g. Internet Explorer).
2. The interactive visualization demands computing capacity and graphics from the device. So there are limitations for opening the model at most smartphones (weak CPU and graphic).
3. The interactive content is still unknown. Some test-users expected to see video and didn't wait, that they could actively control the visualization (through hot-spots, rotate and zoom).

The project team assumed, that the interactive contents is now at first or transition stage of the S-curve [3]. Most problems will be solved in the future, for example market penetration of WebGL-format or development of new mobile devices, which can work with augmented reality. For today application there were defined several measures, e. g. demo-videos, as a common format, showing the advantages of interactive models.

4 Conclusions

TRIZ helped to structure the collected information, to make a problem analysis and to define the right strategic goals for implementation of customer experience with THOMAS-products. As described in previous chapter, each part brought valuable outcomes:

1. Function model helped to understand the interaction of product and customer. The functions “attract” and “inform” were identified and analyzed. Results were used in the development of interactive visualization.
2. Engineering contradictions and inventive principles helped to understand the specific problem better, to see the difference between retail and online (considering the visualization) and to generate ideas.
3. TESE helped in the most important part of the work, answering to a question of how the VR/AR-technologies can be useful especially for the company. It helped to explore the possible development directions and to define the THOMAS-offensive Augmented Reality. Also the forecasting make it possible to develop contents, which can be later integrated in new systems in the evolutionary way. It will decrease the needed effort and investments both in short- and long-term perspective.

References

1. Meerschaert, T., Davidson, R., Mikulenaite, U. „Vacuum cleaner usage and attitudes“, CECED Vacuum Cleaner Research, 2018.
2. Gartner Hype Cycle for emerging technologies, Juli 2018, <https://www.gartner.com/smarterwith-gartner/5-trends-emerge-in-gartner-hype-cycle-for-emerging-technologies-2018/> (accessed on 20.03.2019).
3. Lyubomirkiy A., Litvin S., Ikovenko S., Thurnes C., Adunka R. “Trends of Engineering System Evolution”. Nuremberg, Digital Print Group, 2018.
4. Example of WebGL-model, intergrated in the product site of THOMAS: <https://www.thomas.ua/cgi-bin/p.cgi?a=grp&g=171>

Communication

Communicating Author: v-sizikov@robert-thomas.de

TRIZfest 2019

September 11-14, 2019. Heilbronn, Germany

INNOVATIVE DESIGN OF THE ANTI-EROSION STRUCTURE IN A WATER HYDRAULIC VALVE BASED ON TRIZ COMBINING WITH BIONICS AND FRACTAL THEORY

Yonghui Zhang, He Xu, Haihang Wang, Siqing Chen, Zitong Zhao, Vishwanath Pooneeth

*College of Mechanical and Electrical Engineering, Harbin Engineering University,
Harbin, 150001, China*

Paper Classification:

- Case study

Abstract

The throttle valve remains a key component in the water hydraulic system due to its high endurance and reliability. However, in certain working conditions, the water flow mixes with solid particles such as sand, resulting in serious erosion of the valve in turn affecting the hydraulic system's performance. To improve the erosion resistance, an innovative design method integrating TRIZ, Bionic, and Fractal was presented. Combining TRIZ with bionics, suitable bionic objects were investigated and an extensive model of multi-factor coupling bionics was built to analyse the Coupling contribution. TRIZ and Fractal theory were applied to qualitatively and quantitatively illustrate the structure of the Discrete Phase Model from the ANSYS Fluent tool, which was used to numerically model the anti-erosion performance of the bio-inspired valve. Then, the water hydraulic experiment platform was used to validate the simulation. The results showed that the novel valve structure had a positive effect on erosion resistance, which demonstrated the feasibility and effectiveness of the innovative design method.

Keywords: *Water hydraulic valve; TRIZ; Bionics; Fractal; Anti-erosion*

1 Introduction

As a part of the hydraulic system, a throttle valve always operates at high pressure and in full flow. Although its main function is to control the fluid flow, it can also be integrated with other valves to other perform specific functions. There two main factors affecting the life of a water hydraulic valve are cavitation occurrence at the orifice and erosion of the valve core. The first case mostly happens in a vessel system under big pressure difference. While the second one mainly occurs in high flow rate systems. In previous studies, researchers have used methods the following methods: changing the materials of samples, applying coatings, and performing surface treatment [1, 2]. However, the traditional approaches did not only increase the anti-erosive performance of surfaces, but they also raised the difficulty and price in the manufacturing process. Currently, there is a growing interest in micro-structure-engineered surfaces in engineering fields. Especially, bionic surfaces inspired by plants and animals have become a

highlight in recent years such as the self-cleaning microscopic surface structure of lotus leaves [3], just to name a few.

As shown in Fig 1. TRIZ is used to solve engineering contradictions and guide the search for biomimetic models in this paper. A marine mollusc termed as the conch was considered through analysis. The convex non-smooth structure and spiral curve on the surface was found to have a certain erosion resistance quality. However, both the former and the latter were difficult to fully process. Thus, using the extension analytic hierarchy process to evaluate their contribution, only the main convex hull structure was retained. According to the guidance of T, the spiral curve and the non-smooth structure were replaced by a fractal geometry that was combined with the original model of the valve core. Also, to validate this novel design, its anti-erosion ability was verified by computational fluid dynamics and experiment.

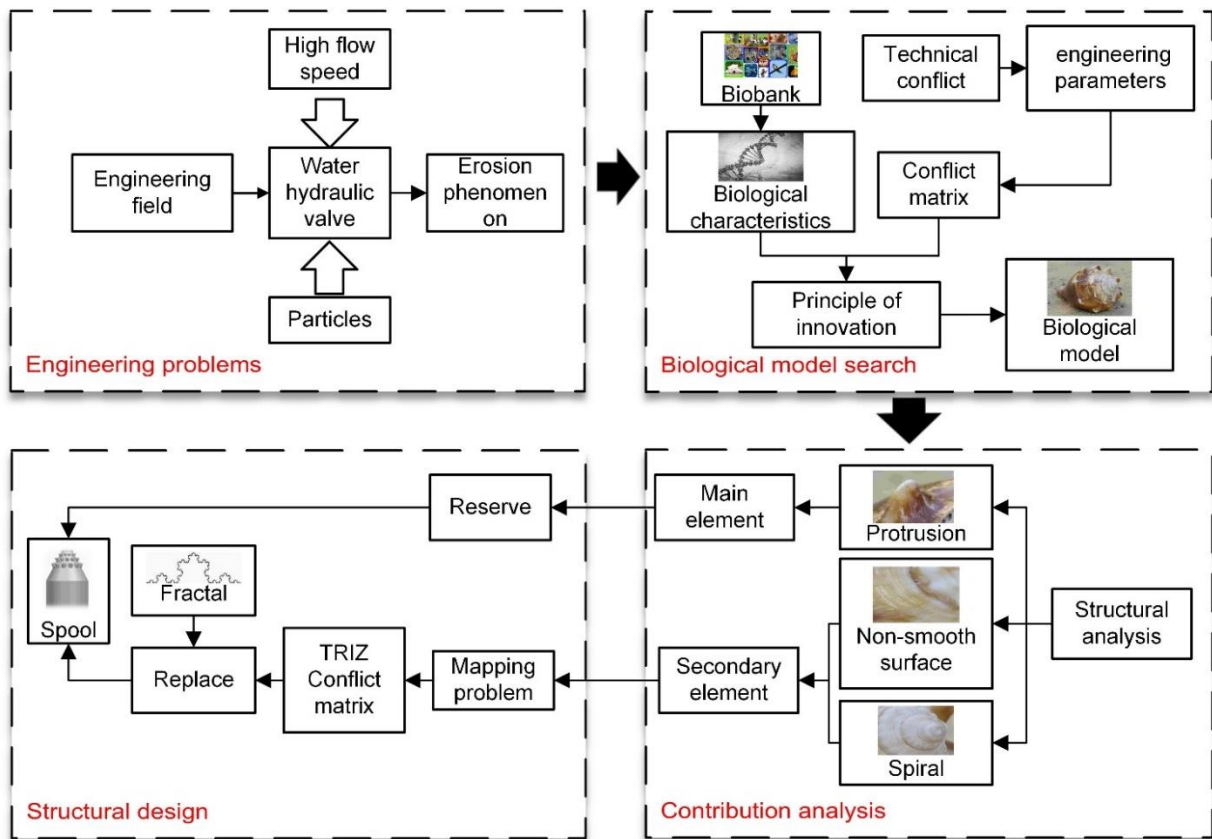


Fig. 1. The brief design process

2 Method

2.1 Bionic combined with TRIZ

The two innovative design methods namely, TRIZ and bionics are widely used in engineering and natural sciences. Bionics has achieved remarkable research results in many fields. However, the following two problems still co-exist.

- (1) The search for biological models is not systematic and it depends on the individual understanding of natural creatures.

(2) The lack of theoretical guidance while transforming biological models into engineering ones, makes it difficult to implement accurate engineering design.

Although some researchers are trying to develop practical approaches that apply biomimicry to technology development, there is still no mature framework for its application [4]. As a popular innovative design method, TRIZ has complete analytical methods and tools starting from initial problem analysis to diverse solutions for different conflicts. Usage of TRIZ can help to make up for the shortcomings of bionics. Their combined effects are as follows:

First, the design goals are analyzed and the actual engineering and technical issues into TRIZ standards are transferred. Secondly, through the TRIZ tool, the principle solution is obtained and through the principle solution and the matching creature is found. Finally, using bionics research methods, the biological structures that meet the design requirements are extracted.

The biological function and TRIZ have a matching relationship. The bionic case can make the abstract principle of TRIZ more visual and suppress the difficulty of transforming from the standard problem of TRIZ to the practice problem of engineering. Applying the principle of TRIZ innovation is also conducive to bionic design.

2.2 Extension analytic hierarchy process

Biological system functions are usually the result of the coupling of multiple factors. Usually, a single bionic design often fails to achieve the target function. For example, the papillary structure of the lotus leaf and the surface waxy material have an effect on the leaf's wettability. So, the "coupling bionics" based on the mechanism and the law of Biological Coupling is proposed [5].

In coupling bionics, the contribution of each coupling element to the bionic function must be clear for targeted research to be carried in order to improve the overall performance. Thus, the extension analytic hierarchy process was applied for the analysis of coupling element contribution and the specific analysis steps are as follows:

- (1) Construct an extension judgment matrix, mainly through comparing and scoring by experts; The coupling elements are compared by experts and given judgment values. The extension interval is used to quantitatively express their relative importance, thus building an extension interval judgment matrix M' .
- (2) Computational comprehensive judgment matrix.

$m_{ij}^t = (m_{ij}^{-t}, m_{ij}^{+t})$ ($i, j = 1, 2 \dots n; t = 1, 2, \dots T$) are the extension interval given by the t^{th} expert. The comprehensive extension interval given by the T experts is

$$m_{ij} = \frac{1}{T} \otimes (m_{ij}^1 + m_{ij}^2 + \dots + m_{ij}^T) \quad (1)$$

Thus, the comprehensive extension judgment matrix M is obtained.

- (3) According to the comprehensive judgment matrix M , the weight vector satisfying the consistency is obtained.

- a) Solve the eigenvector x^- , x^+ corresponding to the M^- , M^+ maximum eigenvalue.
- b) Weight coefficient is calculated by M^- , M^+ ;

$$K = \sqrt{\sum_{j=1}^n \frac{1}{\sum_{i=1}^n m_{ij}^+}}; \quad m = \sqrt{\sum_{j=1}^n \frac{1}{\sum_{i=1}^n m_{ij}^-}} \quad (2)$$

Calculated weight vector $S^b = (S_1^b, S_2^b, \dots, S_n^b)^T = (Kx^-, mx^+)$.

According to the Theorem 2 in the literature [6], the weight vector P of each coupling element to the coupling target is calculated. The vector size represents the contribution of each coupler, indicating the direction of bionics, providing a reference for further bionic design.

2.3 Fractal theory

Fractal geometry [7] is a branch of mathematics developed by the American-French mathematician Benoit B. Mandelbrot used in exploring the complex forms of nature. There are many complex objects in nature, such as coastlines, mountain contours, clouds, stars, just to name a few. It is difficult to describe them using traditional geometric methods. Fractal geometry is a geometry with irregular geometry as the object of study, which can deal with the appearance of non-smooth and irregular shapes, and phenomena in nonlinear systems. The fractals of nature are divided into regular fractals and random fractals. Regular fractals constructed by mathematicians with strictly satisfying self-similarities include the Snowflake Curve and the Sierpinski carpet. A unique property of a fractal object is its measure $M(l)$ and the measured dimension l that obey the following relationship [8].

$$M(l) \sim l^D \quad (3)$$

In the above formula, D is the fractal dimension and $M(l)$ can be the mass, volume, area or length of an object. Another property of fractal objects is their cumulative number and the size distribution of objects obeying the following relationship [9].

$$N(l \geq \lambda) = \left(\frac{\lambda_{max}}{\lambda}\right)^D \quad (4)$$

In the above formula, λ is the diameter of object, N is the number of pore diameters equal to or greater than λ . λ_{max} is the largest diameter of the object, and D is the fractal dimension. Therefore, the total number of features is expressed as follows:

$$N_t = \left(\frac{\lambda_{max}}{\lambda_{min}}\right)^D \quad (5)$$

When a fractal model illustrates an object, it first constructs a random process (or recursive model) and then iterates step by step until the richness of the generated texture details meets the requirements.

3 Design of the valve

3.1 Search of bionic model

Significant changes in the pressure and the flow at the spool of the hydraulic valve is usually observed. Presence of foreign bodies (sand particles) in the fluid impacting the pool results in consequent wear (pits). To reduce wearing of the spool, the water hydraulic valve demands improvement, which might lead to having a more complex structure of the valve inner body. This remains one of the contradictions while solving engineering problems. However, to reduce wear in the engineering field, redesign is mandatory. Hence, this research focuses on reducing the surface stress of the valve core due to particles impacting - by improving its structure. The new problem that arose was the structural complexity leading to a decline in productivity. Thus, the corresponding principle of invention was found in the TRIZ contradiction matrix by using engineering parameters. Table 1 shows the TRIZ particular solutions given by the TRIZ contradiction matrix.

Table 1: Fragments of Contradiction matrix

Engineering parameters	Productivity
Stress or pressure	10,14,35,37

Through comparative analysis, the innovative principle 14 was selected as the reference scheme for the valve core design. The corresponding biological cases of innovation principle 14 are shown in Table 2.

Table 2: Biological examples after TRIZ analysis

Number	Inventive principle	Biological examples
14	Spheroidality-Curvature	The dung beetle has convex hull and pits on the surface to reduce resistance. The non-smooth shell of a shellfish.

Its innovative principle is explained as follows:

Number 14: Spheroidality-Curvature

- (1) Replace a line or plane with a curve or a surface.
- (2) Use a ball or spiral structure.
- (3) Replace linear motion with rotary motion.

The body surface of a dung beetle having a convex hull is taken as the first case. Likewise, the non-smooth surface and spiral structure of the shell conforms to the first case and second case, respectively.

Based on the structural characteristics of the valve core, a conical conch was taken as a biomimetic model. According to the relevant information, the conch is mainly produced in shallow seabeds of the coastal areas. Considering the structural characteristics of the valve core, the conical conch was taken as a biomimetic model. It can be seen from the rocks washed by the sea and the mouth of the river, the harsh environment of the conch is exposed to. As a shield, it has created its erosion-resistant casing. As shown in Fig. 2., the conch has a fusiform shape, its middle shoulder is raised, and the outer shell exhibits a non-smooth surface structure. A spiral

is emitted from the tail and extends all the way to the shoulder and there are prominent protrusions on the spiral line. It can be concluded that these protrusions, spirals, and non-smooth surfaces can reduce the erosion of sediments. The outer shell of the conch is well protected against abrasion and erosion. It can also be observed that even though the bulge on the back of the conch is severely worn, the key head is well protected.

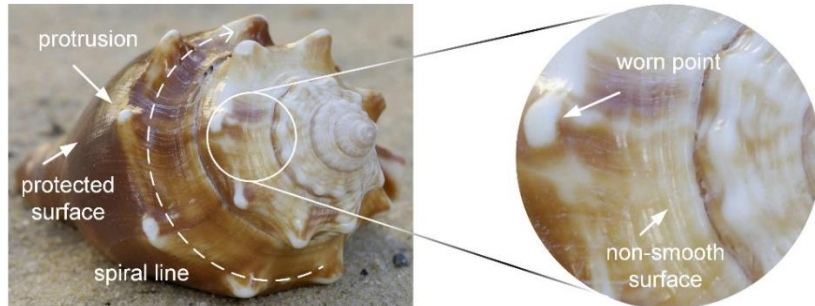


Fig. 2. Surface structure of conch

3.2 Coupling contribution analysis

The coupling stratification analysis was used to analyze the coupling contribution of the multiple coupling elements of the conch with erosion resistance. The coupling elements are the protrusion, the non-smooth surface shape, and the radioactive spiral. The experts scoring the protrusions, the non-smooth surface, and the radioactive spiral coupling elements, obtained the extension interval number judgment matrix M' of the relative contribution of the coupling elements. According to the extension interval number judgment matrix M' , the comprehensive judgment matrix M is obtained as follows.

$$M = \begin{bmatrix} (1.00,1.00) & (2.78,3.22) & (3.80,4.70) \\ (0.31,0.36) & (1.00,1.00) & (1.58,2.18) \\ (0.21,0.27) & (0.47,0.66) & (1.00,1.00) \end{bmatrix};$$

$$M^- = \begin{bmatrix} 1.00 & 2.77 & 3.84 \\ 0.31 & 1.00 & 1.58 \\ 0.21 & 0.48 & 1.00 \end{bmatrix} \quad M^+ = \begin{bmatrix} 1.00 & 3.23 & 4.71 \\ 0.36 & 1.00 & 2.14 \\ 0.27 & 0.65 & 1.00 \end{bmatrix};$$

Calculated:

$$x^- = (0.63 \quad 0.23 \quad 0.13)^T \quad x^+ = (0.63 \quad 0.23 \quad 0.14)^T; k=0.9, m= 1.02.$$

Thereby getting:

$$S_1^b = (0.62 \quad 0.64), S_2^b = (0.22 \quad 0.24), S_3^b = (0.13 \quad 0.14);$$

$$P_1^b = V(S_1 \geq S_3) = 48.37, P_2^b = V(S_2 \geq S_3) = 12.65, p_3^b = 1.$$

Through normalization, the weight vector of each coupling element's impact on the functional target is $p=(0.779 \quad 0.204 \quad 0.016)^T$. Therefore, the protrusion is the main coupling element, the non-smooth surface is the secondary main coupling element, and the spiral curve is the general coupling element.

Through the above method, we found a biological model, the Conch, to solve engineering problems. However, the surface of the conch is irregular and the spiral curve is difficult to map to the spool. If the imitation is forced to achieve the design effect, it will inevitably increase the manufacturing difficulty. In order to solve this design contradiction, the contradiction matrix method of TRIZ is used. Optimization is done to reduce the surface stress generated by the

valve core upon the impact of the particles. However, the manufacturability is low. Table 3 is a TRIZ special solution derived from the TRIZ contradiction matrix.

Table 3: Fragments of Contradiction matrix

Engineering parameters	manufacturability
Stress or pressure	1,16,35

The shape of the secondary main coupling element can be obtained from principle 16 “Not reaching or overacting” and principle 35 “Parameters change”.

According to fractal theory, non-smooth surfaces of the conch can be characterized by random fractals. But random fractals are too complicated. It cannot use math to express or build a model. According to the TRIZ special solution "not reaching or overacting and parameters change", simplified regular fractals can replace complex random fractals. So, the spiral has been replaced by a certain angle of rotation. The general structure is as shown:

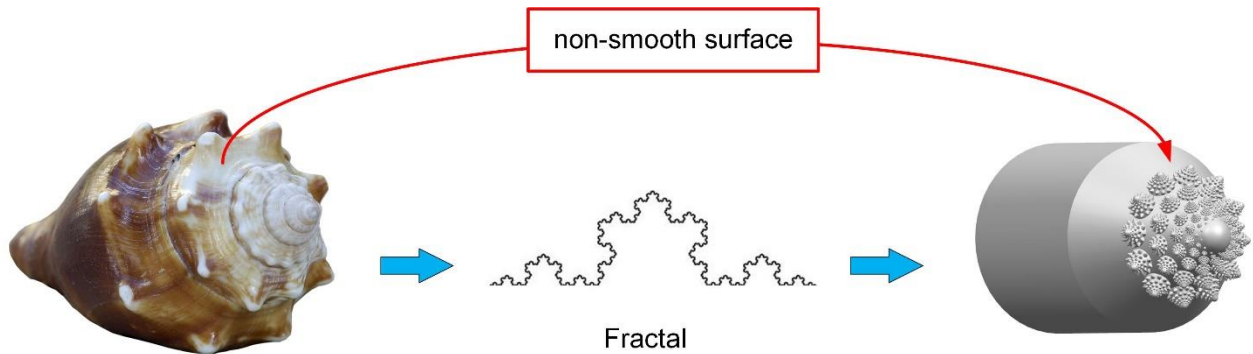


Fig. 3. Mapping of non-smooth surface

The specific structural parameters of the fractal was designed according to the formula of the fourth part. There is a certain functional relationship within the regular fractal, which limited the freedom of design and lead to contradictions. There was no interference between the features. When the valve was working, the valve core had to match with the valve seat, so the maximum diameter of the valve core remained smaller than the minimum inner diameter of the valve seat. Due to manufacturing accuracy, the minimum feature was greater than the machining accuracy. The diameter of the bottom surface of the valve core was 12.5mm, and the minimum inner diameter of the valve seat was 16mm. Also, the 3D printing technology using photosensitive resin had a processing precision of 0.02mm. Through the calculation and analysis and CAD mapping measurement, a set of optimization parameters for solving contradictory problems was obtained.

$$M_A = \begin{bmatrix} O'_A & c_1 & \text{conical} \\ & c_2 & 0.2 \\ & c_3 & 0.2 \\ & c_4 & 4 \\ & c_5 & 12 \\ & c_6 & 3 \end{bmatrix}, M_B = \begin{bmatrix} O'_B & \text{Relative angle between layers} & 15^\circ \end{bmatrix}$$

M_A is a fractal parameter that replaces a non-smooth surface, c_1 represents the overall shape of the spool (first dimension); c_2 indicates that the difference in the multiple of the different layers relative to the first layer in the same dimension; c_3 indicates that the feature size of a layer in the same dimension is a multiple of the previous layer; c_4 represents the number of layers in a dimension; c_5 represents the number of uniform distribution of a layer of protrusions around the valve core axis; c_6 represents the total dimension of the fractal. M_B is the relative rotation angle between the layers instead of the spiral. According to the above parameters, the diameter of the bottom surface of each convex hull is shown in Table 4. The spool model is shown in Fig 4.

Table 4: The diameter of convex hull

Bottom diameter(mm)	First layer	Second layer	Third layer	Fourth layer
First dimension	12.5	---	---	---
Second dimension	2.5	2.0	1.5	1.0
Third dimension	0.5, 0.4, 0.3

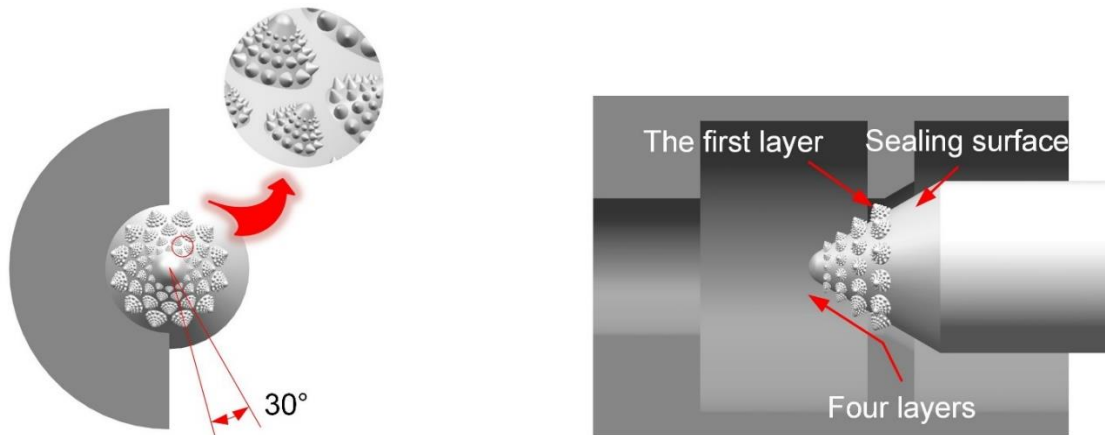


Fig. 4. Spool structure and assembly

4 Numerical approach

The 3-D geometries generated in NX 10.0 were imported to ANSYS Workbench 17.0. Then, the meshing module was used to discretize the model. Next, Fluent was used to simulate the models with all the calculated boundary conditions. Fig 5 shows the sliced solid and fluid discretized domains of the valve. Both models were given an inlet pressure of 1 MPa and an outlet pressure of 0.1 MPa. To simulate the viscosity and the turbulence of the fluid flow, the standard k-ε model and the discrete phase model were used. The calculation results are illustrated in Fig 6 and Fig 7.

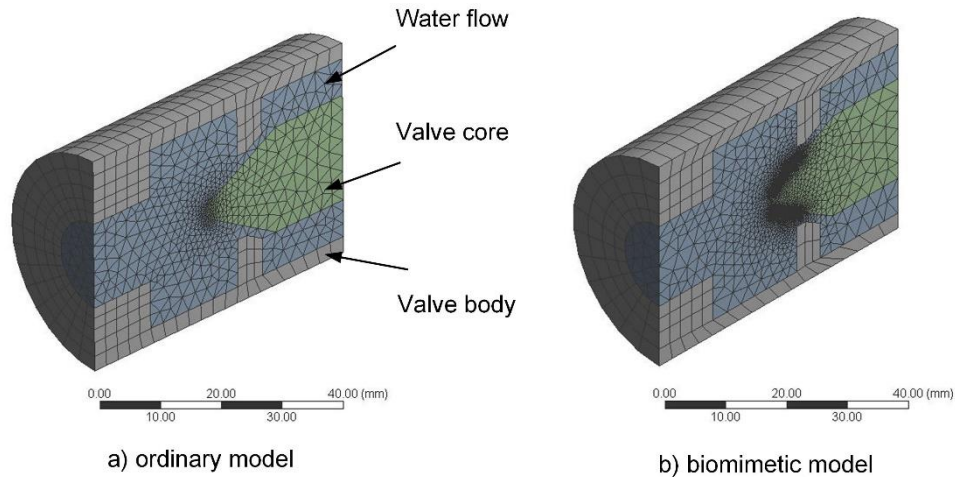


Fig. 5. Meshing

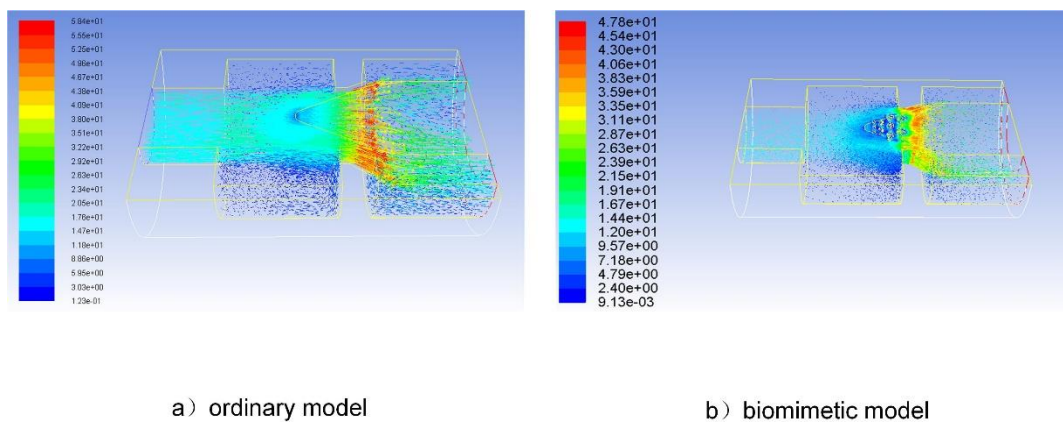


Fig. 6. Water flow velocity

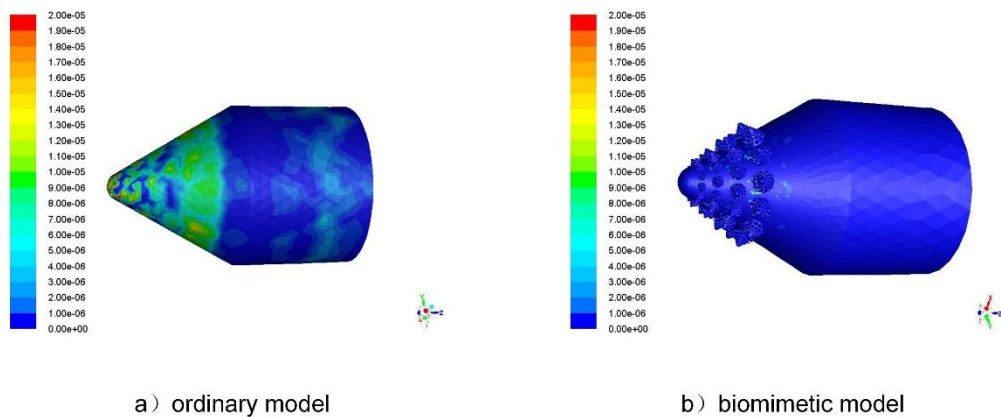


Fig. 7. Erosion rate

Fig. 7. shows the erosion rate is lesser in the bionic model as compared to the ordinary model, which is also validated by observing Fig. 6. When the water passes through the protrusion of the valve core, vortices are created next to it. These vortices slow the flow of water and change the direction of impact of the particles. Under the impact of the particles, the bumps first wear out, but the important sealing surface remains protected.

5 Experiment setups

5.1 Comprehensive test bench

To test the erosion resistance of the new valve core, a water hydraulic test bench was set up, classified into a water hydraulic power transmission subsystem, an electric control subsystem, and an experimental signal acquisition subsystem, respectively. The electric control subsystem was used to control water hydraulic power transmission subsystem to set the initial parameters of the experiment. Also, results form the experimental signal acquisition subsystem were analyzed. The experimental schematic and experimental setup are shown in Fig 8.

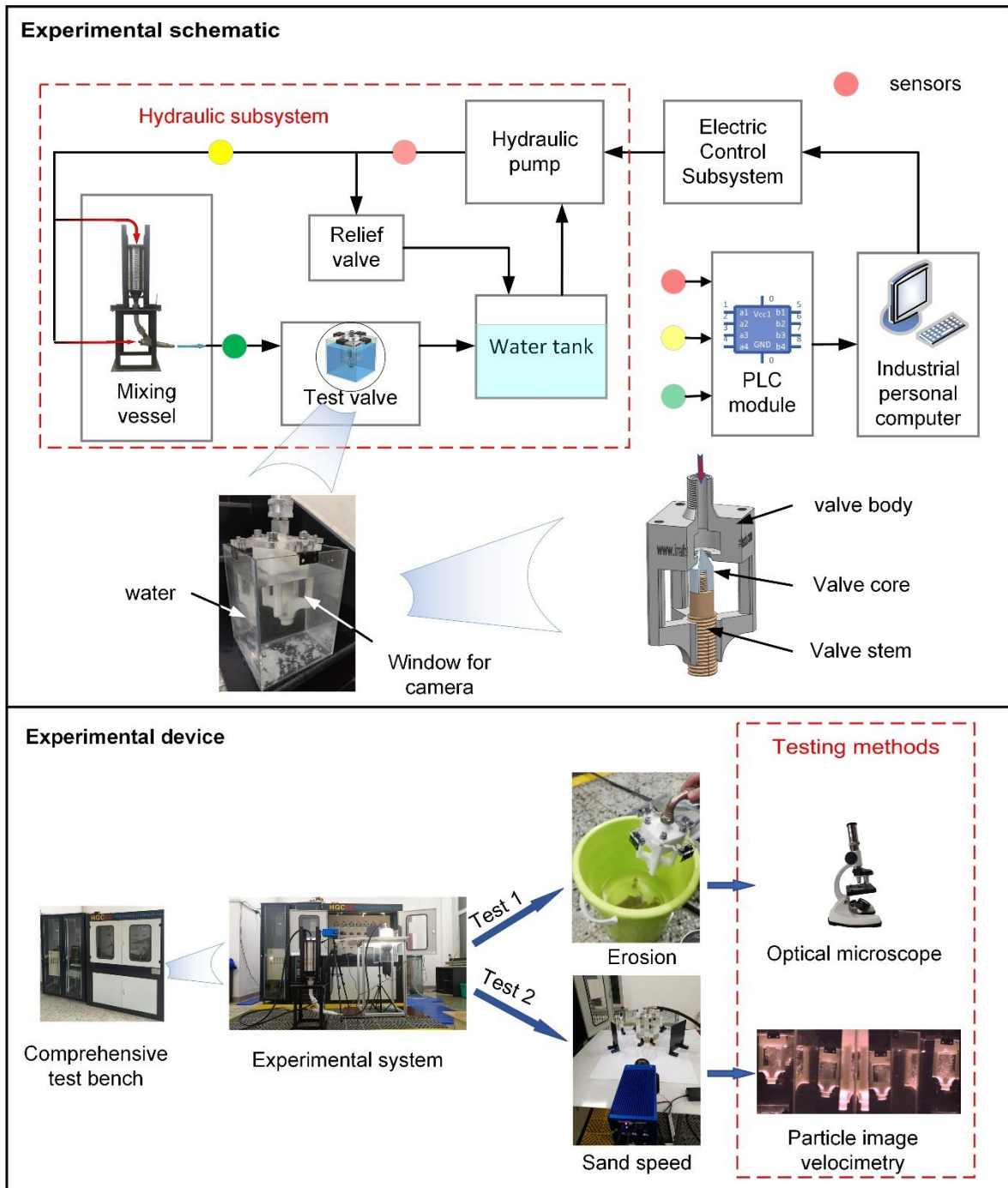


Fig. 8. Overall structure of water hydraulic test bench

From Fig. 8., solid particles in the fluid are added through the mixer. Since the upward and downward pressure are uniform, the sand particles are mixed into the fluid under the action of gravity. In order to observe the fluid flowing through the valve, the valve body required usage of highly transparent plexiglass. However, under erosion due to sand particles, the transparency of the plexiglass valve body was easily destroyed, limiting the ability of the expensive valve's body to be recycled. Hence, a semi-hollow valve body was proposed to solve this problem. Putting the valve body in the water tank not only helped in carrying out the anti-erosion experiment, but also allowed observing the speed of the erosion particles past the valve core.

5.2 Result

Optical microscope (Test 1) was used to observe the erosion of the sealing surface of the valve core. As shown in Fig. 9., with the microscope magnification of 100, the ordinary spool had a higher roughness than the biomimetic spool, which is consistent with the simulation results.

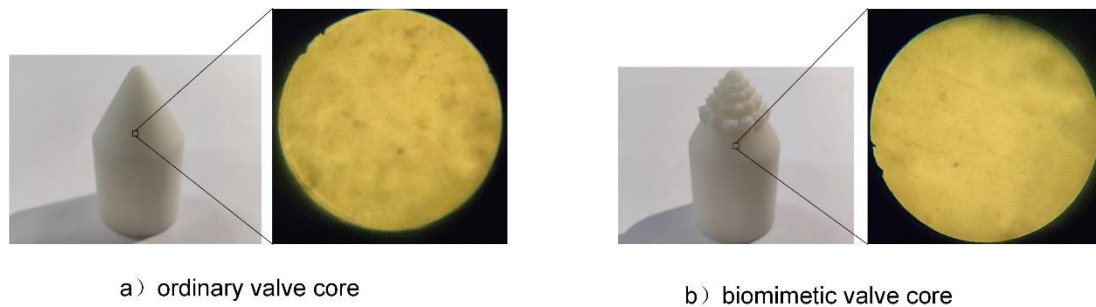


Fig. 10. Result of erosion

6 Conclusions

TRIZ, Bionics, and Fractal were used to design a novel valve core structure for an enhanced erosion resistance of the valve. Biological models were found through TRIZ and Bionics and the main factors defining the function of the biological models were identified by an extension analytic hierarchy process. The detailed parameters of the valve core structure were determined by TRIZ and Fractal and through simulation. It was shown that the non-smooth surface with a convex hull helped resist erosion. The combination of the three methods greatly improved the design efficiency and this investigation provided a new inspiration and novel thinking to bionic design in peer research. In the future, captured images with a high speed camera (Test 2), requiring image processing to calculate the speed of the sand will be done.

Acknowledgements

This work was supported by the Natural Science Foundation of China under Grant 51875113, Natural Science Foundation of the Heilongjiang Province of China under Grant F2016003, Natural Science Joint Guidance Foundation of the Heilongjiang Province of China under Grant LH2019E027, "Jinshan Talent" Zhenjiang Manufacture 2025 Leading Talent Project, "Jiangyan Planning" Project in Yangzhong City. This paper is funded by the International Exchange Program of Harbin Engineering University for Innovation-oriented Talents Cultivation.

References

1. Maurer C., Schulz U. J. W. "Solid particle erosion of thick PVD coatings on CFRP". vol. 317, no. 1-2, pp. 246-253, 2014.

2. Feng C., Jiang S., Liang J. J. A. S. S., “Cavitation erosion resistance of microarc oxidation coating on aluminium alloy”. vol. 280, no. 8, pp. 287-296, 2013.
3. Koch K., Bhushan B., and Barthlott W. “Multifunctional surface structures of plants: An inspiration for biomimetic”. (in English), Progress in Materials Science, Review vol. 54, no. 2, pp. 137-178, Feb 2009.
4. Lim C., Yun D., Park I., and Yoon B., “A systematic approach for new technology development by using a biomimicry-based TRIZ contradiction matrix”. Creativity and Innovation Management, vol. 27, no. 4, pp. 414-430, Dec 2018.
5. Ren L. Q. and Liang Y. H., “Biological couplings: Classification and characteristic rules”. (in English), Science in China Series E-Technological Sciences, Article vol. 52, no. 10, pp. 2791-2800, Oct 2009.
6. Gao J., Sheng Z.H. “A study on the Extension AHP Method”. Nanjing, China. Systems Engineering. Vol.20, No.5,2002.
7. Mandelbrot B. B. “The Fractal Geometry of Nature”. San Francisco, Freeman, 1982.
8. Yu B. M., Li J. H., “Some fractal characters of porous media”. (in English), Fractals-Complex Geometry Patterns and Scaling in Nature and Society, Article vol. 9, no. 3, pp. 365-372, Sep 2001.
9. Yu B. M., Lee L. J., “A fractal in-plane permeability model for fabrics”. (in English), Polymer Composites, Article vol. 23, no. 2, pp. 201-221, Apr 2002.

Communication

Communicating Author: railway_dragon@sohu.com

TRIZfest 2019
September 11-14, 2019. Heilbronn, Germany

INTERVIEW LESSON

Evgenia Guin, Anatoly Guin

Association «Education for a New Era», Moscow, 105000, Russia

Paper Classification:

- Educational methods and experiences

Abstract

In this article we describe interview lesson. The main idea of interview lesson is that the teacher explains new material by answering students' questions. We describe interview lesson plan and the results of using this method in the educational process.

Keywords: *TRIZ-pedagogy, question, motivation, education.*

1 Interview lesson

Teaching method "Press conference" is described in the book "Methods of Educational Techniques" by Anatoly Guin [1].

The method's formula: the teacher deliberately addresses a topic incompletely, inviting students to ask questions that reveal the topic.

This technique was first published in 1998, since then a lot of experience has been gained and the technique has evolved.

In this article, we describe interview lesson, which is based on the "Press Conference" method. The main idea of interview lesson is that the teacher explains new material by answering students' questions.

The following are some advantages of the proposed lesson form:

- No one likes to hear answers to unasked questions. But this is exactly how the traditional school is organized - children receive answers to questions that they are not interested in. Interview lesson allows you to flip this process: during this lesson students receive answers to their own questions, which significantly increases their involvement in activities, their motivation.

- Children learn to ask questions correctly and classify them.
- The ability to make a system of questions that reveal a topic and form an understanding is developed. Few people have these skills but they are very important in life.
- Students formulate their own thoughts, speak freely, and do not repeat other people's thoughts.
- To ask a deep question, you need to think. Therefore, such lessons develop thinking abilities.
- Children learn to listen and hear each other in order to get a leverage from each other's questions.
- If a student knows how to answer a question then he or she is allowed to do so. Thus, knowledgeable students get opportunity to find personal fulfillment through their knowledge.

2 Types of questions

For a successful interview lesson, it is desirable to familiarize students with the types of questions in advance (see Fig. 1):

- Repeating questions. Answers to such questions are already contained in the information provided.
- Clarifying questions. There are no answers to such questions in the information provided, but finding them is not very difficult. As a rule, this is reference information readily available. Loosely speaking, we can say that these are questions the answers to which are easy to find on Google.
- Open questions. There is no single true answer to such questions. Such questions can be controversial, may require reasoning to find an answer, comparison of sources, analysis of information, research. Google will not answer these questions.

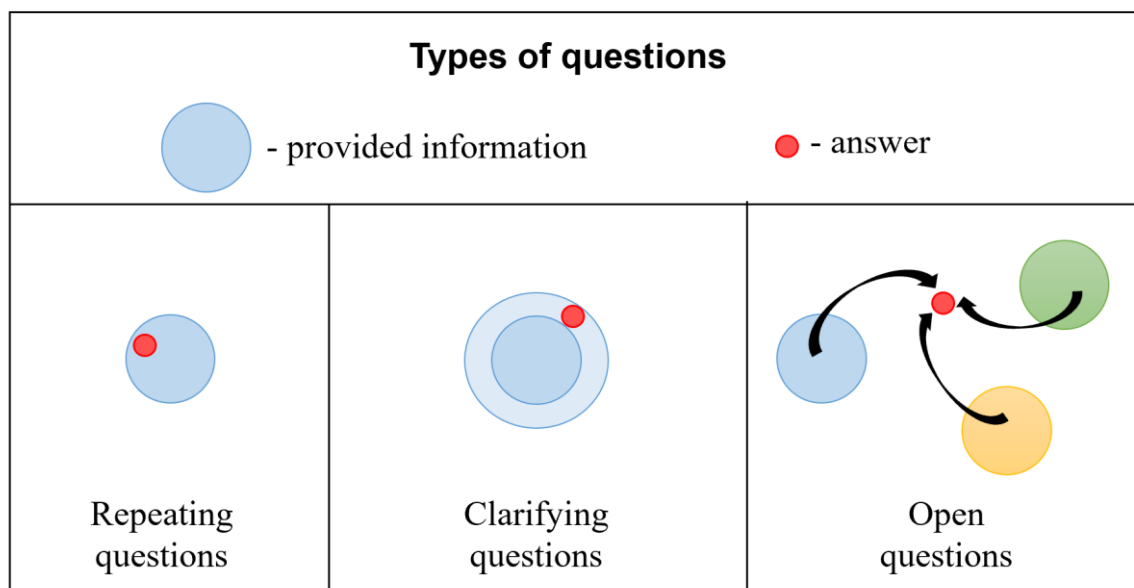


Fig. 1. Types of questions

3 Interview lesson plan

Interview lesson consists of the following stages:

- **Introduction.** The purpose of this stage is to intrigue students with the topic of the lesson, to set them up for active, creative activity. An introduction may be an amazing fact, mystery, open problem, yes-no riddle, vivid experiment, doodle, funny test or a specially designed game.
- **Incomplete explanation of the topic.** At this stage, the teacher gives a brief reference on a new topic. It is important to select information for reference in such a way that, starting from it, students can compose a system of questions that covers all the material planned for the lesson. The information can be provided in different forms: oral, short video, text to read, photograph, diagram, etc. Different students may receive different information at this step.
- **Preparing questions.** At this stage, the teacher gives students a task to make questions about the information from the previous paragraph. The teacher can specify quantitative requirements, for example, make 3 repetitive, 5 clarifying, 1 open question. Various different formats of work are possible: in mini-groups (3-4 people), in pairs, individually.
The use of role-playing significantly animates this stage. For example, in a lesson dedicated to studying the Victorian era in the UK, the teacher can make children act as journalists. Some of the students will represent pro-government press, some - the opposition, and the rest - the yellow press. Children like this format very much, and the results of mastering the material get better.
- **Common list of questions.** All student questions are combined into a common list. In the case when some questions which are important for covering the topic are not asked, they are added by the teacher. Further, the teacher comments on the resulting list, identifies questions that will be answered in the lesson, questions that are answered in the literature, but will not be answered in the lesson, and questions that cannot be answered by anybody in the world today.
- **Explanation of the new material.** The teacher explains the topic of the lesson by answering questions from the list. If one of the students knows the answer to any of the questions, the teacher allows him to speak up. If at the second stage the students studied different material, now they can answer the questions of classmates and teach each other.
- **Completion.** The goal of this stage is to gain new questions, show boundaries of students' knowledge, motivate students to wait for the next lesson, and provide food for thought for the time between lessons. At this point it is also helpful to reflect on the lesson.

The basic lesson plan is described here. Of course, when developing a specific lesson, the teacher can make changes. And changes are even desirable so that the lessons are not all alike. The main thing is to build a lesson through the answers to students' questions, and in the rest many variations are possible.

For example, you can arrange the game "students versus teacher": students try to ask a question that will confound the teacher or require an answer lasting more than three minutes.

4 Experience gained

By now interview lessons have been conducted by many teachers in different cities and countries. The age of students has been very different: from preschoolers to students.

A lesson conducted by the scenario proposed can be developed either for an out-of-school topic or for studying almost any paragraph from a textbook.

The interview lesson goes well with “flipped class” technique.

An additional advantage of the proposed technique is that it is relatively easy for a teacher to prepare a new lesson in this scenario.

As a result:

- Students are actively involved in the process.
- They interact with each other, learn to work in a team.
- Self-acquired knowledge is valued higher by students.
- Students understand that the more you know, the more questions you have. In the process of preparing questions, they, among other things, repeat the material that was previously covered.

References

1. Guin A. «Приемы педагогической техники. Свобода выбора. Открытость. Деятельность. Обратная связь. Идеальность». 16-е издание (2019). Вита-Пресс, Россия
2. Guin A., Guin E. «Урок-интервью» Article. <https://trizway.com/art/pedtelnika/press-konferenciya-na-primere-uroka-biologii.html>

Communication

Communicating Author: evgenia.guin@gmail.com

TRIZfest 2019

September 11-14, 2019. Heilbronn, Germany

LOGICAL NEGATION IN CECA MODEL

Jerzy Chrzęszcz^{a,b}

^a *Institute of Computer Science, Warsaw University of Technology, Warsaw, 00-665, Poland*

^b *Pentacomp Systemy Informatyczne S.A., Warsaw, 02-222, Poland*

Paper Classification:

- Theoretical, research results

Abstract

The concept of negation is as fundamental to logic as the concept of zero is fundamental to other disciplines of mathematics and therefore it constitutes an important paradigm of reasoning and proving. Within TRIZ, negation is applied in different forms, starting from the inventive principles and all the way to definitions used in ARIZ and other tools. Sometimes it appears in its strict logical meaning and sometimes it is used as a generic term. This paper provides a brief overview of these applications, with particular focus on the Cause-Effect Chains Analysis (CECA) and discusses the differences between negation and contradiction, being one of the basic TRIZ notions.

It was demonstrated during the recent TRIZ conferences, that a CECA diagram may be converted into a logical model and enriched with quantitative extensions. In this paper we analyse the applicability of the logical negation and complementary conditions in qualitative and quantitative CECA models and propose some guidelines for using them.

Keywords: *TRIZ, CECA, logical model, quantitative model, negation, complementary conditions.*

1 Negation in TRIZ

The concept of negation (or inversion) is used within several TRIZ areas in many different ways. This section provides an overview of these applications, as a background for the rest of the paper.

1.1 Inventive principles

Probably the most well-known references to negation in TRIZ are the inventive principles. Firstly, the obvious choice is *Inversion* (alias *The Other Way Around*), suggesting the use of an opposite approach, action or orientation. Secondly, there are two principles with opposition explicitly indicated in their names: *Anti-Weight* and *Preliminary Anti-Action*. Finally, negation is also implied by the name of *Blessing in Disguise* principle (alias *Harm Into Benefit*), which suggests converting unwanted effects into something beneficial for the system.

1.2 Literature search

Quick research performed on selected conference proceedings (TRIZfest, TRIZ Future) and selected online repositories (matriz.org, triz-journal.com, metodolog.ru) indicated that the word *negation* does not appear neither in the TRIZ Body of Knowledge [1] nor in the official TRIZ Glossary [2], while the word *negative* is used as *undesired* or *harmful* in such phrases as *negative effect*, *negative impact* and *negative function*. In the other sources the word *negation* appears mainly in phrases *negation of negation*, *double negation* and *rule of negation*, describing underlying philosophical concepts or generic design approach of TRIZ.

A reference to logical negation in its strict sense appears in the training materials [3] approved by MATRIZ, as the concept of *Hamlet contradictions* (i.e. *if X exists / if X does not exist*), used in step 1.1 of ARIZ. Negation in a wider sense is also referred to in the Function Modelling area by the guideline stating that *no negative formulations* should be used for describing a function (as the list of functions that a component *does not perform* is basically endless). Negative and positive approach to formulation of problems is discussed in [4].

1.3 Logical negation vs. contradiction

The concept of *contradiction*, being one of the fundamental TRIZ notions, is built upon *conflict* of requirements, but it is more specific. Likewise, *negation* is more specific than contradiction. It was demonstrated in [5], that conflicting requirements identified during cause-effect analysis facilitate formulation of the contradictions. However, describing disadvantages in a qualitative way may be misleading, e.g. rotation speed of a propeller being “insufficient” in the context of the required lift force may be at the same time “excessive” in the context of allowable noise level. This example shows that a legitimate contradiction of requirements (insufficient vs. excessive rotation speed) is inadequate to recognize conditions as complementary [10].

Indeed, the condition *two logical variables must always evaluate to opposite values* is necessary, but not sufficient. Actually, the requirement of unequal values of two or more logical variables defines Exclusive OR (XOR) function, differing from the regular OR by excluding the case of all inputs being active simultaneously, i.e. 2-input XOR gate outputs 1 only for 01 or 10 on its inputs. So in addition to being *mutually exclusive* (not to overlap), complementary conditions must also be *collectively exhaustive*, i.e. they must combine together to encompass the whole space of possible values [10].

On the other hand, the usual way of describing disadvantages does not respect this rule, as it is driven by the traditional TRIZ perspective of conflicting requirements. Such approach results in descriptions, which are useful for identifying contradictions, yet insufficiently precise for determining complementary conditions. This situation may be remedied by using quantitative descriptions of conditions, which refer to values of specific parameters of the objects involved in the development of the disadvantages [5, 7]. Unfortunately, practical application of this approach is subject to several limitations, as it is described in section 3.

2 CECA and logical models

2.1 CECA basics

Cause-Effect Chains Analysis (CECA) is used for investigating causality relations in the analysed system [8, 9]. Starting with the known *target disadvantages* selected for removal, the subsequent *intermediate disadvantages* are investigated one after another, forming linear chains of causes. The analysis of a given chain stops upon finding a *root cause* considered to remain beyond control, such as a law of physics or a specific project constraint. Because of their nature

the root causes are unlikely to be eliminated and therefore CECA procedure aims at indicating the *key disadvantages*, removal of which is expected to eliminate the target disadvantages.

The linear chains may connect at inputs with *common causes* or at outputs with *logical operators*, indicating how the input causes contribute to the output effect. An AND operator is used if all inputs must be jointly active to trigger the effect and an OR operator is used if activity of any of the inputs is sufficient to trigger the effect. The CECA procedure is documented with a diagram depicting a directed graph comprising nodes of two types (the boxes describing disadvantages and the logical operators) and edges (arrows) indicating the flow of causality.

Among a few examples found in the TRIZ literature where *negation* is used as a logical operator, probably the most known within the cause-effect analysis area are [10] and [11]. References to negation applied during conversion of groups of *key disadvantages* into groups of the *key problems* to be solved are given in [12] and [13]. Negation also appears implicitly in the definition of the *target disadvantage*, being *the inverted goal of the project* [3].

2.2 Combinational logical model

The original concept of transforming a CECA diagram into a logical model was presented in [10]. It relies on decomposing the model into a context-dependent layer (contents of the boxes describing particular disadvantages) and a context-independent layer (structure of connections between the boxes, including AND / OR operators). Causes are represented as logical 1s (when active) or 0s (when inactive). The logical model of the structure may be formally represented as a set of combinational switching functions and then analysed and minimized using methods of Boolean algebra. Such approach enables evaluation of the properties of the model, e.g. the influence of a given cause on the target disadvantages or assisting in selection of the key disadvantages.

Significant enhancements to this concept introduced in [14] included unified modelling of linear chains and simple loops as well as modelling of removal of an intermediate disadvantage without removing its predecessors. It was also demonstrated, that propagation of causality within a linear chain of disadvantages is similar to dealing with external risk factors (hazards) and internal vulnerabilities (weaknesses) of the components involved in the development of the disadvantage. Further exploration of the vulnerability-oriented perspective was proposed in [12], with some recommendations for structuring CECA models.

2.3 Quantitative extensions to combinational model

On top of the logical improvements, some quantitative extensions of the CECA model were also proposed in [14], including a generic procedure supporting selection of the most impactful disadvantages and the most promising solution directions using risk management perspective. Some measurement scales were presented, together with sample parameters allowing considered variants to be ranked accordingly to their quantitative characteristics – estimated impact of the candidate key disadvantages on the target disadvantages and estimated profitability of the candidate solutions. The proposed procedure explores similarities between the risk factors and the disadvantages as well as between the risk mitigation options and the candidate solutions:

Risk management

1. identify risk factors,
2. estimate initial risk magnitude,
3. select major risks from prioritized results,
4. analyse risk mitigation options,
5. estimate residual risk magnitude,
6. estimate risk mitigation costs,
7. calculate profitability of mitigation options,
8. select mitigation options.

Quantitative CECA

1. identify disadvantages,
2. estimate initial impact of disadvantages,
3. select key disadvantages from prioritized results,
4. analyse solution options,
5. estimate residual impact of disadvantages,
6. estimate disadvantage removal costs,
7. calculate profitability of solution options,
8. select solution options.

2.4 Sequential logical model

Another approach using methods coming from computer science is modelling of a CECA diagram as a state machine or automaton, described in [16, 17]. The CECA diagram is perceived as a system of interconnected *harmful processes*, which jointly “produce” target disadvantages. Proposed conversion uses *condition-action* perspective devised in [7]. The disadvantages described in the CECA diagram as interactions between the objects are converted into *states* of the state machine model and the disadvantages described as conditions are converted into conditional *transitions* between states. An OR operator in the CECA diagram is transformed into a group of edges in the state machine diagram (one edge for each input), modelling the alternative of conditions required for transitions to the respective output state. An AND operator in the CECA diagram is transformed into additional “wait” node and appropriate edges in the state machine diagram, to model transitions to the respective output state upon the required coincidence of conditions.

The state machine model provides a direct, precise and legible representation of causality perceived as a sequence of actions orchestrated by specific conditions. Each of the CECA linear chains is converted into a separate state machine, operating in parallel with the others and synchronizing with them upon common conditions. Such model seems to reflect time-related aspects of causality better than regular CECA diagram and it offers a more unified and more disciplined representation [16]:

- stages of the process and transitions between stages are clearly distinguished, which makes the model more comprehensible,
- logical operators are converted into states and / or transitions and disappear as a separate type of nodes, which makes the model simpler,
- both nodes (states) and edges (arrows) are labelled, which makes the model more compact.

3 Negation in CECA models

The outputs of logical operators mentioned so far depend on multiple inputs: AND operator outputs 1 if and only if all its inputs are 1s and it outputs 0 otherwise, while OR operator outputs 0 if and only if all its inputs are 0s and it outputs 1 otherwise. Logical negation is a unary NOT operator that outputs inverted state of its single input, i.e. the output is 0 for 1 on input and it is 1 for 0 on input.

3.1 Logical negation and minimization

It was shown in [10] that availability of same variable in position (directly) and negation (inverted) significantly increases chances for substantial minimization of the combinational functions in the logical CECA model. Indeed, in such a case if the input is true (active), then its inverted value must be false (inactive) – and vice versa. Simply put, only one of the complementary inputs may be an active cause at any given moment, which simplifies the minimization process. The rules of logical minimization are formally described below in an infix notation – plus sign denotes OR operator, concatenation of symbols denotes AND operator and apostrophe indicates negation.

$$\begin{array}{cccccc}
 a + 0 = a & a + 1 = 1 & a + a = a & a + a' = 1 & (a + b)' = a'b' \\
 a0 = 0 & a1 = a & aa = a & aa' = 0 & (ab)' = a' + b'
 \end{array}$$

As an example, let us consider a disadvantage that becomes active when at least 2 of 3 contributing causes are active, as shown in Fig. 1 (this is a special case of an m-of-n gate used in Fault Tree Analysis to model redundant configurations of engines, power supplies etc.).

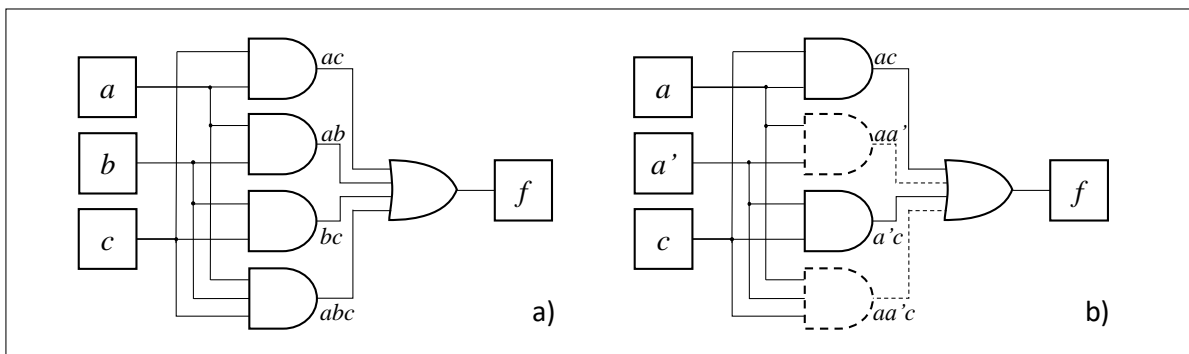


Fig. 1. Sample CECA model (a), and the same model with $b = a'$ (b)

The original function may be described as:

$$f = ab + ac + bc + abc,$$

and after minimization:

$$f = ab + ac + bc(1 + a) = ab + ac + bc.$$

Indeed, the 3-argument combination abc is covered by any of the 2-argument combinations.

If it so happens that $b = a'$, the function becomes: $f = aa' + ac + a'c + aa'c = aa' + c(a + a' + aa')$

Since $aa' = 0$ and $a + a' = 1$, we obtain:

$$f = 0 + c(1 + 0) = c.$$

In digital design area the cost of implementation of a combinational function mainly depends on the number of the logical gates used. Therefore, if the original expression of the function is too complex, it might be beneficial to implement the negated logical function and invert its output. Let us analyse truth table and analytical description of a 2-of-4 gate and its inverted form shown below. As can be seen, direct representation requires 7 gates, while the complementary function only needs 5 gates.

	ab	cd		
	00	01	11	10
00	0	0	1	0
01	0	1	1	1
11	1	1	1	1
10	0	1	1	1

	ab	cd		
	00	01	11	10
00	0	0	1	0
01	0	1	1	1
11	1	1	1	1
10	0	1	1	1

$$f_1 = ab + ac + ad + bc + bd + cd$$

6 × AND + OR

$$f_0 = a'b'c' + a'b'd' + a'c'd' + b'c'd'$$

4 × AND + OR

Apart from minimizing direct or inverted form of a function, another concept heavily used in this area is *don't care* value. Sometimes a logical function to be implemented is not fully defined, i.e. the output is allowed to be either active or inactive for some specific combinations of arguments (especially, if these combinations do not appear on inputs during circuit operation). Such functions are described not only with 1s and 0s, but also with don't cares (Xs) and they may minimize much better than fully defined functions, achieving a smaller (cheaper) implementation, as shown below. This is because every X instance may be regarded either as 1 or 0, whichever is more convenient. Although the don't care value does not seem to have a direct counterpart in the CECA domain, the potential benefit of obtaining much simpler solutions is worth exploring.

	ab	cd		
	00	01	11	10
00	0	1	1	0
01	0	1	1	0
11	0	1	0	0
10	0	0	1	0

	ab	cd		
	00	01	11	10
00	0	1	1	0
01	0	1	1	0
11	0	1	x	x
10	x	x	1	0

$$f_1 = a'd + bc'd + b'cd$$

$$f_x = d$$

3.2 Logical negation and vulnerabilities

Logical negation is used in vulnerability-based approach to generate solution ideas directly from descriptions of the vulnerabilities identified in the system. A representation of a sample CECA model analysed in [12] is given below. The first column reflects a linear chain of causes, being the *risk factors* and the second column shows system *vulnerabilities* (weaknesses) responsible for the propagation of the harmful interactions towards the target disadvantage. The last column indicates candidate solution ideas created by *inverting* the vulnerabilities, which seems to follow the idea of *negation of unwanted action* originally devised in [10], although the vulnerabilities are described as properties, rather than actions.

risk factor

tire rides over a sharp object
 sharp object is stuck into tire
 there is a hole in the tire
 the tire is depressurized
 vehicle stops because of a flat tire
 (target disadvantage)

vulnerability

tire allows the sharp object to stick in
 tire allows the object to penetrate
 tire allows the air to come out
 tire requires pressured air for operation

negated vulnerability

⇒ externally shielded tire
 ⇒ internally reinforced tire
 ⇒ self-sealing tire
 ⇒ run flat tire

3.3 Logical negation and state machine model

Logical negation is also important for a state machine CECA representation [16, 17]. Let us consider a model that activates target disadvantages only if the 3 contributing causes appear in a predefined order: first *a*, then *b*, then *c*. This translates into the following sequence of causes: $a \rightarrow ab \rightarrow abc$, which resembles the operation of a 3-input Priority AND (PAND) gate used in Fault Tree Analysis. A respective state machine diagram is shown in Fig. 2. State A models the initial context, when all the contributing causes are inactive, and the automaton remains in this state until cause *a* is activated (but not *b* and not *c*). Then the transition to state B is activated, the automaton waits for condition *ab* (but not *c*), transits to state C, waits for *abc* condition, and finally reaches state D.

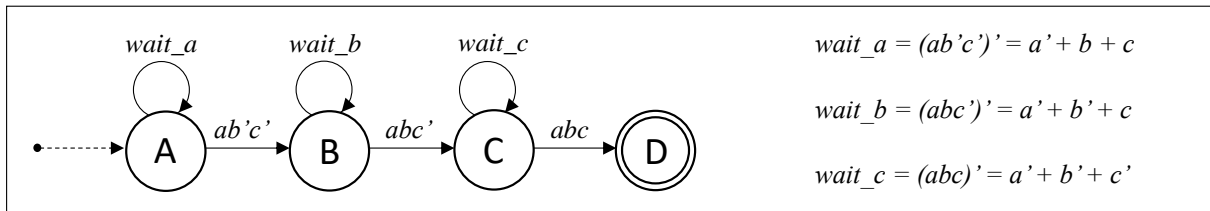


Fig. 2. State machine model of a 3-input PAND gate and the looping functions calculated using negation

If at any given moment none of the transition conditions are satisfied (i.e. all of them evaluate to false), the automaton should remain in the current state. This implies that the “wait” condition is complementary to all transitions and therefore it should be calculated as the negation of OR-ed exit conditions (due to simplicity of the example states A, B and C have only one exit condition each). As can be seen, the negation may appear in state machine models in conditions guarding transitions between states and it is used for calculating wait conditions.

3.4 Complementary conditions in digital domain

Let us start with an example of a simple bi-stable switch for selecting operation mode between AUTO and MANUAL. It seems promising at first glance, as there are exactly two values available and exactly one of them is to be active at any given moment. As the settings appear complementary, one may attempt to replace the condition *mode is set to MANUAL* with *mode is NOT set to AUTO*. But switches vary in construction: for *Break Before Make* type none of the modes is selected during switching period, and for *Make Before Break* type both of the modes are selected then.

Moreover, the switch may be damaged, so if we use a single digital signal line to encode its state, then some fault conditions would be indistinguishable from regular operating conditions. Properly designed device should be able to recognize a fault condition from correct settings. This might be accomplished by sensing the switch position using two digital lines instead of one, with specific combinations (e.g. 01 and 10) assigned to AUTO and MANUAL and interpreting the remaining combinations as faults or transient states. This example shows that controls which look binary at the application (business) level may be multi-valued at the implementation (technical) level, which precludes, or at least complicates, the use of logical negation.

3.5 Complementary conditions in analogue domain

The concept of complementary conditions also generates some pitfalls for analogue parameters. Firstly, testing if a continuous parameter is equal to (or not equal to) an exact value is imprac-

tical, because real measurement devices provide results deviated from actual value by systematic and random errors. Consequently, a condition written as *parameter = value* should be understood as $parameter \in \langle min\ value; max\ value \rangle$, where the range results from accuracy and precision of the measurements. Secondly, similar ambiguity also applies to computer programs comparing numbers in a floating-point representation: instead of testing if one real number equals another, it should be tested if the absolute value of the difference of the numbers is less than a predefined threshold.

Finally, changes in the real world are not “binary” and the conditions appearing to be complementary at the macro-level are manifestations of processes taking place at the micro-level. For instance: a metal element falls off the heated magnet when *sufficient part* of it loses ferromagnetic properties, so that the observed on / off condition is a result of a continuous process of heat transfer that changes the balance between magnetic field and gravity due to a specific Curie point of the alloy used.

3.6 Negation and quantitative approach

Considerations regarding the fusion of the quantitative extensions with logical CECA model are presented in [14]. As for an AND operator it is sufficient to eliminate any of the contributing causes, quantitative parametrization of the model supports selection of the most profitable options systematically. Moreover, the criteria may be adjusted for a specific situation, e.g. to indicate the cheapest solutions (in terms of implementation investments), the safest solutions (in terms of risk), the fastest solutions (in terms of time to market), etc.

For an OR operator, in turn, all contributing causes must be eliminated to remove the target disadvantage, which seems to leave no room for improvement. But sometimes also a reduction of the harm caused by a disadvantage is an acceptable solution, as stated in section 4 of CECA methodical theses [8]. It has been also observed, that majority of the effects usually come from small subset of causes, which is known as *Pareto principle*. Therefore, quantitative model parametrization may be used to identify the most impactful or the most frequent causes, which should be removed first in order to reduce the undesired effects significantly.

Logical negation may also be applied to causality model with quantitative parametrization, but this requires slightly different approach. As shown in the previous section, negating a logical condition is equivalent to applying complementary values or settings. On the other hand, importance of the causes may be related to the intensity or *empirical probability* of their manifestations in the process of development of the disadvantages. And because the position and the negation of a condition must jointly cover all possibilities, then their probabilities may be expressed as p and $1-p$.

The fusion between the qualitative approach (logical functions) and the quantitative description is illustrated in Fig. 3 on the next page. Respective probabilities may be calculated as it is stated below – note the special cases resulting in the simplification of the expressions. The symbol $P(A/B)$ denotes conditional probability of A given B, such as: $P(A/B) = P(A \cap B) / P(B)$.

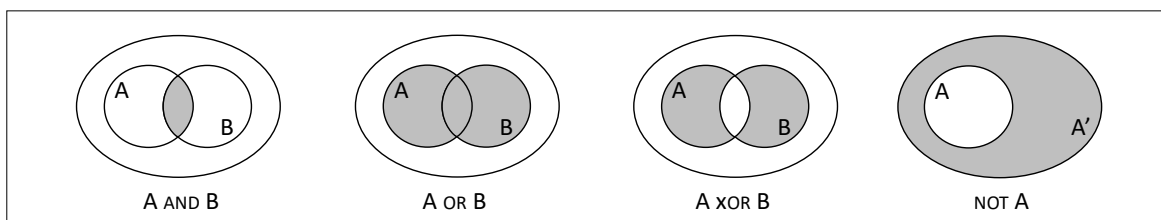


Fig. 3. Graphical representation of logical AND, OR, XOR and NOT

- **AND:** $P(A \cap B) = P(A/B) P(B) = P(B/A) P(A)$
 $P(A \cap B) = P(A) P(B)$ if *A and B are independent, i.e. $P(A/B) = P(A)$*
- **OR:** $P(A \cup B) = P(A) + P(B) - P(A \cap B)$
 $P(A \cup B) = P(A) + P(B)$ if *A and B are mutually exclusive, i.e. $P(A \cap B) = 0$*
- **XOR:** $P(A \oplus B) = P(A) + P(B) - 2 P(A \cap B)$
 $P(A \oplus B) = P(A) + P(B)$ if *A and B are mutually exclusive*
- **NOT:** $P(A') = 1 - P(A)$

3.7 Mutually exclusive conditions and categorization

As it was shown in section 1.3, complementary conditions are special case of mutually exclusive conditions, i.e. conditions that never evaluate to true at the same time. This property may be explored in order to decompose CECA analysis (and thus partition the resulting graph respectively), by describing the different states of the examined system separately. Any attribute can be used for these purposes, as long as it may be described with mutually exclusive categories, e.g. *in use / in service* or *moving forward / moving backward / stopped*, etc.

Even if such categorization does not enable direct minimization, it may enhance the analysis by supporting better focus of the team members. It should be also noted, that in order to keep the model complete, the identified conditions should cover transient states as well, so that *accelerating* and *decelerating* should be supposedly added in the latter example, referring to a movable object.

The mutually exclusive (non-overlapping) conditions are graphically illustrated in Fig. 4, together with other combinations of conditions. The first picture reflects a situation where $A = B$, so the shapes are fully overlapped and the last one illustrates the complementary conditions, i.e. $A = B'$. Identity and negation determine the extremes and the intermediate configurations fall in between. As can be seen, the leftmost configuration is non-contradicting, while the nested and the partly overlapped conditions may or may not remain in conflict, depending on the selection of particular values from the respective subsets. The mutually exclusive conditions appear in the two rightmost pictures, hence both these situations allow for indicating strict contradictions. This summarizes the discussion about the relations between conflict, contradiction and logical negation.

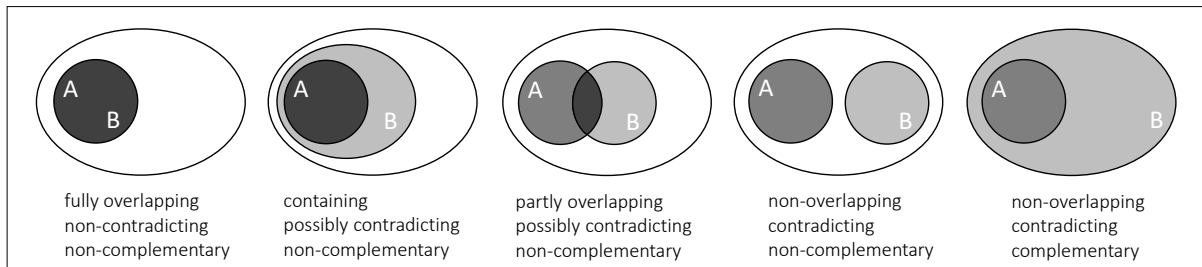


Fig. 4. Various combinations of conditions – from identical to contradicting and complementary

4 Conclusions and further work

This paper provides a brief overview of the use of negation in TRIZ, with particular focus on cause-effect analysis and differentiating negation from conflict and contradiction. Logical negation, perceived as a Boolean function, has been shown with application to the basic combinational CECA model, the vulnerability-based combinational CECA model as well as the sequential (state machine) CECA model. The formal criteria for considering two logical conditions as complementary have been indicated, together with a few technical examples, referring to the digital and analogue signals as well as computer software. Finally, the rules of merging the quantitative results of cause-effect analysis with the logical models have been presented, with the extensions covering complementary conditions and references to empirical probability as a measure of the relative impact of the contributing causes.

The following guidelines are proposed for using logical conditions in the CECA models:

- conditions containing qualitative descriptions (e.g. “insufficient” or “excessive”) implicitly refer to certain contexts, and for complementary conditions the contexts must be identical or the conditions should be made context-free by referring to values of specific parameters,
- context unification (or removal) is also necessary for determining relations between the conditions to recognize if they are identical, nesting, overlapping or non-overlapping.
- identical conditions may be used for combining or synchronizing effects documented in the different parts of the diagram, because either none or all of them would appear,
- mutually exclusive conditions may be used for separating operation modes or contexts of the analysed system in order to keep the partial models compact and comprehensible,
- for discrete parameters complementary conditions unequivocally identify separate states for binary settings solely (which seem to appear relatively rarely),
- for multi-valued discrete parameters at least one of the complementary conditions represents several indistinguishable states, possibly including transient and / or fault states,
- for continuous parameters measurement results should be considered taking into account limitations of measuring devices and numerical representation of values,
- recommended complementary conditions for continuous parameters are: *less than vs. greater than or equal to* and *greater than vs. less than or equal to* or *inside range vs. outside range* rather than *equal to vs. not equal to*.

The empirical probability perspective merges the quantitative description with the logical relations and it generalizes earlier author’s attempts in this area. Hence, whenever we are able to estimate relative intensity of a cause (p) described with a logical condition, it is also possible to calculate intensity of the complementary condition ($1-p$). This may be used for annotating importance of the disadvantages reflected in a CECA model and supporting the selection of the key disadvantages.

The original idea of converting the cause-effect model into a set of the Boolean functions was inspired by the similarities between CECA diagrams and diagrams of digital switching circuits. This conversion allowed for applying some of the techniques used in digital design area, such as logical minimization. Therefore, in addition to the negation itself, the applicability of inverted functions and *don't care* value concept in the cause-effect analysis seems to be an interesting subject for the future research.

Acknowledgements

Author gratefully acknowledges Mr. Dariusz Burzyński for his linguistic support.

References

1. Litvin S., Petrov V., Rubin M., Fey V. "TRIZ Body of Knowledge", MATRIZ 2008. [online] <https://matriz.org/auto-draft/triz-body-of-knowledge-final/>. Last seen on June 30, 2019.
2. Souchkov V. "Glossary of TRIZ and TRIZ-related terms, version 1.2", MATRIZ, 2018. [online] <https://matriz.org/triz-glossary/>. Last seen on June 30, 2019.
3. Ikovenko S. "MATRIZ Level 3 Training", 2018.
4. Chrzęszcz J. "From Problem to Objective – Complementing TRIZ with NLP". In: Souchkov V. (ed.) Proceedings of the TRIZfest-2017 International Conference. Krakow, Poland, pp. 168-177. MATRIZ 2017.
5. Dobrusskin C. "On the identification of contradictions using Cause Effect Chain Analysis". Proceedings of ETRIA World Conference TRIZ Future 2015. Berlin, Germany, 2015, pp. 221-224.
6. Chrzęszcz J., Salata P. "Cause-Effect Chains Analysis using Boolean algebra". In: Koziółek S., Chechurin L., Collan M. (eds.) Advances and Impacts of the Theory of Inventive Problem Solving. The TRIZ Methodology, Tools and Case Studies, 2018, ISBN 978-3-319-96531-4, pp. 121-134.
7. Yoon H. "Occasion Axis and Parameter-Function Pair Nexus for Effective Building of Cause Effect Chains". In: Souchkov V., Kässi T. (eds.) Proceedings of the TRIZfest-2014 International Conference, Prague, Czech Republic, pp. 184-194. MATRIZ 2014.
8. Litvin S.S., Akselrod B.M. "Cause-Effects Chains of Undesired Effects, Methodical Theses" (in Russian). CPB, 1996.
9. Abramov O., Kislov A. "Cause-Effect Analysis of Engineering System's Disadvantages, Handbook on Methodology" (in Russian), Algorithm, Ltd., 2000.
10. Ponomarenko A.I. "Selecting Tasks Using the Operator of Negation of Unwanted Action" (in Russian). Journal of TRIZ, 1995, No. 1, pp. 51-53.
11. Pinyayev A.M. "A Method for Inventive Problem Analysis and Solution Based On Why-Why Analysis and Functional Clues". TRIZ Master Thesis, 2007.
12. Pavlov V.V. "Method for Building a Map of Key Problems" (in Russian), 2001. [online] <http://www.triz.natm.ru/articles/pavlov/pavlov01.htm>, Last seen on June 30, 2019.
13. Efimov A.V. "Identification of Key Disadvantages and Key Problems using Cause-Effect Chains of Undesired Effects" (in Russian), 2011. [online] <http://www.metodolog.ru/node/993>. Last seen on June 30, 2019.
14. Chrzęszcz J. "Quantitative approach to Cause-Effect Chains Analysis". In: Souchkov V. (ed.) Proceedings of the TRIZfest-2017 International Conference. Krakow, Poland, pp. 341-352. MATRIZ 2017.

15. Chrząszcz J. “Indicating System Vulnerabilities Within CECA Model”. In: Mayer O. (ed.) Proceedings of the TRIZfest-2018 International Conference, Lisbon, Portugal, pp. 31-37, MATRIZ 2018.
16. Chrząszcz J. “Modelling CECA diagram as a state machine”. In: Cavallucci D., DeGuio R., Koziołek S. (eds.) Automated Invention for Smart Industries, 18th International TRIZ Future Conference TFC 2018 Proceedings, IFIP AICT, vol. 541, 2018, ISBN 978-3-030-02455-0, pp. 302-314.
17. Chrząszcz J. “Exploring state machine CECA model”. To be presented during 19th International TRIZ Future Conference TFC 2019, Marrakesh, Morocco.

Communication

Communicating Author: jch@ii.pw.edu.pl

TRIZfest 2019

September 11-14, 2019. Heilbronn, Germany

MY FIRST LONG-TERM TRIZ-BASED PROJECT IN HEILBRONN

Ahmad-Ramez Kassou

NPK-Consulting, Moscow, Russian Federation

Paper Classification:

- Best practices, business experiences, integration with non-TRIZ methods/tools
- Case study

Abstract

In March 2009, one-year innovation consulting project for given short-to-mid term objectives was implemented at a manufacturing company in auto industry (located in Untergruppenbach, Heilbronn district). This cost-reduction project included a vital part - technical investigation of specific electro-mechanical product lines – models of a vehicle transmission (gearbox), performed via IoD approach (TRIZ-based methods) of Purchasing Chessboard™ strategy [1]. The article overviews roadmap, phases and main characteristics of that project, with additionally extracted business risks and recommendations for similar practices.

Keywords: TRIZ Toolbox, Invention-On-Demand (IoD), Purchasing Chessboard™, Project, Roadmap.

1 Project

Cost-reduction expertise (due diligence consulting)

In terms of developing engineering systems, this project belongs to “Design-to-cost” type of innovation processes (or Cost reduction TRIZ-based project [2]) and had some vital features which built the successful story:

- Deep slow iterated and repeated process of knowledge transfer (Engineer-to-TRIZ Expert; TRIZ Expert-to-Engineer).
- Tight and continuous collaboration with procurement consultants and business analytics. Intermediary checkpoints with top-managers.
- Business cases built and evaluated (substantiated) at the end of technical research to match given business and commercial targets (e.g. % of reducing the cost of systems/subsystems/components within 2 or five years).

- It was normal not to deliver a WOW-effect to the Client at the end of project (the percentage of cost reduction is predicted and regulated without any extra values). But this effect might be provided during the process of developing engineering concepts, sometimes competing with existing on-site engineering practices, experience etc.

The challenge of developing technical innovation in combination with reaching aimed commercial targets faces complicated administrative restrictions when the TRIZ expert attempts to estimate accurately the found feasible opportunities of product designing (a huge amount of variations and concepts generated by multiple solving directions which should be verified by multiple departments and stakeholders).

After determining the strategy of project development (In our case it was via applying multiple approaches of Purchasing Chessboard™, including IoD, see Fig. 1.), the roles of project team were distributed and pushed in parallel processing. That means, each team member has his(or her) own developed sub-project (TRIZ-based project pipeline was defined as well, see Fig. 2)

High								
8	Invention on demand	Leverage innovation network	Functionality assessment	Specification assessment	Value chain reconfiguration	Revenue sharing	Profit sharing	Strategic alliance
7	Core cost analysis	Design for sourcing	Product teardown	Design for manufacture	Supplier tiering	Sustainability management	Project based partnership	Value based sourcing
6	Vertical integration	Intelligent deal structure	Composite benchmark	Process benchmark	Collaborative capacity management	Virtual inventory management	Total lifecycle concept	Collaborative cost reduction
5	Bottleneck management	Political framework management	Product benchmark	Complexity reduction	Visible process organization	Vendor managed inventory	Supplier development	Supplier fitness program
4	Sourcing community	Buying consortia	Cost data mining	Standardization	RFI/RFP process	Expressive bidding	Total cost of ownership	Leverage market imbalances
3	Procurement outsourcing	Mega supplier strategy	Master data management	Spend transparency	Supplier market intelligence	Reverse auctions	Price benchmark	Unbundled prices
2	Compliance management	Closed loop spend management	Supplier consolidation	Bundling across generations	Make or buy	Best shoring	Cost regression analysis	Factor cost analysis
1	Demand reduction	Contract management	Bundling across product lines	Bundling across sites	Global sourcing	LCC sourcing	Cost based price modeling	Linear performance pricing
Low	A	B	C	D	E	F	G	H
	Low							High

Source: A.T. Kearney

Fig. 1. Purchasing Chessboard™

As any other type of project this one started with a data gathering sessions with stakeholders/engineers and by “living” in manufacturing/testing zone. Then, the data gathering repeated 2-3 times during the process of verifying key disadvantages and problems.

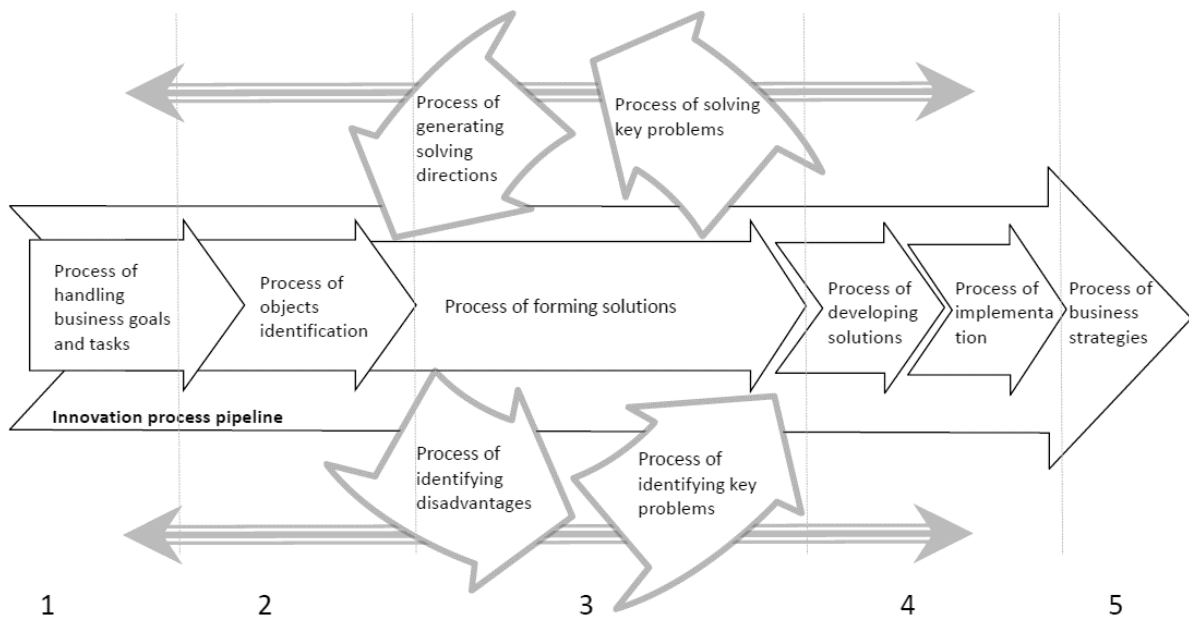


Fig. 2. High-level project roadmap of TRIZ involved partition

The main TRIZ analytical toolbox is located in phases 2-3. Other procedures are complementary and can be combined with other non-TRIZ methods and fields, e.g. business analysis, commercial investigation, lean approach, etc.

The processing cycle of phase 3 (problem identification and solving) in reality was much more complicated in accordance to the complexity of systems/subsystems (high level-to-low level disadvantages and resources). Here, it is significant to realize that the incremental cost reduction findings traditionally lie within small elements which are used for multiple purposes simultaneously and frequently. So, the inventory analysis was required behind the component analysis to decide which degree/characteristics of function modelling had to be designed and handled.

2 TRIZ relation

In this project up to 3 product lines were selected to consider their evolution and cost improvement. Manual and automatic transmission products have various complexity of subsystems, applied technologies and sciences. This complexity of systems was studied and clarified by performing component modelling (see Fig. 3.) and function analysis (see Fig. 4.). A long list of hierarchically ordered internal technical disadvantages and key problems was extracted and formulated and comprehensively described to go ahead with solving tools (mainly through general scientific problem/solution toolbox).

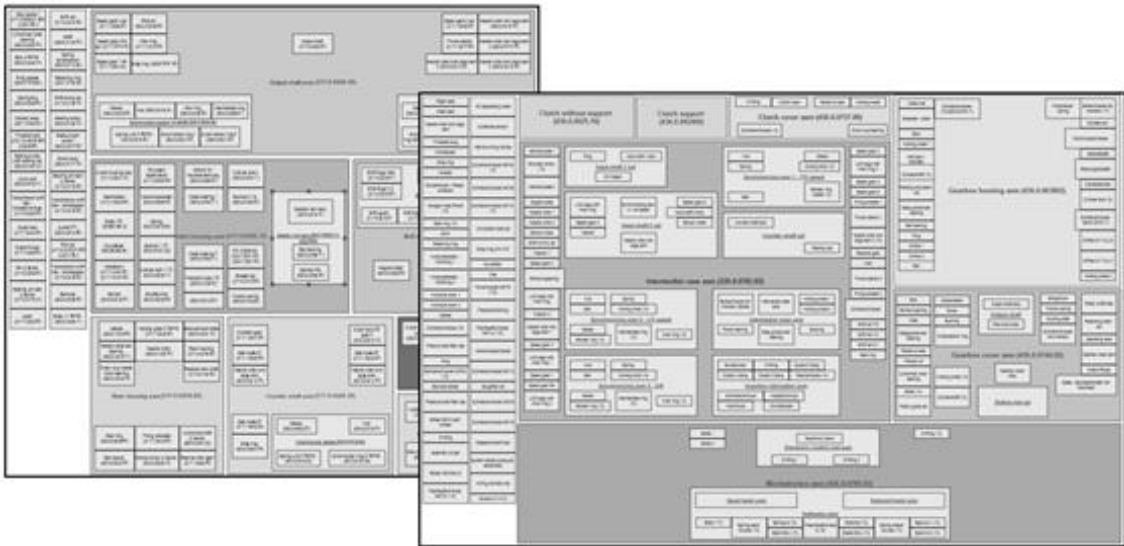


Fig. 3. The complexity of subsystems and component structures (Sample)

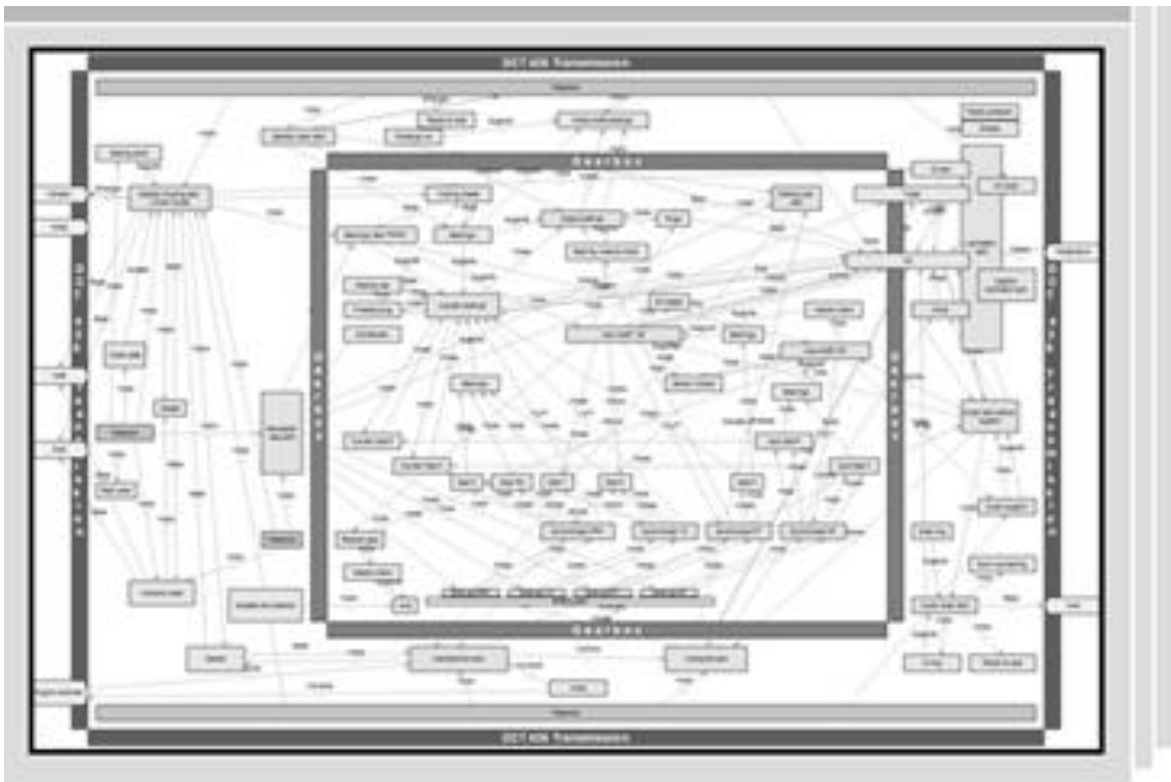


Fig. 4. The complexity of function modeling (Sample)

The function analysis enabled starting the cost analysis of elements/functions at the beginning of innovation process (see Fig. 5.)

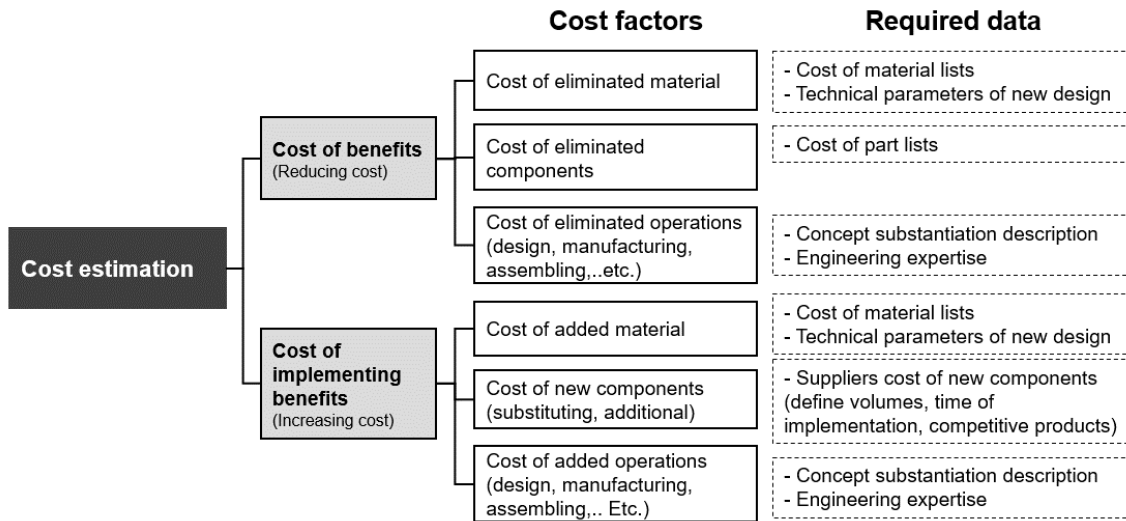


Fig. 5. “Design-to-Cost” estimations

At this stage it is not so significant to consider accurate data of cost estimations which should be approved by financial documents. This accuracy, as mentioned before, will be required in final phase (during filtering generated and well-described concepts).

Hundreds of elements (components with systems) had tens of interconnecting disadvantages had to be sorted, ranged and simplified to enable the generalizing approach. Formulating contradictions here also had a specific use, the dramatic and radical ones should be rare and which can solve common tasks of all considered product lines simultaneously. This might ensure that the developed long-term solutions will be valuable for Client’s business strategy.

3 Results

Describing the innovation process (see Fig. 6.) provides a platform for coordinating connecting sub-processes with activities of other team members.

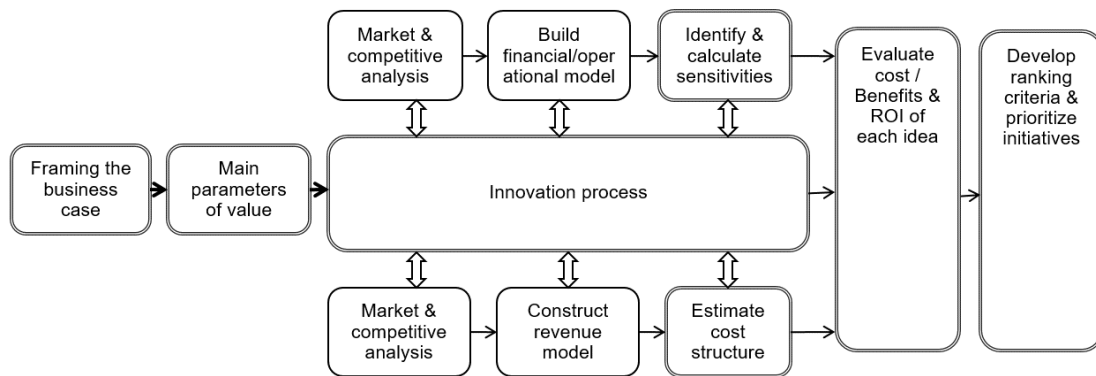


Fig. 6. Innovation project roadmap in terms of processing

The innovation process handles an amount of generated solving directions, then checks their feasibility, and the same for generated concepts (see Fig. 7.). The arguments and parameters behind such filtration will fix the time category of implementation.

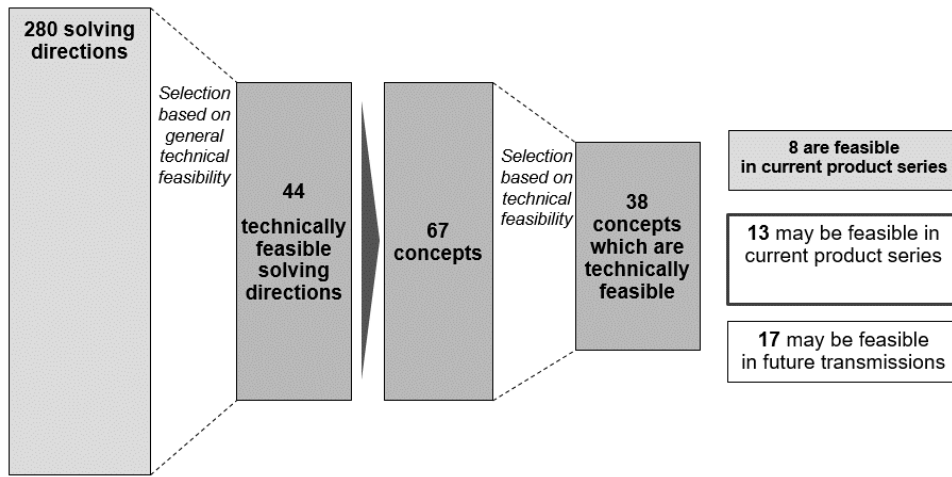


Fig. 7. Process of filtering concepts

Project deliverables are then divided into three categories: Business cases with detailed cost-benefit analysis for immediate applications (Up to 5 concepts); Business cases with detailed cost-benefit analysis for applications with potential for current series (Up to 10 concepts); Report on long-term strategies (Up to 20 concepts).

The output of such innovation process is a set(s) of well-described concepts with mapping on time-scale diagram of implementation (see Fig. 8.). The map is flexible enough to tune the position of each concept to reach the final verified state.

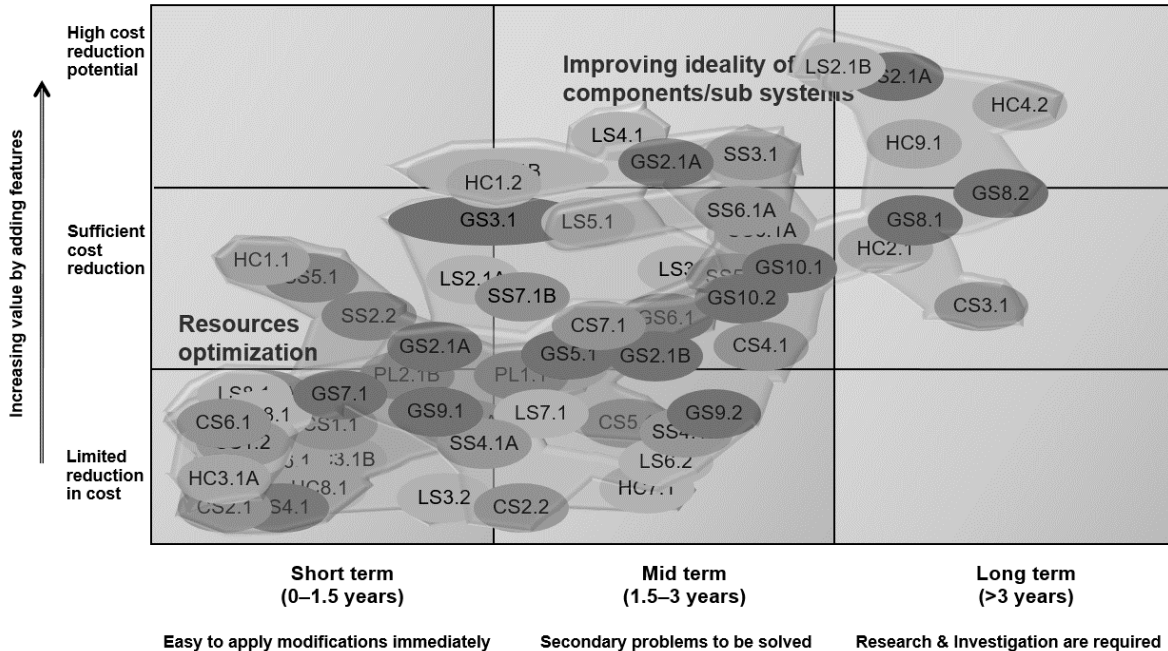


Fig. 8. Cost reduction strategies and box of solutions

To meet the business targets, it is not only reasonable but obligatory to build business cases with accurate ROI data, and then snapshots to present the most impressive and valuable ones.

In our project, the business cases of feasible concepts in current product series are formed using unified and clear template (see Fig. 9.).

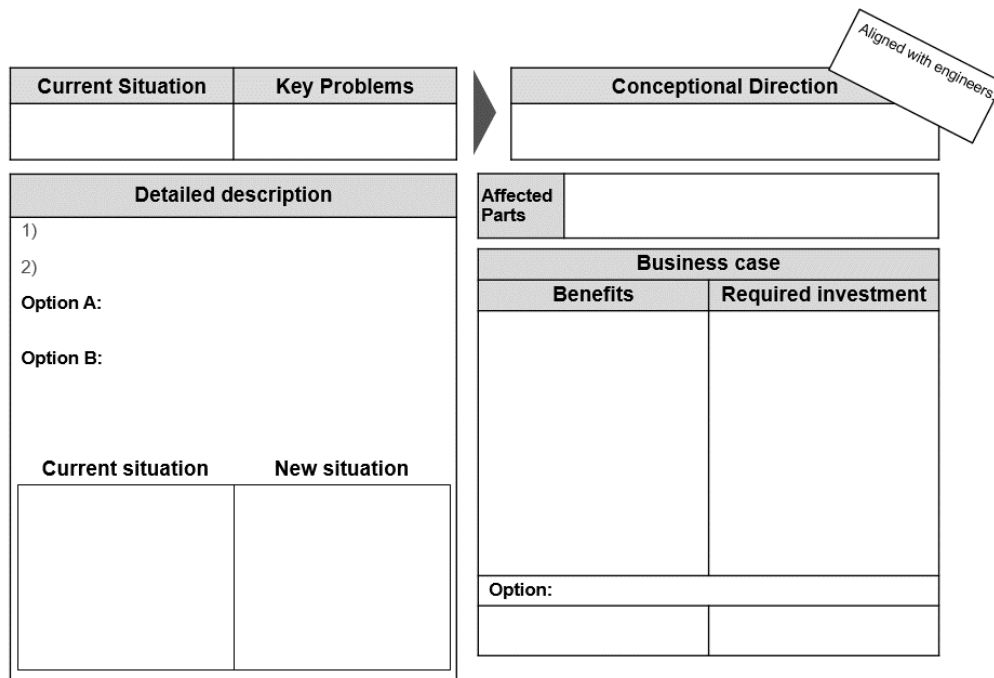


Fig. 9. Template for presenting final business cases of short-term solutions

At the end, here are some aspects and issues which should be considered by project managers to deliver the achieved technical success.

4 Conclusions

The project risks (to be recognized and compensated beforehand):

- Losing hidden values (for example MPV's) while analyzing complicated structures and huge function models.
- It is almost impossible to substantiate solutions of short-to-mid term objectives (incremental and continuous cost reduction) in high-tech industrial fields, if they are extracted through radical TRIZ-based methods (e.g. radical trimming, IFR, solving powerful contradictions and others).
- The lack of sharing WOW-effects on project checkpoint meetings. Most of concepts are logically extracted, calculated and strongly filtered by business analytics (of both client and their consultants).
- Global ones: E.g. Effects of financial crisis, events of regional economy, changes in company policies, strategies etc.

Factors of success and recommendations:

- The key engineering personal should be involved and motivated in developing the list of key disadvantages/problems/solving and even in presenting concepts. The motivation here is obtaining new analytical skills of innovation.

- Increasing as much as possible the amount of workshops and data gathering sessions in production zones (normally this opportunity is limited to outsiders)
- Improving the level synergy within client's internal processes and representatives (people, sites, management services) can be enabled through projecting via existing engineering environment/approaches/facilities.

References

1. Purchasing ChessboardTM. <https://www.atkearney.com/web/the-purchasing-chessboard>
2. MATRIZ – Level 1 Training Manual. <https://matriz.org/wp-content/uploads/2019/01/Level-1-Manual-Word.pdf>

Communication

Communicating Author: ramsess2@protonmail.com

TRIZfest 2019

September 11-14, 2019. Heilbronn, Germany

PATENT CIRCUMVENTION AND PORTFOLIO DESIGN BASED ON INITIAL DISADVANTAGES IDENTIFICATION AND CAUSE EFFECT CHAIN ANALYSIS

Yongwei Sun, Yinhua Long, Shaodan Ma

NICE (National Institute of low-carbon and Clean Energy), China Energy Group

*NICE, Future Technology City, Xiaotangshan, Changping District, Beijing, China
(102209)*

Abstract

In this article, a new patent circumvention approach is proposed. Normally, the purpose of the existing patents is for certain problems solving. However, there may be many problems in the projects. The existing patent may focus on only one or very few problems. By identifying the initial problem and then dig deeper with Cause Effect Chain Analysis, we may find much more hidden problems. By solving the identified “new” problems we may generate new solutions which can be used to achieve the same goal or remove the initial problems. The new solutions are very different from the existing patent, and therefore, they will not infringe the existing patent. This approach can be used for either for patent circumvention or patent layout.

Keywords: *patent circumvention, initial disadvantages, obvious disadvantage, cause effect chain analysis*

1 Background

Patent circumvention is a very hot topic in many industries and in many countries, especially in China. There are many ways to circumvent the existing patents, such as trimming, substitution, etc. However, each of the approach has their own disadvantages. For example, if we try to use trimming, we may find it is not easy to find the new carrier to maintain its useful functions performed by the trimmed components, which made the approach very difficult to implement. Even we can find the new carrier, sometimes it is difficult to solve the secondary problem of how to make the new carrier to sufficiently perform the function. For the substitution approach, which means substitute certain components of the existing patent with new components, it also has the even bigger risk of infringing the existing patents through doctrine of equivalent. Julian F.J. proposed a patent circumvention strategy based on TRIZ on 2013, by 1) Removing unnecessary elements; 2) removing the types of limitations; 3) removing potential disadvantages.[1] However, in practical problem process, in many cases, the initial disadvantages are not clear enough which made the team members achieve the wrong project goals.

We propose a new patent circumvention and patent portfolio design approach by identifying the initial problems and then Cause Effect Chain Analysis.

2 Judgment of patent infringement

Before we propose the new patent circumvention approach, it is necessary to list the criteria of patent infringement. Patent laws of different countries are slightly different, but the main criteria are almost the same. For example, we have the following situation. In an existing patent, it is claimed that the system consists of A, B, C, and D. The table below listed the new solutions and their possibilities of infringement.[2]

No.	Concept	TRIZ tools	Infringement
1	A, B, C, D		Yes
2	A, B, C, D, E		Yes
3	A, B, C	Trimming	No
4	A, B, C, E (E=D)		Yes
5	A, B, C, E (E≠D)	Function Oriented Search, Scientific Effects	No
6	E, F, G, H	Initial Disadvantages Identification; Cause Effect Chain Analysis, etc.	No

In this article, we will mainly focus on approach 6. In that approach, E, F, G, H concept is so different from the original concept, A, B, C, D. And therefore, there will be no infringement. The reasons of why the new concept is different from the original one is that the new concept does not solve the same problem of the original patent, it tries to solve a totally new problem in the project.

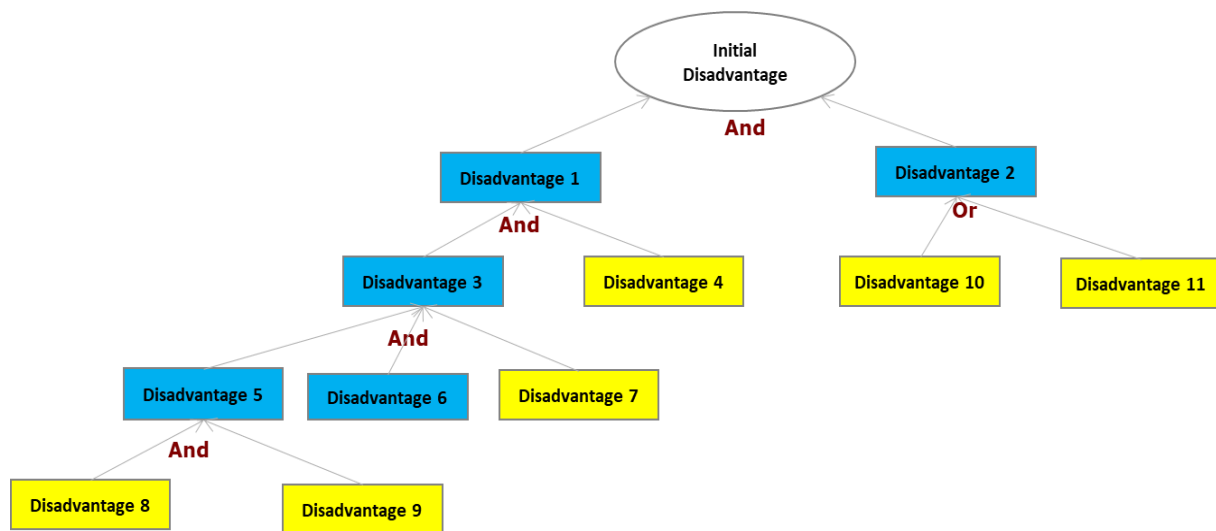
3 Review of Initial Disadvantage Identification

In my article of initial problems identification of 2017, I proposed an approach of finding the right initial problems, which are very helpful in many practical projects. (*Initial Disadvantages Identification*, the 13th International Conference Proceedings (TRIZfest 2017), p217-221, 2017, ISSN: 2374-2275 ISBN: 978-0-692-52418-3) In the article, an approach was proposed about how to identify the initial disadvantages. By definition, the initial disadvantage is the opposite of project goal. And there is an algorithm of how to identify the initial disadvantages step by step.

1. Select a starting disadvantage (N), normally it is an obvious one in the project. It is not difficult to find a starting disadvantage;
2. Find disadvantage (N-1) by figuring out what starting disadvantage (N) may bring to the project, instead of identifying the underlying causes;
3. Repeat step 2 until you find the disadvantages that are almost irrelevant to the project goal. Those disadvantages are the initial disadvantage candidates;
4. Compare the initial disadvantage candidates and determine the most suitable one as the initial disadvantage;
5. Build cause effect chain from the initial disadvantage.

4 How to circumvent patents with the initial disadvantages identification and CECA?

If we read the patent, in the main body part, there is problem statement part. Normally, it will describe what problem the patent will try to solve and its corresponding disadvantages. But those disadvantages may not be the initial disadvantages. They can be the initial disadvantages, intermediate disadvantages or end disadvantages. The picture below shows those 3 disadvantages. The top one is the initial disadvantage, the yellow ones are end disadvantages, which means it meets the requirements where the cause effect chain should stop, and the blue ones are intermediate disadvantages between initial disadvantages and end disadvantages).



In the claim part, it describes the solution the inventors want to protect. If we read the claims carefully, it is not difficult to find it is the solution proposed for removing certain disadvantages in the cause effect chain. For example, the *Disadvantage A* is the one the claimed solution tried to remove. If *Disadvantage A* can be removed, the initial disadvantage could be eliminated or be alleviated. Therefore, the project goal can be either achieved or improved. In fact, normally there are more than one disadvantages in the project. The claimed solution is only for removing one or very few disadvantages. If we can find some other solutions to remove the other disadvantages, for example, *Disadvantage B* or *Disadvantage C, D...*) we can also achieve the same project goal. Because *Disadvantage B, C* or *D* are totally different from *Disadvantage A*, the solutions for removing these disadvantages are also totally different from the claimed solutions. As mentioned in the Judgement of Patent Infringement part, the totally new solutions do not infringe the claimed solutions (Criteria 6). The more disadvantages we can find, the more opportunities we may have and the more solutions we can generate. And therefore, the bigger probabilities we can circumvent the patent.

5 Algorithm for Patent Circumvention by Initial Disadvantages Identification and Cause Effect Chain Analysis

Like the other TRIZ tools, we also developed an algorithm for patent circumvention with Initial Disadvantages Identification and Cause Effect Chain Analysis.

1. Clearly understand the claim part of patent and clearly understand the proposed solutions;
2. Convert the solution to a disadvantage, or identify the disadvantages the claimed solutions tried to eliminate.
3. Follow the algorithm of Initial Disadvantages Identification and find the Initial Disadvantages;
4. Build the Cause Effect Chain from the Initial Disadvantages. The more disadvantages we can find the better. The disadvantage corresponding to the claim should be in the Chain.
5. Find new solutions by traversing each disadvantage in the Chain and don't miss any disadvantage.
6. Compare the new solutions with the claims in the patent to prevent the infringement.

6 How to design patent portfolio with the initial disadvantages identification and CECA?

We just described how to circumvent the patents with initial disadvantages identification and CECA. It can also be used to design the patent portfolio. In many companies, they don't submit only one patent application for a specific technology. Normally, they would like to submit a patent portfolio to enhance the advantages in that area. There is no systematic approach for the patent portfolio design.

We propose a systematic way to design the patent portfolio with Initial Disadvantages Identification and CECA.

In my article, the approach on how to identify the Initial Disadvantages was proposed. By identify the Initial Disadvantages and then build Cause Effect Chain, we can find out all possibilities (or disadvantages) to achieve the project goals (the opposite of the initial disadvantages). We can generate solutions from each disadvantage in the chain. Because we may have solutions from many different disadvantages, and finally we will generate a pool of solutions. In this step, we can use the TRIZ problem solving tools, such as inventive principles, standard solutions, function-oriented search and effects... If we can find more solutions which are patentable, then we can submit those invention disclosures as a portfolio.

7 Algorithm for Patent Portfolio design by Initial Disadvantages Identification and Cause Effect Chain Analysis

Like the Patent Circumvention with Initial Disadvantages Identification and Cause Effect Chain Analysis, there is also an algorithm for Patent Portfolio design.

1. Find the obvious disadvantage in the project;
2. Identify the initial disadvantages;
3. Build Cause Effect Chain;
4. Try to generate new ideas (solutions) with TRIZ problem solving tools;
5. Evaluate the patentability for each solution;
6. Submit patent applications.

8 Case study

In China, the combustion of much high arsenic coal makes the deposition of arsenic compounds in conventional denitrification catalysts extremely high, as high as 2-3%, resulting in catalyst

poisoning and greatly reducing the service life of the SCR catalysts. At present, traditional catalyst regeneration process has very low arsenic removal efficiency, and most of the solutions are about the chemical cleaning solution. There are many patents in this area, such as CN104857998A, CN103894240B and CN105536886A.

By following the Algorithm proposed above, we develop totally new solutions:

1. Clearly understand the claim part of patent and clearly understand the proposed solutions;

Most of the patents are about the chemical cleaning solutions. The difference between them are about the formula and the percentage of the composition.

2. Convert the solution to a disadvantage, or identify the disadvantages the claimed solutions tried to eliminate.

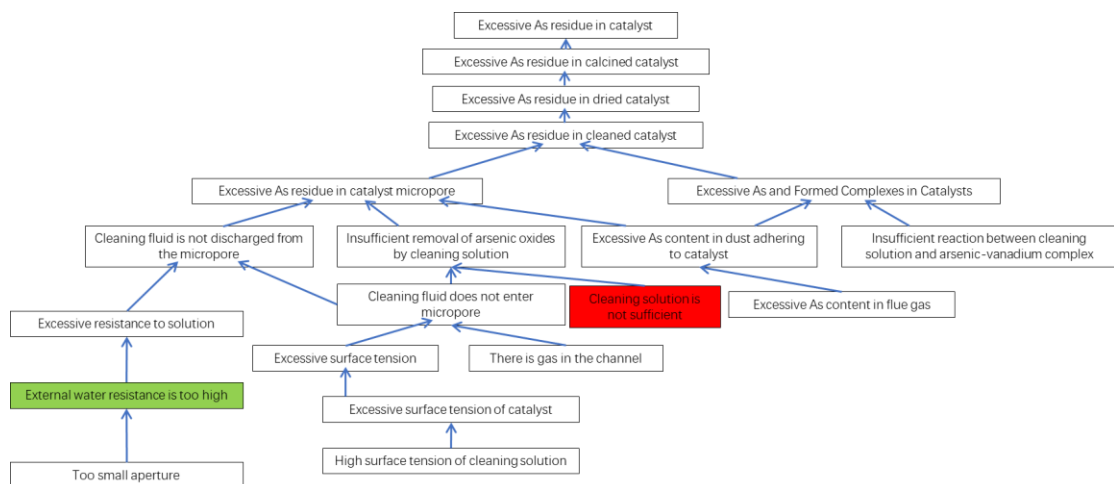
The disadvantage the patents were trying to solve is the cleaning solution efficiency.

3. Follow the algorithm of Initial Disadvantages Identification and find the Initial Disadvantages;

By keep asking the effects caused by the disadvantages from step 2. We found the initial disadvantage. The initial disadvantage is there is too much Arsenic residuals in the catalyst even after recovery process.

4. Build the Cause Effect Chain from the Initial Disadvantages. The more disadvantages we can find the better. The disadvantage corresponding to the claim should be in the Chain.

We built the Cause Effect Chain from the initial disadvantage. There were many more disadvantages found. The diagram below listed the disadvantages we identified from Cause Effect Chain Analysis. One more interesting finding is that we found more patents tried to solve different problems on the chain.



5. Find new solutions by traversing each disadvantage in the Chain and don't miss any disadvantage.

We tried to generate ideas from each disadvantage in the chain no matter it is on the top, middle or bottom. Totally, we generated 15 new ideas. The solution of using the combination of specific frequency of ultrasound (acoustic field), specific temperature (thermal field) and bubbles(mechanical field), etc., was proved to be very effective to remove arsenic. The arsenic removal rate is significantly increased to more than 90%, and the loss of the original active ingredients of the catalyst is minimized, and the mechanical strength of the regenerated catalyst is not significantly reduced, thus

greatly prolonging the service life of the catalyst. This solution has been implemented in our fire power plant.

6. Compare the new solutions with the claims in the patent to prevent the infringement. Since our ultrasound approach is very different from the original chemical cleaning solutions. There is no infringement at all. The new solution was submitted to the China Patent Office as the invention disclosure. Patent application number is CN20170818104051.
7. Patent portfolio design. Beside this solution, we generated 14 other solutions based on each disadvantage. We are submitting more patents which will become a portfolio. For example, invention disclosure has been submitted to the patent office: CN201810136806.1.

9 Summary

We proposed a systematic approach of patent circumvention and patent portfolio design by identifying initial disadvantages and then build cause effect chain. By finding new solutions for each newly identified disadvantage, we can generate new solutions from each disadvantage. Because the new solutions are for totally new disadvantages, most likely the new solutions are very different from solutions which are already in the patent claims. In that way, we can circumvent the original patents. By identifying the initial disadvantages and then build the cause effect chain, we can find solutions for each possible ways(disadvantages) and therefore we can build the patent portfolio.

Of course, beside our approach, there are other ways to build the patent portfolio such as TESE (Trends of Engineering System Evolution) in TRIZ.

References:

1. Patent circumvention strategy using TRIZ-based design-around approaches, Julian F.J. etc, TRIZ future 2013
2. Patent mining, Ma Tianqi, Intellectual Property Press, 2016, ISBN: 9787513044240, 7513044244
3. "TRIZ: The Golden Key to Open the Door of Innovation", Sun Yongwei & Sergei Ikonen, Science Press, 2015.
4. "Initial Disadvantages Identification", the 13th International Conference Proceedings (TRIZfest 2017), p217-221, 2017, ISSN: 2374-2275 ISBN: 978-0-692-52418-3

Communication

Communicating Author: *ywsun@yeah.net; sunyongwei@matrizchina.cn*

TRIZfest 2019

September 11-14, 2019. Heilbronn, Germany

PLAYING AS A WAY TO RESOLVE THE CONTRADICTIONARY DEMANDS. CASE STUDIES REVIEW

Jerzy Obojski,

Novismo Sp. z o.o., Poland

Paper Classification:

- TRIZ-related methods and tools development

Abstract

TRIZ was developed to fill the thinking gaps in technical world. Years later, many other areas of life successfully implemented the power of systematic thinking. Well-organized analytical part of TRIZ and deep understanding of clue of problem can bring many ideas to resolve even stalemate situation.

Initial, contradictory requests are treated as mission impossible within built for many years culture of social paradigm. In this paper author tries to analyse the examples of situations in which people don't want initially perform some activities, but then change their minds due to adding a playful factor to their actions. Relationships between human perception, feeling and rewarding can be an inspiration to intended design of complex systems for delivering both expected results and good feelings of people.

Keywords: *Contradictions, social paradigm, human factor, super effect.*

1 Introduction

In some areas of our lives we strongly believe that it is impossible to change something because this is out of our control. So if we cannot change, for instance, behaviour of strangers, should we stop trying? The answer is, no. We should try to analyse situation, define the boundaries, change their place and observe the new impact. Very often the solution for some case is quite simple, but reason that nobody so far didn't find it is the "ownership". When I know that this is within my area of responsibility, I have motivation to do something. In the opposite situation when I don't know who is responsible for specific area, my enthusiasm reduces. To understand the whole picture of any situation, TRIZ gives us multiple tools for analytical work. These tools facilitate disassembly of "impossible tasks". Many tasks became impossible for a simple reason than someone already failed or because the additional work was needed to accomplish the task. Tools like Function Analysis, CECA, Root Conflict Analysis, Problem Formulator nowadays produce a set of potential directions that focus us in critical points. The origins and main utilisation of those analytical tools was in problem solving activities in different technological areas. For last two decades, TRIZers succeeded in resolving not only the technical issues. Business, advertisement, insurance, medicine, healthy, sales, safety and others domains of human activities have also long list of problems that need resolving.

Here we face a new challenge related to the human behaviour: free will. In technical areas physics, chemistry or mathematics bring us very effective solutions, and the only question is, is it feasible or not. This question could be answered through measurable factors like mass, size, volume, speed etc. But how to deal with humans if the science is not able to predict their behaviour in specific situation? In that case, it is good to use the “soft” knowledge such as psychology. Some contradictory situations could be resolved if the perception of people was be changed. This topic will be explained in detail in the next section of this work.

1.1 Contradiction

Contradiction is a situation that emerges when two opposite demands have to be met in order to provide the required result. A contradiction is argued to be a major obstacle to solve an inventive problem. Hence, it is used as an abstract inventive problem model in the TRIZ tools. Three types of contradictions are known in TRIZ: 1) Administrative, 2) Engineering, 3) Physical. TRIZ states that in order to obtain an inventive (breakthrough) solution, a contradiction has to be eliminated rather than optimized or compromised. [1]

Administrative Contradiction is a description of either a negative (undesired) effect or a necessity to create something new in a situation when neither a problem solving method nor ready to use solution is available.

Engineering Contradiction: a situation in which an attempt to improve one parameter leads to the worsening of another parameter. A trade-off solution, e.g. adding some metal to make a wing somewhat larger but not too much so as not to make it too heavy, does not resolve the Engineering Contradiction, and, thus, fundamentally, is sub-optimal. In contrast, an inventive approach to solving engineering problems would be to resolve this contradiction without compromise: make a wing larger without making it heavier.

A Physical Contradiction is a situation in which two opposite requirements are imposed upon a single parameter of an Engineering System. For example, a hammer should be heavy to improve the quality of nail **penetration**, but the hammer should be light to improve the performance and handling of the hammer. Therefore, to improve the performance and handling of the hammer, its parameter "weight" should comply with two contradictory requirements, i.e., to be light and heavy at the same time. This situation is caused by the conflicting requirements of an Engineering Contradiction.

As an example of this physical contradiction in everyday life we can imagine the following situation: people don't want to run some activity, but they should run it. What happens in people's minds? They feel bad. There is a big difference when I should do something because I want to and when I must.

Let's consider when people usually feel good. Then, we can use this knowledge and reveal how TRIZ could help resolving this conflicting situation. Then, some not ordinary ideas can appear.

The following lists represents the Inventive Principles used to resolve Physical Contradictions in certain situations. [2]

The following principles should be used to separate contradictory demands:

Separation in Space:

- Principle 1 — Segmentation
- Principle 2 — Taking out
- Principle 3 — Local quality

- Principle 4 — “Nested doll”
- Principle 5 — Asymmetry
- Principle 17 — Another dimension

Separation in Time:

- Principle 9 — Preliminary anti-action
- Principle 10 — Preliminary action
- Principle 11 — In-advance “cushioning”
- Principle 15 — Dynamics
- Principle 34 — Discarding and recovering

Separation in Relation:

- Principle 3 — Local quality
- Principle 17 — Another dimension
- Principle 19 — Periodic action
- Principle 31 — Porous materials
- Principle 32 — Color changes
- Principle 40 — Composite material

Separation in the System Level

- Principle 1 — Segmentation
- Principle 5 — Merging
- Principle 12 — Equipotentiality
- Principle 33 — Homogeneity

Satisfying Contradictory Demands

- Principle 13 — The other way around
- Principle 24 — Intermediary
- Principle 28 — Mechanics substitution
- Principle 30 — Flexible shells and thin films
- Principle 35 — Parameter changes
- Principle 36 — Phase transition
- Principle 37 — Thermal expansion
- Principle 38 — Strong oxidation
- Principle 39 — Inert atmosphere

Bypassing Contradictory Demands

- Principle 6 — Multi-functionality
- Principle 13 — The other way around
- Principle 25 — Self-service

All of these principles were created for using with technical systems. Can we easily apply tips like: Thermal expansion, Strong oxidation, Mechanics substitution etc. to humans? At a first glance, it looks impossible. But let’s compare this knowledge with psychological knowledge about behavior people under new conditions and at times of changes.

2 Eyes on the prize

In a new situation, human reactions follow the sequence represented in Change Curve [3]: Denial, Anger, Bargaining, Depression, Acceptance, Experimentation, Discovery and Integration.

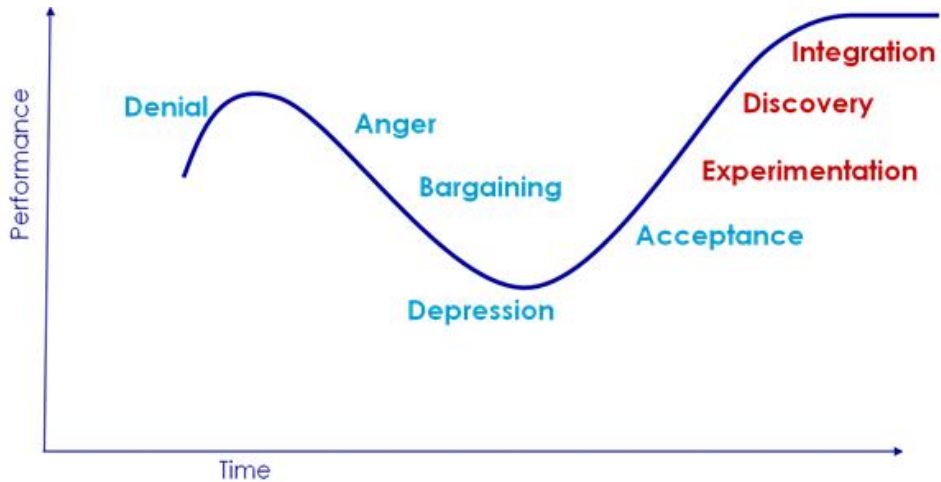


Fig. 1. The Change Curve [3]

When a surprise occurs in the well-known situation, the reactions follow the simpler sequence: Experimentation, Discovery and Integration.

Let's consider the following situation:

Did you know that urinals are actually designed to minimize unwanted splashing? Now, this works best if the stream is aimed to a certain area of the urinal bowl. While the designers go through great length to create this feature, their best effort does not seem to be communicated to the users effectively (or have you ever seen a user manual...?)



Fig. 2. Different shapes of urinals. [4]

It is also hard to tell where exactly this 'sweet spot' is located since urinals come in a surprising variety of shapes and sizes. Therefore, even with the best intention the user lacks the necessary information to use the urinal in an as clean way as possible. In summary, there are many aspects to consider in tackling the resulting problem.

Think for a moment, how would you approach solving this problem? What ideas do you have?

2.1 A solution on the fly

Here is a solution that used playing principles to reduce cost. This solution also facilitates the cleaner facilities, as a “super-effect”.

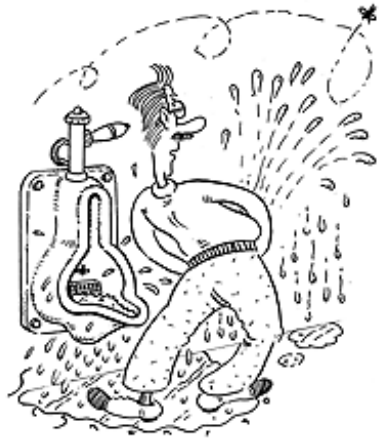


Fig. 3. Urinal spillage problem. [5]

Instead of launching an educational campaign, printing user manuals, imposing fines, or negotiating the lower salaries for janitors, the Dutch came up with an ingeniously simple idea. They placed the picture of a housefly right on the sweet spot in the urinal bowls in male restrooms.



Fig. 4. Housefly solution [Own source].

First, the ‘fly’ was a low-cost peel-and-paste decal. Now it is also available as already etched right into the new bowls by the manufacturer.

This little fly turns the ‘aiming’ handicap into an engaging little game challenge. It appeals to a man’s inner child, as well to deep-rooted hunter instincts. It also becomes a welcome pastime during an otherwise boring routine. It is a very personal and fun activity ‘shooting the fly’! As a results, spillage is reduced by 80%.

More variations of this concept



Fig. 5. Candle, Golf pose, Fire solutions. [Own source].



Fig. 6. Stickers, electronic indicator [6], [7], [8].

2.2 The piano stairs

Another case based on the idea that ‘something as simple as game is the easiest way to change people’s behavior for the better’ is illustrated by stairs challenge case. [9] The aim was to get more people to take the stairs by making it fun to do so. The creators of this challenge asked themselves: “Can we get more people to choose the stairs by making it fun to do?” Stairs located next to escalators were transformed into a working piano, with every step playing a note to the Swedish public.



Fig. 7. Piano Staircase installation (Odenplan station Stockholm).



Fig. 8. Exit from Odenplan train station Stockholm. (Before the change).

The basics of this concept was very simple. Everybody knows how the piano works. The stairs shape is easy to connect to piano keyboard. Stairs looking like piano keyboard and playing the sounds trigger people to prefer the stairs to escalator. Good feeling, smiling and joy are the typical reactions to walking by this gadget. Even people who do not choose the stairs but observe happy peoples on the side will try it for sure in the near future.

This place in relatively short time became famous and popular. Many of Stockholm's tourist attractions are adjacent to this train station with unusual stairs.



Fig. 9. Piano Staircase installation (Odenplan station Stockholm).

Results: 66% more people prefer the stairs to the escalator.

Such fun might really change people behavior. In the case of piano stairs, it works well. Many other similar installations appear soon around the world.

More variations of this concept



Fig. 10. Slide on Berlin Alexanderplatz train station. [10]

2.3 The beer challenge

The effect of good feeling in commercial usage can be illustrated by Czech beer pub called MAMUT. The setup of interior equipment aims at more effective utilization of existing infrastructure. There are dedicated boxes with tables and chairs inside. Each box is equipped with TV display and beer delivery pipe system.



Fig. 11. MAMUT beer pub, Brno, Czech Republic [11]

Beer is delivered directly to the table by tap with electronic counter. Then statistics from all tables is presented in the screen.

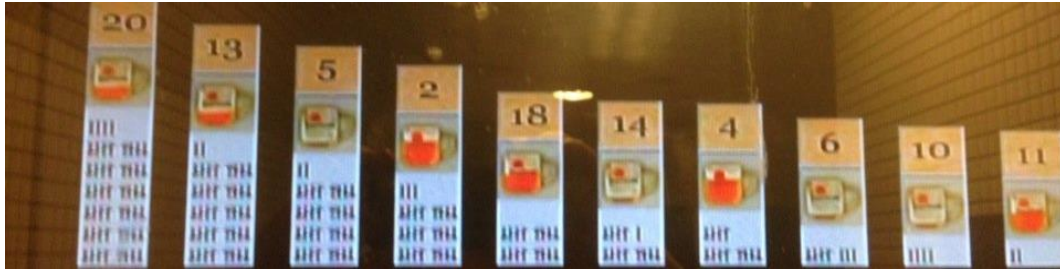


Fig. 12. The visualization of beer consumption each of table. [Own source]

The key of this concept was very smart. Teambuilding atmosphere, competition with other tables, good beer and food make this place unique. There are many motivated, happy and smiling people inside. The climate of competition gently changes the customers' behavior in this pub. People always try to win, so... they drink more and more...

More variations of this concept

BEAT 25 MINUTES AND IT'S FREE!!

[Check Facebook for latest updates](#)

Terms and Conditions

- Meal consists of one 1KG Big Boss Burger from McQueens' 100 Burger menu, a portion of fries and 3 pickles
- Entire meal must be completed (including pickles and fries) in allotted time. If any of the meal is not eaten (swallowed)...YOU LOSE!
- Once you have started, you are not allowed to stand up, leave your table, or have anyone else TOUCH the meal.
- You will be disqualified if anyone assists you in the cutting, preparing or eating of your meal.
- Should you become ill, the contest is over... YOU LOSE!
- You must sit at a table of our choice inside for full supervision.
- If you do not win the 1KG Big Burger Challenge, you are welcome to take the leftovers home with you.
- We have the right to use your name and image on our web site and promotional work.
- If you complete the challenge under the allotted time you will receive the cost of the meal back.
- All applicants must be 18 years of age or older. The applicant further acknowledges and understands that McQueens Management shall decide, at its sole discretion, whether an applicant is eligible to participate in any eating event.
- By signing the waiver, the applicant acknowledges and takes full responsibility for his/her own health risks related to this eating competition. McQueens Tavern cannot be held liable for any bodily harm resulting from the risk taken by the participant in this contest.
- EAT AT YOUR OWN RISK!



Fig. 13. The giant burger [12]



Fig. 14. The giant pizza [13]



Fig. 15. The giant hot dog [14]



Fig. 16. One meter pork rib [15]

3 Results

These case studies demonstrate the potential of using playing principles to convince people performing the expected activities without side effects that usually accompany the changes. Let's compare the typical situation presented on Fig. 17 when peoples don't follow the new rules with a new approach when PLAYING principles are used (see Fig. 18). An intended

switch of human mind becomes apparent in such comparison. Feeling like joy, happiness and pride accompanying the activities strengthen this change even more.

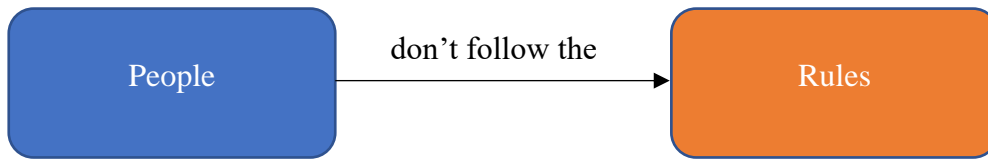


Fig. 17. Typical situation during stage Change.

How to change people minds so that they even don't recognize what was expected? Any action such as education, explanation, training or direct motivation could be taken as a personal attack. Typical reaction follows the change curve behavior: Denial, Anger, Bargaining, Depression, Acceptance, Experimentation, Discovery and Integration. To avoid this sequence, we propose to add PLAYING (surprise, fun, reward, challenge factor).

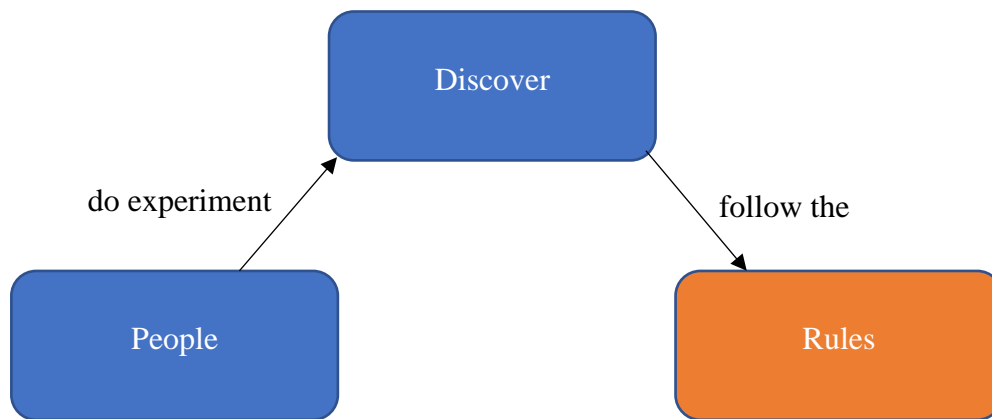


Fig. 18. Using PLAYING principles during stage Change.

This small change focuses human brain to achieve the target, absorb all capacity to get the best result and utilize all experience and knowledge for being the best.

3.1 Link to Inventive Principles

This approach to break the direct link between People and Rules by adding a new stage of Discover is similar to the following Inventive Principles: Segmentation, Taking out, Parameter changes, Intermediary, The other way around, Another dimension or Local quality. For obvious reasons only a few previously suggested Inventive Principles can be used in non-technical problems. With this knowledge, it will be much easier to design a products for areas where human factor is critical for successful achievement of expected result.

Example:

- To better engage kids in tooth cleaning, it is recommended to equip a toothbrush with sensor that, in interactive way with an application, informs about the current status in game.

- For those in need of rehabilitation, the additional motivation could be created by playing to achieve more, better and faster.
- To sell more, you need to prepare an environment to compete, offer a prize and show the best results.

4 Conclusions

There is a growing interest in how playing defined as the application of play design principles to non-gaming contexts can be used in business. However, business research and management practice have paid a little attention to the challenges of how to design, implement, manage, and optimize their own strategies better. To advance the understanding of playing impact, this article defines what it is and explains how to facilitate people thinking about business practice in new and innovative ways. Drawing upon the play-design case studies presented a framework of TRIZ inventive principles, the curve of change and human emotions to explain how playing experiences can be created.

All cases presented in this article may offer a viable starting point and a practical tool for organizations to conceptualize their playful initiatives using a systematic TRIZ approach. The purpose of the framework is to facilitate the selection of technology features and the design of interactive, enjoyable activities that would integrate well with business processes, satisfy end-user motivations, and help driving the positive individual behavior and desired business productivity outcomes that result in meaningful commercial profit.

References

1. Souchkov V. "Glossary of TRIZ and TRIZ-Related Terms". Available: www.xtriz.com/publications/glossary.htm [online]. Last update 2015-08-16, accessed 2019-04-30.
2. MATRIZ – Level 1 Training Manual, pp.53 - 69
3. Kaplan L., Obojski J. "TRIZ problem solving: Consulting vs Facilitation". TRIZ Fest 2017 Conference proceedings, pp. 496 – 507
4. Source: <https://www.cersanit.com.pl>
5. Source: <https://www.straightdope.com/columns/read/2450/urinal-101-aim-for-the-back-wall-or-the-water/>
6. Source: <https://www.ebay.com/itm/Eses-Urinal-Target-Markers-Sticker-Children-Toddlers-Toilet-Training-6-Stickers-/2833848856831>
7. Source: <https://orgchanger.com/2012/11/01/a-splash-of-innovation/toilet-marksman-sticker/>
8. Source: <https://gizmodo.com/pee-pro-urinal-target-turns-your-toilet-into-a-carnival-5947312>
9. Source: [https://goodvertising.site/the-fun-theory/Piano stairs](https://goodvertising.site/the-fun-theory/Piano%20stairs) accessed 2019-04-30
10. Source: <https://goodvertising.site/the-fun-theory/Slide> accessed 2019-04-30
11. Source: <http://www.mamut-pub.cz/>
12. Source: <http://www.mcqueenstavern.com.au/big-burger-challenge.html>
13. Source: <https://www.dailyedge.ie/biggest-pizza-pictures-2246307-Jul2015/>
14. Source: <https://www.dailymail.co.uk/news/article-2589184/Top-dog-Worlds-largest-hot-dog-weighs-whopping-125-5-pounds.html>
15. Source: <http://www.simply4friends.at/blog/index.php/photoblog/archiv/C20/P1300>

Communication

Communicating Author: jerzy.obojski@novismo.com

TRIZfest 2019

September 11-14, 2019. Heilbronn, Germany

PROCESS INNOVATION IN PACKAGING CHOCOLATE COOKIES

Michael Graf

Lauda-Unterbalbach, 97922, Germany

Paper Classification:

- Case study

Abstract

It is in the nature of mechanical interfaces between different machine suppliers that disturbances might occur even when detailed specifications of the interface parameters are directing the different manufacturers during the design phase of their machines. In addition to the equipment, also the variance of chocolate cookies recipe and chocolate quality are creating a challenge to the entire system not expected from the start of the project.

The cookie production and packaging from dough mixing to baking via cooling and packaging consist of 22 functions manufactured by 9 different suppliers with fully automated product transport and cookie handling. Production proved successful in the first months of full cookie production.

While changing the quality of the chocolate used in the dough, the design parameters were changed, the cookies no longer behaved like before, production was stopped, cookie waste was generated, and the individual suppliers were struggling with holistic solutions. Using the TRIZ toolbox (physical contradiction and ARIZ) as a vehicle to discuss the project on a pure technical base without emotions, it has been enabled to develop technical solutions and add a premium to the customers production e.g. energy efficiency recovery on heat and motions, cut down on change over time the machines and increasing of Overall Equipment Effectiveness (OEE).

Keywords: Process innovation, Problem identification, Problem solving, Concept Substantiation, thinking outside the box, Holistic TRIZ, OEE (Overall Equipment Effectiveness), ARIZ (The Algorithm for Inventive Problem Solving), Physical contradiction

1 Project

As an innovator in packaging technology and industrial electronics, the Schubert Group works with its customers and partners to shape the present and future in numerous industry segments. With its philosophy of modular, intelligent Top-loading packaging machines (TLMs), the family business from Crailsheim (Baden-Württemberg, Germany) has been breaking entirely unique technological ground. Since the company was established in 1966, Schubert has grown to be the internationally recognised market leader for digital packaging machines.

With the interaction of simple mechanics, intelligent control technology and high modularity, Schubert provides manufacturers of food, confectionary, beverages, pharmaceuticals, cosmetics and technical consumer goods automated packaging machine solutions which can be easily adapted to changing markets and trends in product format. [1]

With its subsidiary company, Schubert Packaging Systems, the Schubert Group combines machine design with extensive expertise in system design and in engineering.

Schubert Packaging Systems stands for comprehensive customer support and creative solutions, independent of suppliers, in the pharmaceutical, cosmetics, technical products, foodstuffs, confectionary, snacks, pet food and beverage sectors of industry. By taking on full responsibility as general contractor, we provide total support through every project phase during the planning and implementation of automated packaging solutions for our customer's products. Our extensive experience with different technologies and in various industry sectors allows us to think in interdisciplinary terms as well as the ability to transfer proven processes and techniques from other areas into new applications. [2]

As the head of Schubert-Consulting it is my intention to provide strategic thinking, holistic view to projects and their processes as well as to deliver consulting tools to the internal team and ensure that we serve our customers with a premium as add-on to their project.

Our general approach to the processes allowed us to define the machine interfaces more clearly and to describe the process from the beginning to the end in a way that circumstances on one machine could be handled on the downstream equipment and vice versa. This will be dealt with differently if only individual machine suppliers commission their equipment separately without a focus on the entire packaging line.

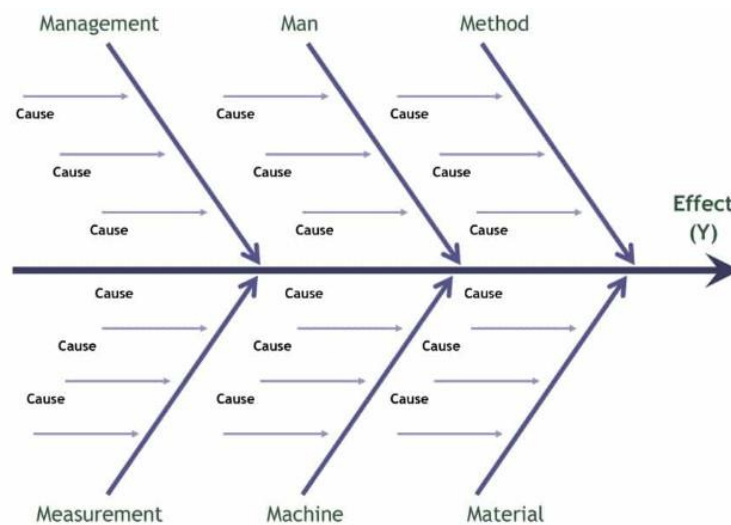


Fig. 1 Ishikawa – Fishbone Diagram

Only standards will be fulfilled and the customers' need will never be met. Interfaces are uncontrolled and unmonitored as they are not part of standard machineries. We follow Mr Ishikawa's method as a road map of holistic view on projects and establish TRIZ as innovative solution provider.

2 TRIZ relation

The OEE of an entire production line dropped down after the recipe parameters of the cookies were changed. Individual machine suppliers tried to solve the problem only for their own area of functionality and failed. Emotions between the 12 suppliers led to non-fruitful discussions towards a final goal. Schubert-Consulting has been pointed out to raise the output of the chocolate cookie plant. Using the network of the TRIZ, a mediator has been asked to join the task force after preparing the site and the suppliers to agree to a common workshop.

Keeping in mind the TRIZ philosophy (problem identification- problem solving- concept substantiation), a master plan was designed.

Phase 1 – Process analysis

Phase 2 – Process identification

Phase 3 – Process layout

Phase 4 – Supplier Workshop – generating of solutions

2.1 Phase 1 - Process analysis

Gathering data is a perfect start to get used to the process and to get familiar with the product typical behaviors.



Fig. 2 Process function definition

The chocolate cookie production was defined in 22 blocks. The individual functions were photographed and added to the observation list this to ensure that different people responsible for the observation in different areas and various timing were guided to enter the right data tracked.

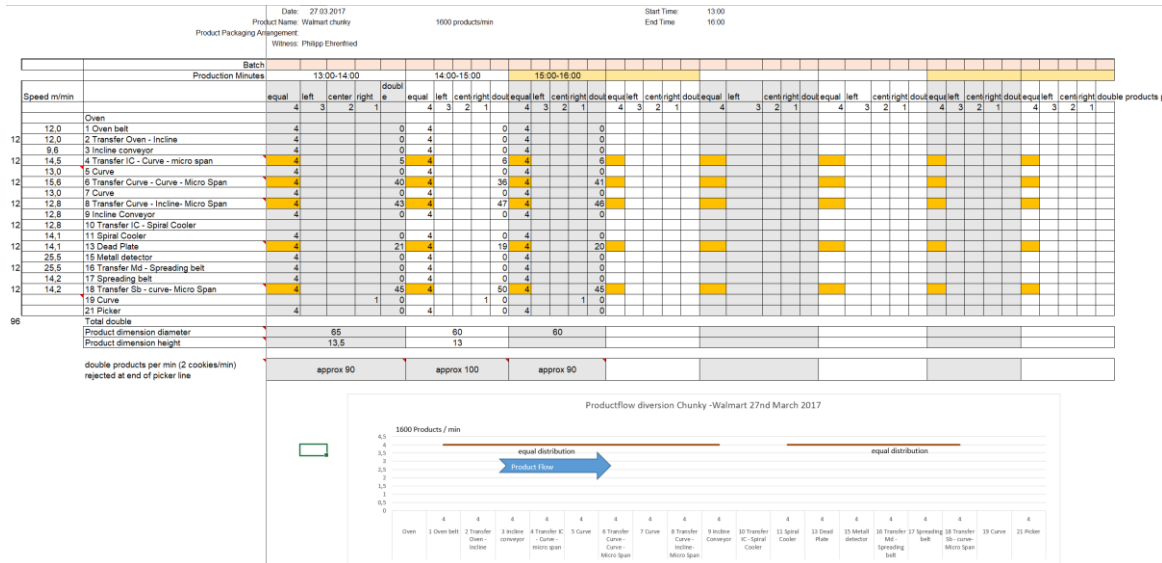


Fig. 3 Data monitoring and flow analysis

Arranging the data in timely manner and using different chocolate recipe and subsequently also different chocolate quality a large quantity of data evolve. Values and behaviors of the different unctions needed to be questioned and prepared. A flow analysis was sketched on a high level base.

2.2 Phase 2 - Process identification

Starting data mining of the gathered information from the line, the real products were arranged with the theoretical values taken from the line.

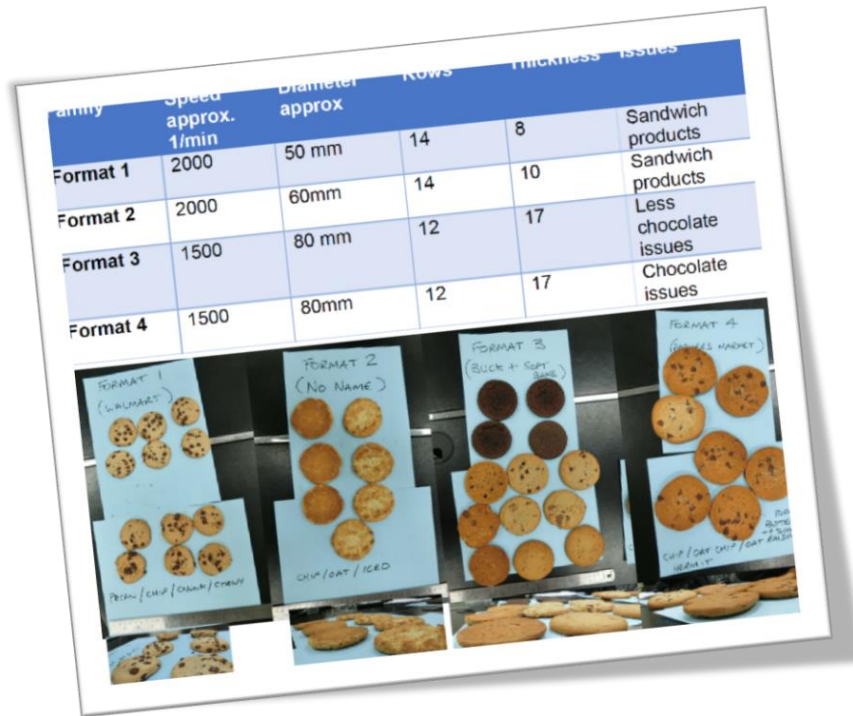


Figure 4 Merging cookies with theoretical values

The value taken from the exercise opened us the eyes “high quality chocolate takes longer to cool down to transport temperature than low quality chocolate”.

This results in liquid chocolate contamination from one single machine and equipment to the other. The contaminated transport section got subsequently a different habit in transporting of the chocolate cookies. Consequently, the chocolate cookies are no longer positioned as needed. The undefined orientation of the product results in malfunctions of the entire equipment and subsequently to undefined stops of the entire production line.

2.3 Phase 3 - Process layout

By transferring the function blocks to the layout and adding the high level information, a landscape of the process is prepared. Highlighting all problem areas set indications to relevant layout areas and machines. The proper prepared information set support the “cause effect chain analysis” for process.

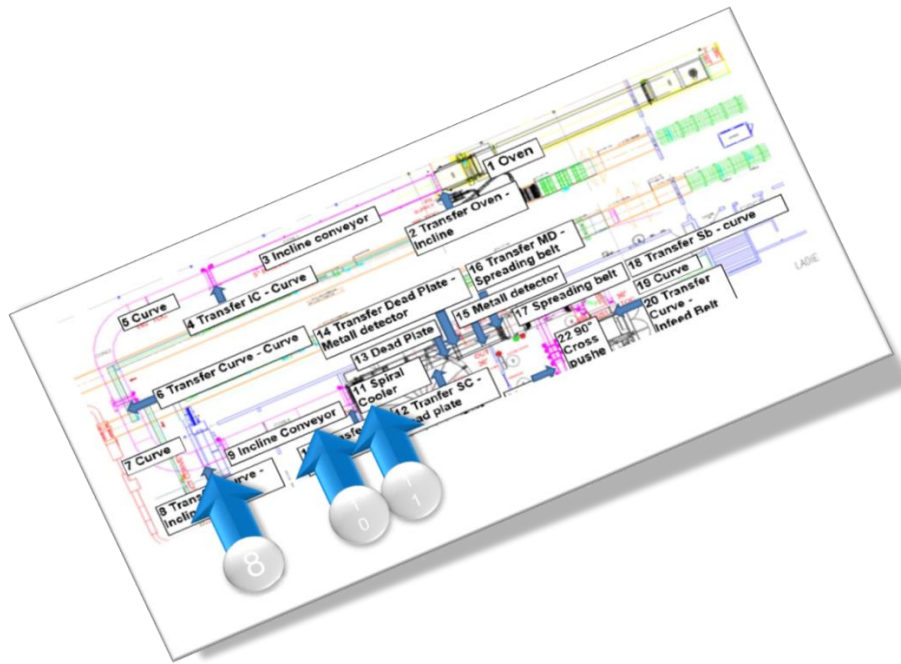


Figure 5 Landscape of machines and issues

Using the map, all suppliers are capable to follow up how issues on their machine could result in difficulties for other vendors.

2.4 Phase 4 - Supplier Workshop – generating of solutions

As to get rid of the emotions of vendors participating in the workshop, the layout was simplified to blocks of functions.

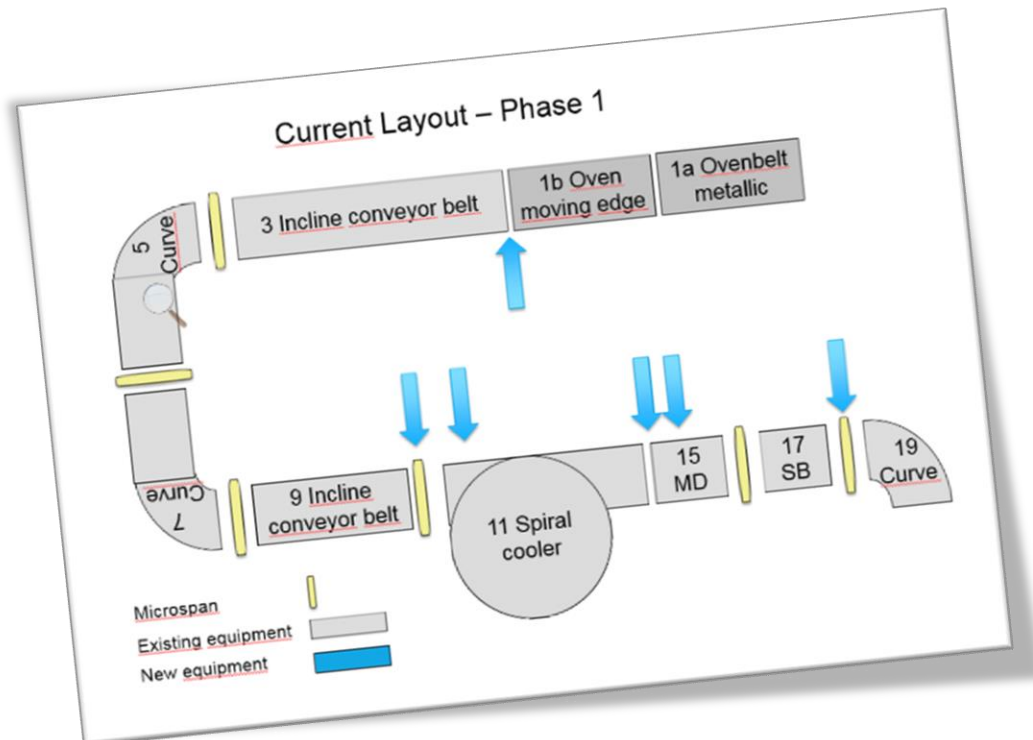


Fig. 6 Function block layout

Preparing the data in a way of plainness, preparing the meeting in a neutral environment and having a moderator at hand with the knowledge of all relevant “innovative problem-solving tools” the workshop was settled.

Seven out of twelve suppliers were committed to participate for an entire day. Discussing the results of the data evaluation, process evaluation and general layout, the participants got a better understanding of the general birds eye view to the issues.

After separating the problem apart from the individual supplier machine functions, the discussion input from the various experiences of the suppliers of equipment became very fruitful. Taken the thoughts away from the mechanical issue of the machine, a common understanding of the problem has been done by concentrating on the product and the task how the problem has been defined.

The problem description on a general level started and lead the discussions towards the physical contradiction:

The chocolate needs to **be warm** to get mixed in the dough
and
the chocolate needs to **be cold** to avoid sticking onto the conveyors.

Using several TRIZ tools and pointing out the areas where the chocolate needs to be warm and areas where the chocolate needs to be cold, there were plenty of solutions found for the single areas of conflicts. The following items are a pre-selection of the founded solutions:

- The discharge conveyor of the cookie baking oven will be used to cool down the cookies (“separation in time”)
- The interfaces between the transport conveyors will be reduced by lengthening the conveyors (“trimming”)
- The spiral cooler will get automatic speed control according to the diameter of the cookies (“feature transfer”)
- The spreading belt after the spiral cooler will be eliminated (“trimming”)

Further ideas were generated by using ARIZ and feasibility studies.

The final result of the workshop was an action log for the involved machine suppliers defining the action, resources, timing, cost and priority.

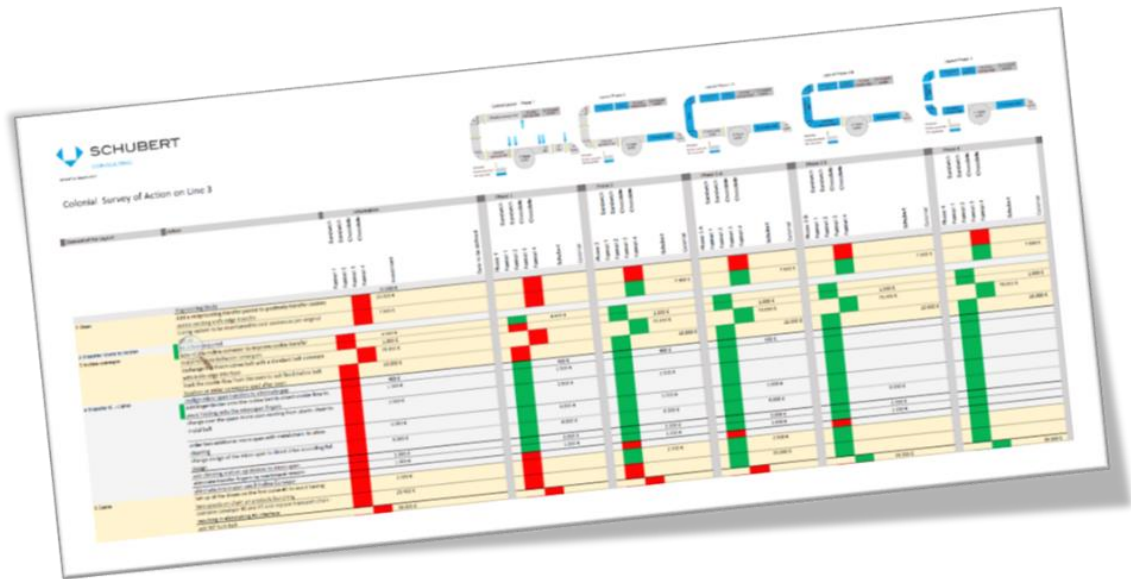


Fig. 7. Action log listing the follow up

The follow up defined three steps to proceed:

Step 1 – design the specific solutions

Step 2 – integration of solutions into the machines

Step 3 – production test and live runs



Fig. 8 Chocolate cookie

3 Results

3.1 TRIZ as tool to eliminate emotions

By the use of TRIZ as technical problem solving tool, the communication from machine supplier to machine supplier has been focused on the technical level. Finger pointing of problem initiator has been avoided by using the process flow and “cause effect chain analysis”. The major item and door opener to the problem was the founding of a trivial physical contradiction

that the chocolate needs to be cold at one time of production and the chocolate needs to warm at another time of production. Having found the common difficulty of the line it was easy with engineers to evaluate and find solutions for modifications.

3.2 Reducing development time

The machine suppliers were working on developing solutions for approximately 2 months on their own. First when the process of pure innovative problem solving started, all actions were designed, manufactured and taken in place in less than 3 months.

3.3 Energy saving

Using the recovery on the discharge belt of the cookie oven, real money has been saved for the production and the chocolate has been brought to the required temperature. This premium output additionally has nobody expected on the beginning of the project.

3.4 Faster change over time - Increase OEE

As the interfaces between transport units of the machine were reduced the change over settings for side rails were dropped by 50% of the time. The OEE increased and the output of cookies were improved for customers satisfaction.

3.5 Customer relation

As at the beginning of the project all participants were eager to work together, the project has led to a partnership over the last 2 years. Orders for other production lines were placed with the company.

4 Conclusions

The project success was based on the holistic view of the management team using TRIZ outside the standard procedures and traditional behaviors. In addition, TRIZ has also taken in mind that softfacts as well as hardfacts are important in finding innovative and sustained solutions. As TRIZ teach you bringing the problem to a higher level you only need to try to apply this also for management consulting activities, like demonstrated in this project. Since then, we take the idea of TRIZ and adopt wherever we can to boost us forward to success in the future in management.

References

1. <https://www.schubert.group/de/group/unternehmen.html> , 2019
2. <http://www.schubert-packaging-systems.de/en/company/schubert-packaging-systems/profile.html> , 2019

Communication

Communicating Author: m.graf@schubert-packaging-systems.com

TRIZfest 2019

September 11-14, 2019. Heilbronn, Germany

PHYSICAL CONTRADICTION RESOLVING BY SEPARATION OF CONTRADICTORY REQUIREMENTS IN SPACE OR TIME ON MICRO-LEVEL

Alex Lyubomirskiy

GEN TRIZ, LLC, Boston, 02072, USA

Paper Classification:

- Theoretical, research results

Abstract

In many cases, it is necessary to resolve physical contradictions by separating contradictory properties in space or time, even if both requirements belong to the same area or period. It is possible, using separation in space or time on micro-level. For this purpose, it is necessary to divide entire area or period to small segments and distribute opposite properties among them.

Keywords: *physical contradictions, separation, space, time, micro-level.*

1 Project

TRIZ was created to solve inventive problems. Therefore, within its framework, a number of problem solving tools were created - techniques for resolving Engineering and Physical Contradictions, Inventive Standards, ARIZ, databases of scientific effects, a database of Clone Problems, etc. Significant efforts were spent on their improvement, which naturally led to the rapid development of these tools. However, over the past 20 years, the focus has shifted to the area of analytical procedures preceding problem solving (Function Analysis, Flow Analysis, Cause-And Effect Chain Analysis, Trimming, etc.), as well as following them (for example, the Supereffect Analysis). Accordingly, in this area, there is a rapid growth, and the classic tools look quite stable in comparison with them.

However, the solution of inventive problems is the apogee of almost any innovative project. Indeed, one can very deeply analyze an Engineering System, but if formulated problems were not solved, achievement of the project goal is highly unlikely. Therefore, the development and improvement of problem-solving tools is still a very important goal.

One highly effective problem-solving method is an algorithm for resolving physical contradictions. There are three main ways to resolve the PC [1]:

- Separation of contradictory requirements
- Satisfying contradictory requirements
- Bypass

Within the Separation domain, the most powerful methods are separation in space and in time. Presumably, they are applicable only if contradictory requirements belong to different areas or periods. Otherwise, separation looks impossible.

Nevertheless, it would be useful to extend separation in space and in time, albeit with some modifications, to situations where contradictory requirements belong to the same area or period. This would increase the efficiency of inventive problem solving, which, of course, is always actual.

2 TRIZ Relation

Let us analyze few examples from different areas, and then formulate a hypothesis.

2.1 *Battery electrodes*

Physical contradiction:

The electrode has to consist of an active material, which is naturally non-conductive, to provide high capacity. However, it has to consist of conductive (and naturally passive) material like carbon to provide high conductivity.

Both contradictory requirements belong to the same area – the entire electrode. Therefore, separation of contradictory requirements in space looks impossible. Nevertheless, the solution of the problem is a compressed mixture of micro-granules of active material and carbon [2]. This means that the separation in space was made on the level of micro-granules: both materials occupy different volumes. On the macro-level, there is no separation in space because both materials occupy the same volume.

It is necessary to emphasize that in this case there is no separation of contradictory requirements on the system level. This would only be true if each part of the electrode was active yet non-conductive, and the entire electrode would be conductive yet passive, or vice versa. However, it is not true - the entire electrode has both properties, not one of them.

2.2 *Contact welding*

Physical contradiction:

Electric current should be strong to heat parts effectively, but it should also be weak when measured to inform the controller about the state of welding zone.

The contradictory requirements belong to the same period: the duration of the welding. However, the separation in time was still made: short impulses of weak measuring current are passed in the moments when the sinusoidal wave of strong current goes through zero [3]. On the level of impulses both currents act subsequently and on the level of entire welding process they work simultaneously.

We still cannot say that it was separation of contradictory requirements on system level. That would only be true if every impulse would be measuring (weak) while the entire current would be strong (heating), and vice versa. However, it is not true - the entire electric current passing through welding parts has both opposite properties, not only one of them.

2.3 Hypothesis

As we can see, in all examples the situation does not assume the separation of contradictory requirements in space or time because they belong to same area or period. However, separation is made by dividing the entire volume or period to small zones.

This means that *the separation of contradictory requirements in space or time was made, but on the micro-level*. To do this, it is necessary to divide the area or period to which both contradictory requirements belong into small segments and distribute opposite properties among them.

If this hypothesis is correct, it is necessary to determine what conditions this method of separation is going to be successful for. Therefore, one of the requirements is the absence of mutual compensation or the summation of both properties- for example if due to some reasons we need a glowing object to be bright and dim in the same time. If we would try to assemble it from bright and dim pieces, on the macro-level it will just have some average brightness due to the summation of both light flows. However, if we would need to make it glow blue and red simultaneously, combining of blue and red pieces would work- each piece would be exclusively blue or red, but entire object would emit both frequencies. Alternatively, we could make it quickly switch between blue and red to get both.

A good representation of the described method of separation in space is various mixtures such as solutions, emulsions, and suspensions. The separation in time on the micro-level could be illustrated with various variants of performing one action in pauses of another one, fast switching between opposite states, etc.

Transition to micro-level is known in TRIZ – it is part of the Trend of Transition to Supersystem. This fact does not compromise novelty of suggested approach or make it unnecessary. For example, another well-known and highly effective method of physical contradiction resolving – separation on system level – coexists with this trend without any problems. Moreover, it is a good sign, because all our problem-solving methods are based on evolutionary trends and thus they should somehow reflect them.

Here are two more examples:

2.4 Fuel ignition system for aircraft turbine

The ignition system for an aircraft turbine applies a laser beam to ignite the fuel aerosol. Fuel droplets focus the laser beam in a very small volume. The highly focused laser beam ionizes air, creating a small cloud of hot plasma. This plasma ignites other fuel droplets [4].

Physical contradiction:

Fuel droplets in the combustion chamber need to be large to focus the laser beam effectively, but they should be small enough to be easily ignitable.

Like in the previous example, contradictory requirements belong to the same area: the aerosol in the combustion chamber. Therefore, an attempt to separate contradictory requirements in space looks unreasonable. Nevertheless, the solution of the problem is a mixture of droplets of different diameter- 10% of the mixture are large droplets that focus the laser beam while 90% small droplets ignite easily. It means that separation in space was made on the level of individual droplets: each droplet is large or small. On the macro-level, there is no separation in space, because in the entire ignition chamber droplets are large and small in the same time.

2.5 *Biological example: cricket *Gryllus rubens* and parasitic fly *Ormia ochracea**

Natural systems also meet physical contradictions and often resolve them with similar methods.

For example, *Gryllus rubens* crickets attract females by loud singing during mating periods. They have the dangerous enemy – the parasitic fly *Ormia ochracea* that lays eggs directly into the cricket's body. In the process of evolution, these flies learned how to use the mating songs of crickets to locate their prey [2].

Physical contradiction:

Crickets must sing loudly to attract females, but they need to keep silent to not attract flies.

Contradictory requirements belong to the entire local population of cricket males; therefore, according to existing rules, they cannot be separated in space. Nature found a solution on the micro-level- 10% of “macho” crickets sing loudly while the others sit silently, intercepting arriving females. This means that the separation of contradictory requirements in space is made on the level of individual crickets- each cricket sings or keeps silent. However, the entire local population sings and keeps silent in the same time.

3 Results

As a result of this development, a new approach was identified for resolving physical contradictions by allowing the separation contradictory requirements in space and time, even when both requirements belong to the same area or period accordingly.

In addition, a criterion for successful separation was formulated- the absence of mutual neutralization or the summation of opposite properties.

4 Conclusions

4.1 *Conclusions*

- A developed method of resolving physical contradictions by separation contradictory requirements on space or time on the micro-level exists
- This method does not boil down to known methods, and can be successfully applied for solving inventive problems
- Therefore, it makes sense to include this method into the Algorithm of physical contradiction resolving, marking it as “experimental”. This will allow us to intensively test it on practical problems, collect application statistics, and later make an educated decision regarding whether it should be included into the standard methodology

4.2 *Next steps*

It will be necessary to:

- Collect and analyze more examples that illustrate the identified method of resolving PC
- Solve more practical problems using this method
- Potentially identify a subset of Inventive Principles that could be effectively used with this method
- Potentially identify additional criteria that allows or prohibits the application of this method

References

1. Altshuller G.S. Algorithm for inventive problem solving ARIZ-85B. – Yekaterinburg: Middle-Ural Publishing house, 1992. P. 199-212
2. David Linden, Thomas B. Reddy (ed). Handbook Of Batteries 3rd Edition. McGraw-Hill, New York, 2002
3. <https://www.sciencedirect.com/topics/materials-science/spot-welding>
4. <https://www.sciencedirect.com/science/article/pii/S2212540X16000055>
5. <https://www.sciencedaily.com/releases/2006/12/061213123726.htm>

Communication

Communicating Author: alyubomirskiy@GEN-TRIZ.com

TRIZfest 2019

September 11-14, 2019. Heilbronn, Germany

STIFFNESS IMPROVEMENT OF FLEXIBLE ARM BASED ON TRIZ THEORY

Siqing Chen, He Xu*, Haihang Wang, Yonghui Zhang, Peng Li, Vishwanath Pooneth

*College of Mechanical and Electrical Engineering, Harbin Engineering University,
Harbin, 150001, China*

Paper Classification:

- Case study

Abstract

Due to their high adaptability and minimally invasive features, flexible robots are used in various fields. The field dependent requirements are easily met if the actuation of the flexible robots is designed with soft materials. Yet, in certain situations, these materials fail to give the flexible robot its required stiffness. To better understand and propose an ideal solution, this research experimented a flexible arm resembling muscle. Upon analysis using the S-Curve analysis and the Functional Analysis, an appropriate SAFC model was established. Based on the TRIZ principle, a magnetorheological fluid was found by the contradiction analysis to solve the problem of low stiffness and the relationship between the fluid and the flexible arm was obtained. Finally, through evaluation, the flexible arm's new structure fully met with the design requirements.

Keywords: *TRIZ, flexible arm, stiffness, Functional Analysis for Processes*

1 Introduction

Humans are already being replaced by advanced working robots. Compared with rigid robots, flexible robots have soft and extensible bodies enforcing their abilities to absorb shock and vibration, hence reducing the impact of probable collisions. Similarly, cases including high temperature or high pressure display greater adaptability with flexible actuators as compared to rigid ones. Because of these features, flexible robots are applied in industries, such as marine exploration, food processing, and medical treatment. Likewise, flexible robots have evolved to various categories including the muscle type, the wave tube type, and the type of soft materials actuation, respectively [1]. However, both marine exploration and medical treatment require the robot body to maintain a certain stiffness. Due to the soft material used in the flexible robots, most of their actuators exposed to changing temperatures or pressures, help to improve their stiffness and their expansion and bending abilities. Conversely, the stiffness of the flexible robot does not meet reach the requirements in some cases [2,7].

Theory of Inventive Problem Solving (TRIZ) has revealed the inherent laws and principles of creation and invention, focusing on clarifying and emphasizing the existence of contradictions in the system [3]. The goal is to be able to solve the contradictions completely and obtain the final ideal solution. It is also based on the evolution of technology and with more than 30000 patents information to study the entire design process, designers can use the knowledge and experience in different fields to solve problems more efficiently. Experiments proved that the application of TRIZ theory can accelerate the process of creation and invention greatly by delivering high-quality innovative products [4].

The following paragraphs describe the whole TRIZ workflow, from the process of the problem parse with S-curve analysis, component analysis, and function analysis to the problem-solving with contradiction. Figure 1 is the flow chart of TRIZ detailing the TRIZ analysis, problem solving, and evaluation steps.

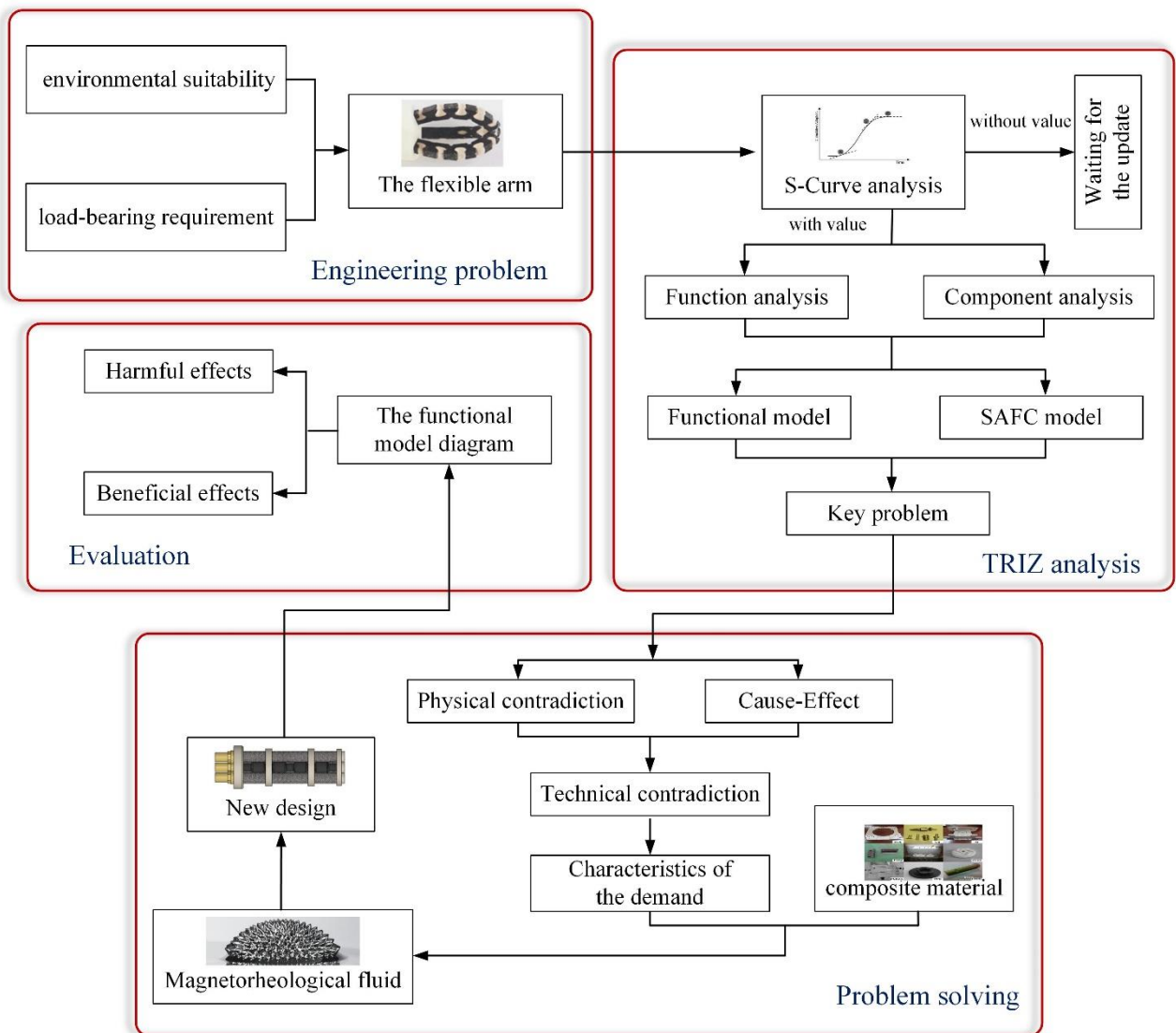


Fig. 1. The Flow Chart of TRIZ

2 Analysis of the Flexible Robot System

2.1 S-Curve Analysis and Assessment of Maturity Level

S-Curve is one of the development rules of many artificial and natural systems in the world. As Figure 2 shows, for the flexible robot, its technology has passed the transition period and began to approach its growth period. This shows that human society has realized the value and potential of flexible robots and resources are being invested in systems' development.

The Main Parameters of Values (MPVs) for an ideal flexible arm are defined as follows:

- Reasonable responding speed
- Reasonable stiffness
- High positioning accuracy
- High degree of freedom
- High adaptability to the environment
- Low exclusion of the human body
- Ability to absorb vibration and shock

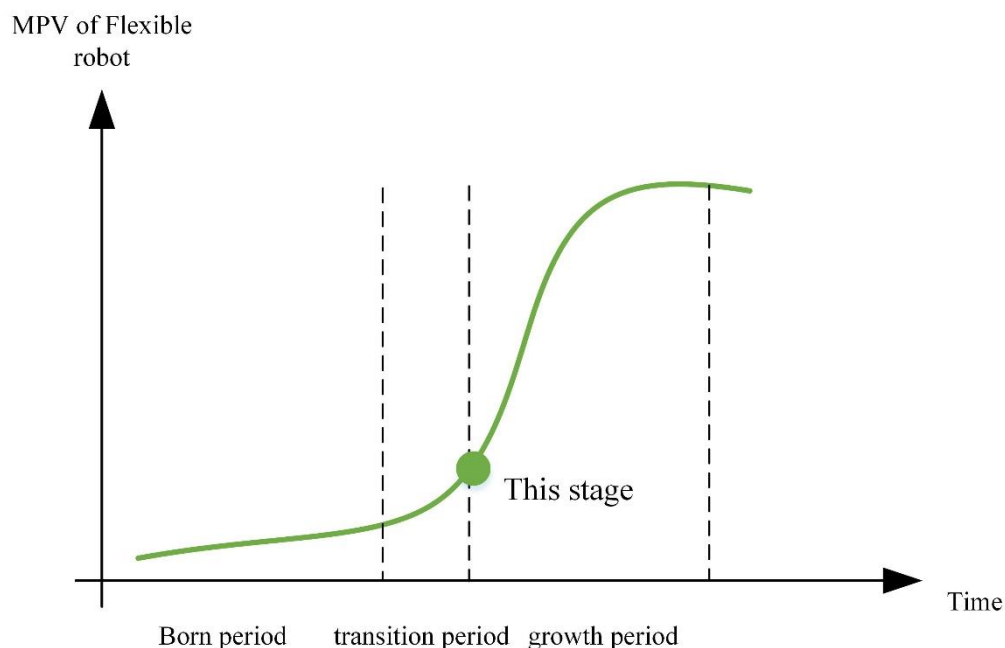


Fig. 2. S-Curve Analysis of the Flexible Robot

Even though, flexible robots have recently entered the market with their added novel features and excellent performance, there is still room for improvement. While most of the possible improvements of flexible robots are still under research and experiment, only a small part of the technologies has been applied to the actual production. Hence, to contribute to the current worldwide research, this study focuses on how improve the low stiffness value of an original flexible robot to a reasonable one. [2,8,9]

2.2 Component Analysis and Function Analysis

This research is based on the improvement of an original flexible arm's muscle in the market. As shown in Figure 3, the main body of the flexible arm contains sealing elements, artificial muscles, and retainers. Figure 4 shows that the artificial muscle is an actuator of the flexible arm, which consists of sealing elements, woven mesh tubes, and rubber tubes. Rubber tubes are made up of an elastic material, with both radial and axial expansion in situations of increasing pressure. The pattern of woven mesh tubes is x-shaped and also the axial length and the diameter have an inverse relation (when the axial length increases, the diameter decreases and vice versa).

As shown in Figure 2, with an increasing pressure, the rubber tube expands both radially and axially. Due to the end of woven mesh tubes being immobilized by pipe clamps, the rubber tube makes the artificial muscle shorter to drive the flexible arm. It is controlled by a pressurized pipe, which elongates with increasing pressure.

Most flexible arms are loaded and adapted to complex environments by artificial muscles' deformation. Complex environments include narrow spaces, complex curved spaces, underwater spaces, and the spaces of creature in vivo. Although the soft muscles of the flexible arms adapt well to these conditions, their effects on the stiffness do remain small. In addition, the load is one of the important conditions for stiffness of the flexibility arm.

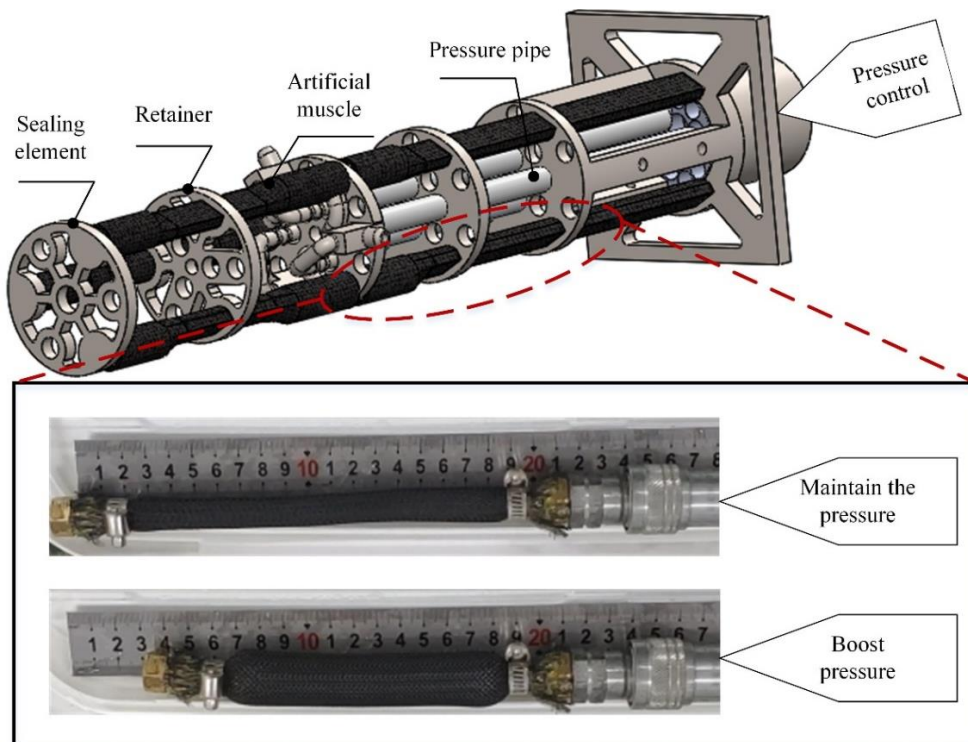


Fig. 3. Component of the Flexible Robot

According to the component analysis and existing literature, artificial muscles stiffness increase with rising pressure. For the convenience of research, artificial muscles are regarded as one component. Similarly, as per the engineering description, the flexible robot was selected to be the engineering system to be researched in the TRIZ project. [1,8] Table 1 shows the component

analysis results of an engineering system of the flexible robot. The system components and super system components of the flexible robots are identified by component analysis.

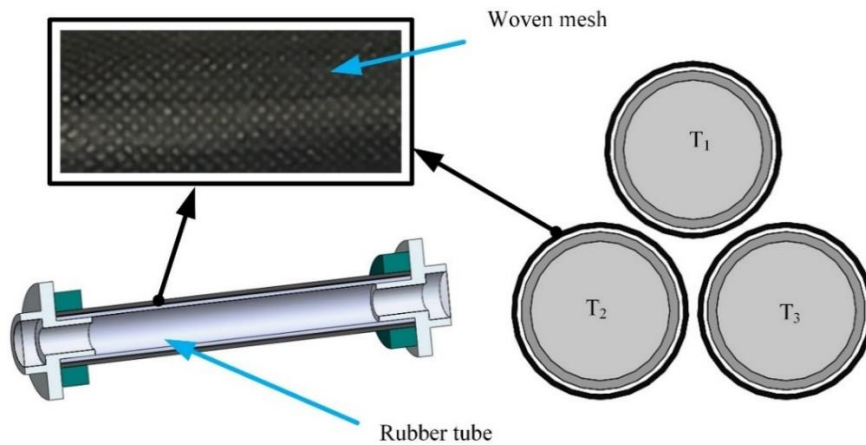


Fig. 4. Sectional View of Artificial Muscle

Functional analysis was performed according to the interaction matrix and the interaction analysis was used to identify the interaction between the components of the flexible robot and to lay a foundation for the establishment of the functional model. [8,9] Table 2 below shows the interaction analysis results of each component.

Table 1

The Component Analysis Results

Engineering system	System component	Supersystem component
Flexible robot	Artificial muscle	Complex environment
	Sealing elements	Work load
	Retainer	
	Pipe clamp	
	Pressure pipe	

Table 2

The Interaction Analysis Results of Each Component

Component	Artificial muscle	Sealing elements	Retainer	Pipe clamp	Pressure pipe	Work load
Artificial muscle		+	+	+	+	+
Sealing elements	+		-	+	+	+
Retainer	+	-		-	-	+
Pipe clamp	+	+	-		+	-

Pressure pipe	+	+	-	+	-
Work load	+	+	+	-	-

2.3 Model Analysis

Figure 5 shows the simplified model of the flexible robot and its presentation of motion. Generally, flexible arms work in complex environments, such as underwater, narrow space, and peoples' body. This flexible arm is composed of three artificial muscles rotated 120° about the longitudinal axis of the arm. At the end of the flexible arm, the artificial muscles are sealed and immobilized with a rigid sealing element. When one of the artificial muscles (T3) is pressurized and the other two artificial muscles (T1, T2) maintain pressure, and the sealing element forms a triangular position with the base and tilting towards the pressurized artificial muscle. Due to the elasticity of the soft materials in the flexible robot, artificial muscles become crook to adapt the tilt of the sealing element. Because the stiffness of the low-pressure muscle is lower than that of the high-pressure muscle, the degree of bending of the high-pressure muscle is smaller than that of the low-pressure muscle, which makes the flexible arm bend towards the pressure pipe. The flexible arm is connected to the rigid base plate and is used to interfere with the rigid parts.



Fig. 5. Simplified Model of the Flexible Robot and Its Presentation of Motion

According to the driving principle of the flexible arm, the functional model diagram and SAFC model diagram of flexible arm are shown in Figure 6 and Figure 7, respectively.

Through the model analysis, all the components in the flexible robot are analyzed in detail. The functions of the components are identified and classified, and it is found that the function of the components in the flexible robot is insufficient: the retainer cannot provide sufficient stiffness for the constant artificial muscles and the load - bearing and anti - torque of the flexible arm are mainly concentrated.

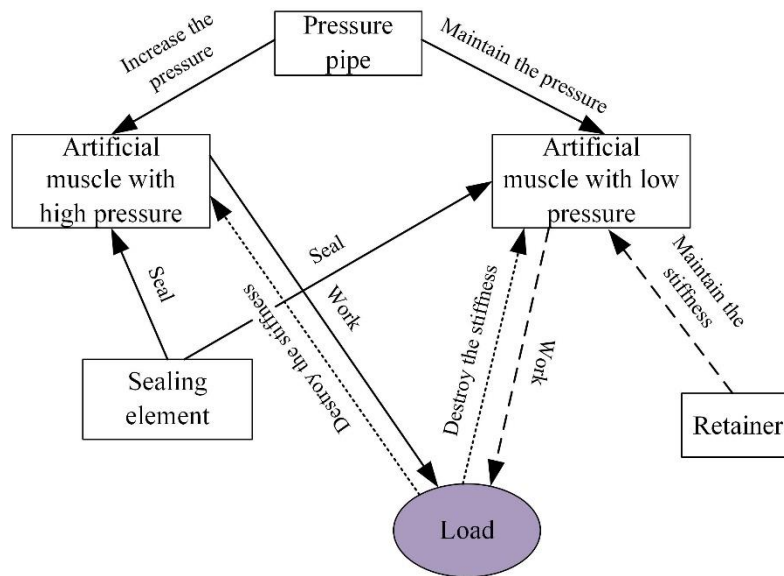


Fig. 6. The Functional Model Diagram of the Flexible Robot; solid line = useful function, dashed line = useful but insufficient function, Dense dashed lines = harmful function

3 Problem Solving

3.1 Contradiction Analysis

For this flexible arm, the key problem is that the stiffness of artificial muscle under constant pressure is not enough. The SAFC model shows the Causal - Effect Chain of this problem, which is caused by the soft material of the flexible arm and the lack of functionality of the retainers.

One of the solutions is to enhance the function of the retainer so that it can give the artificial muscle higher stiffness. However, there is no new approach to improve the retainer and increasing the number of retainers will reduce the sensitivity and motion range of the flexible arm. Therefore, the scheme is invalid. Because the retainer is not the key concern of this article, it is simply described here.

A contradiction was also raised about the technology and performance:

In order to have high flexibility and high adaptability, the mechanical arm chooses to make by soft materials.

HOWEVER

Because the stiffness of soft materials is too small, they cannot be adapted to work better.

For the convenience of illustration, the characteristics of the existing flexible arm, such as high adaptability, high flexibility, are named "THE FEATURES" in this paper. As shown in Figure 7, its technical contradiction is that the properties (+) of soft materials can make the flexible arm obtain THE FEATURES, but the stiffness of the arm decreases due to the properties (-) of soft materials. Its physical contradiction is that the components of the arm must satisfy the properties of flexibility and high stiffness together. [1,9,10]

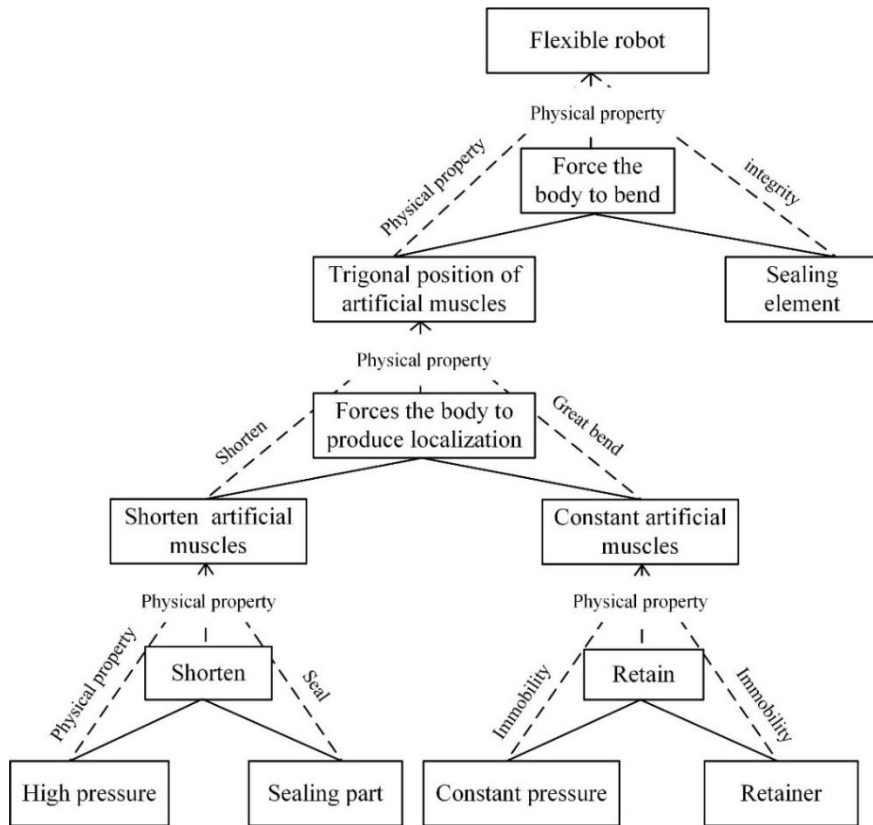


Fig. 7. The SAFC Model Diagram of the Flexible Robot

In figure 8, technical contradiction is transformed into physical contradiction. The current problem is to solve the problem of high flexibility and high stiffness in components of the mechanical arm. In this paper, functions of materials were separated. When the arm was loaded, it required to have a higher stiffness, but the arm moved, it needed to have higher flexibility. Therefore, the problem turned to how to find materials with different characteristics in different periods. It is became easy to consider with the conflict resolution of composite material.[1,10]

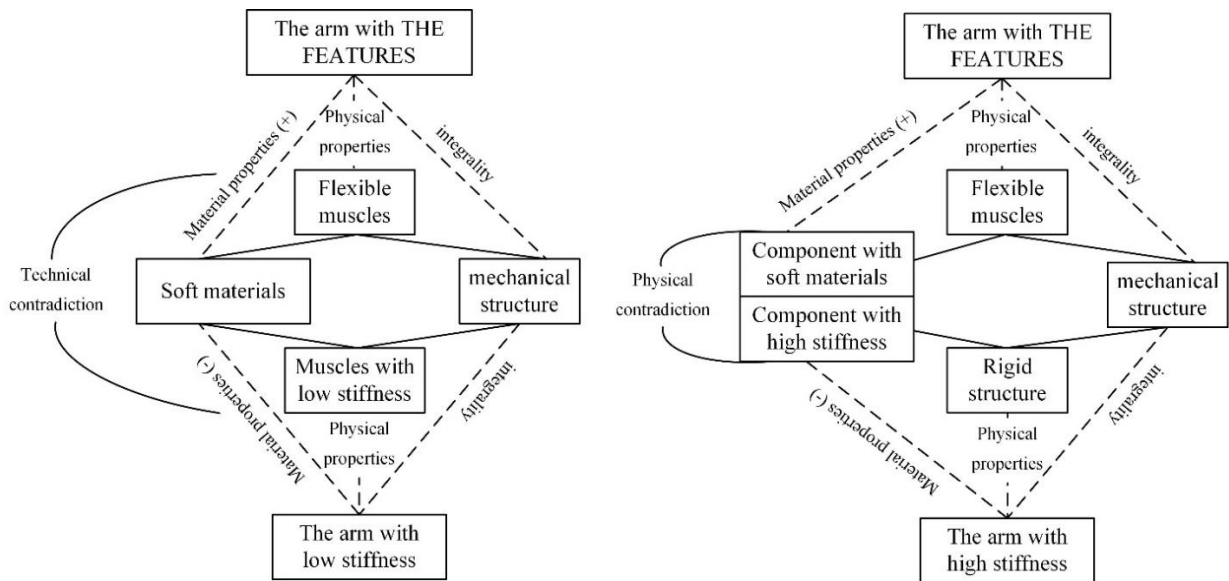


Fig. 8. The SAFC Model Diagram to Represent Technical and Physical Contradictions

3.2 Description of Magnetorheological Fluid

In the material database, a composite material with required properties, i.e., magnetorheological fluid, was found. A magnetorheological fluid (MRF) is a suspension formed by dispersing micron-sized magnetic particles in basic liquid or water. Figure 9 shows that, when there is no external magnetic field, the magnetorheological fluid has great fluidity. However, under the action of strong magnetic field, magnetorheological fluid can be transformed into Bingham fluid with high viscosity and low fluidity within milliseconds, and its apparent viscosity can increase by more than two ranks of magnitude, showing mechanical properties similar to solids' [5].

Under the action of strong magnetism, the magnetorheological fluid changed from Newtonian fluid to Bingham fluid, and its bending strength and torsional strength were improved under certain stresses. When the internal stress increases and exceeds a certain value, the magnetorheological fluid presents the properties of liquid and return to the Newtonian fluid state, which is regarded as the overload protection state [6].

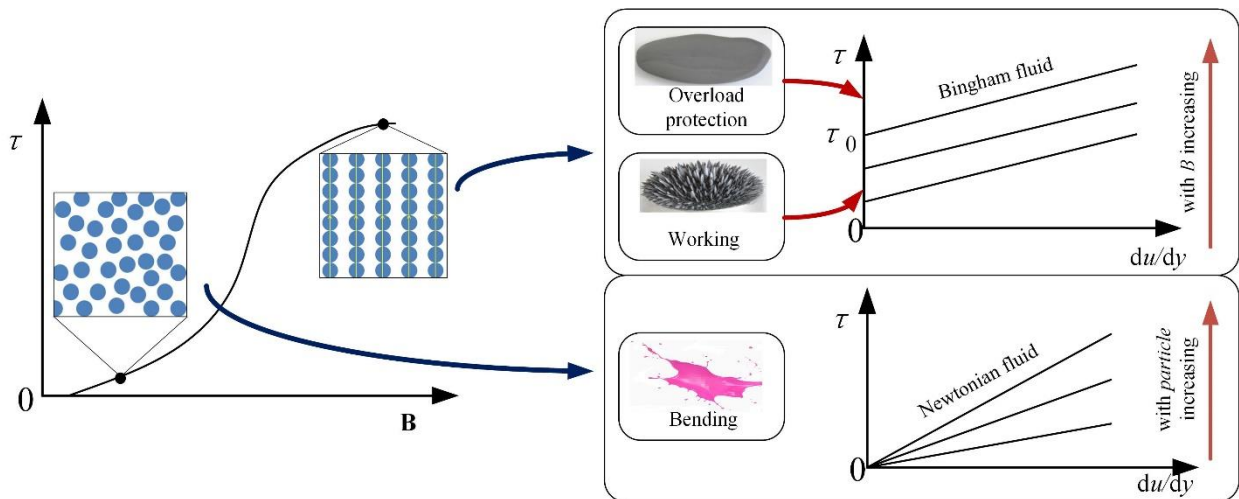


Fig. 9. Property Curve of the Magnetorheological Fluid

3.3 Applications of Magnetorheological Fluid

According to the analysis of contradictions and the properties of the magnetorheological fluid, a new type of flexible arm was designed. As shown in Figure 10, a new rubber wave tube forming a gristle structure was sealed at both ends with coil existing around the minor diameter. It was used to store the magnetorheological fluid. Moreover, when the flexible arm moved, the coil was not energized, and the magnetorheological fluid inside gristle structure showed liquid properties. Therefore, the flexible arm could move adaptably. When the arm was bent, the major diameter of the wave tube was also bent and the minor diameter remained to ensure that the coil did not deformed.

As well, the magnetorheological fluid inside major diameter moved away with the deformation to adapt. A magnetic field was generated inside gristle structure.. At this time, multiple high-stiffness cavities formed by the wave tube improved the shear strength and torsional strength of the cartilage structure to help the low-pressure artificial muscle support the load and increase

the stiffness of the flexible arm. When the load exceeded the rated value, the magnetorheological fluid will performed liquid properties. Besides, the flexible arm was protected from overload.

As shown in figure 11, the gristle structure is located in the middle of three artificial muscle circles. Therefore, no matter how the flexible arm is bent, the cartilage structure can provide stiffness for any low-pressure artificial muscle without affecting the bending of the artificial muscle. The bending degree of the gristle structure and the influence on the coil are minimized.

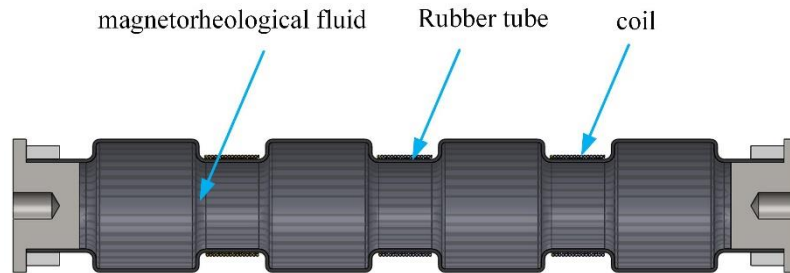


Fig. 10. Modelling of Gristle

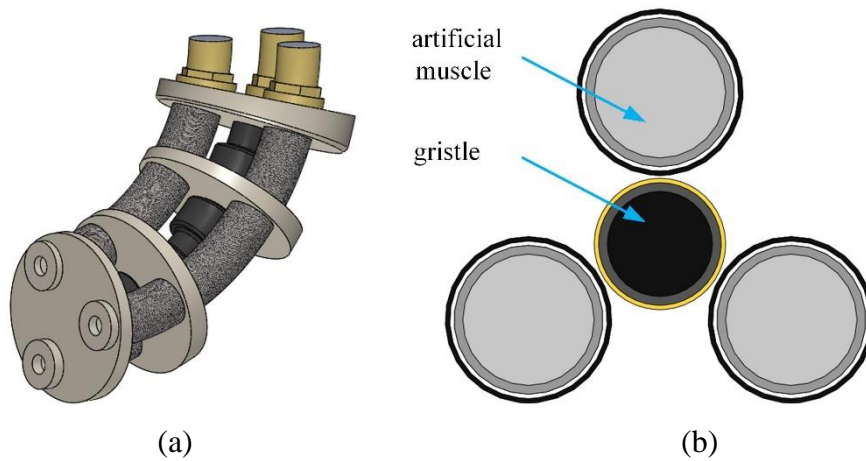


Fig. 11. Layout of Tubes; (a) simplified model of the new flexible robot, (b) the axial profile

3.4 Evaluation of the Design

The Figure 12 shows that the functional model diagram of the new structure that evaluates the previous design to check the both beneficial and harmful effects in the flexible arm. The new structure did not introduce new harmful effects into the flexible arm, but did add beneficial effects to improve the stiffness of artificial muscle.[9,10] This shows that the design met with the expected requirements.

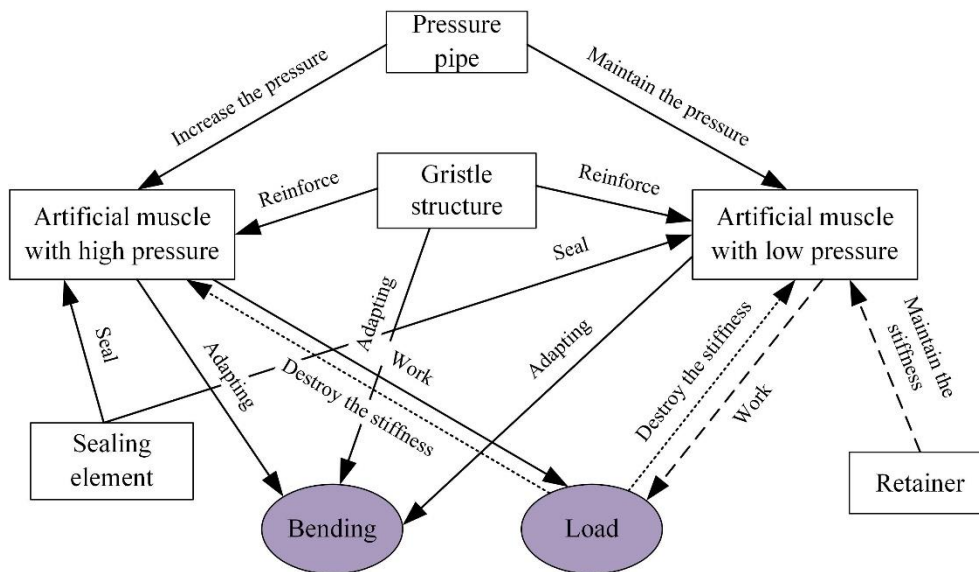


Fig. 12. The Functional Model Diagram of New Design; solid line = useful function, dashed line = useful but insufficient function, Dense dashed lines = harmful function

4 Conclusions

Based on the muscle-type flexible arm, the stiffness improvement scheme is proposed in this paper. Based on TRIZ theory, the S-curve analysis, the component analysis, and the function analysis of the flexible arm were carried out, along with establishing both the functional model and SAFC model. According to the model, the key problem of low stiffness of flexible arm was found, and the contradiction of solving the problem was put forward. Through the SAFC model, physical contradictions were transformed into technical contradictions. The research focus focused on composite materials: a magnetorheological fluid was used to improve the stiffness of flexible arm. The functional model diagram of the improved structure was analyzed, and it was found that the proposed design validated the design requirements, which provides a theoretical basis for future flexible arm design.

Acknowledgements

This work was supported by the Natural Science Foundation of China under Grant 51875113, Natural Science Foundation of the Heilongjiang Province of China under Grant F2016003, "Jinshan Talent" Zhenjiang Manufacture 2025 Leading Talent Project, "Jiangyan Planning" Project in Yangzhong City. This paper is funded by the International Exchange Program of Harbin Engineering University for Innovation-oriented Talents Cultivation.

References

1. Guido Kudielka, Tiziana Bertocelli "application of TRIZ methods for alternatives on cardiac activity detection in magnetic resonance imaging". TRIZfest, 2018.
2. Tsugami, Y., T. Barbie, K. "Development of Universal Parallel Gripper Using Reformed Magnetorheological Fluid". 11th Asian Control Conference, 2017.
3. Zhang, Hongying, A. Senthil Kumar "Topology Optimized Multimaterial Soft Fingers for Applications on Grippers, Rehabilitation and Artificial Hands". 2018.

4. Zhang X. Z., Gong X. L. "Study on the Mechanism of the Squeeze-Strengthen Effect in Magnetorheological Fluids". *Journal of Applied Physics*, 2004, 96(4):2359.
5. Wang C. N., Chen H. P., Hsueh M. H. "The Application of Knowledge Management and Triz for Solving the Safe Shutdown Capability of Fire Alarms in Nuclear Power Plants". *Kerntechnik*, 2017, 34(11):1045-1060.
6. Zhao Penghui, Yizheng Fu, Hai-long Li "Three-Dimensional Simulation Study on the Aggregation Behavior and Shear Properties of Magnetorheological Fluid". *Chemical Physics Letters*, 2019, 84(11):1273-1302.
7. Tsugami Y, Barbie T, Tadakuma K, "Development of Universal Parallel Gripper Using Reformed Magnetorheological Fluid". 2017 11th Asian Control Conference (Ascc), 2017: 778-783.
8. Xin Chui, Binjie Chang, Yongwei Sun, "TRIZ case: the TRIZ method is used to solve the problem of reducing the scale of fly ash in aluminum extraction process". *TRIZ Review*, 2019: 17-1.
9. Yongwei Sun, "TRIZ: the golden key to innovation (I)". Science Press, 2015-11-11.
10. Semyon Savransky, "Engineering of Creativity". CRC, 2000-08-29.

Communication

Corresponding Author: He XU, railway_dragon@sohu.com

TRIZfest 2019

September 11-14, 2019. Heilbronn, Germany

STUDY ON EROSION RESISTANCE OF CONTROL VALVE CAGE BASED ON TRIZ AND BIONICS

Min Cheng, He Xu, Feng Sun, Liye Jiao, Fengshu Yu

*College of Mechanical and Electrical Engineering, Harbin Engineering University,
Harbin, 150001, China*

Paper Classification:

- Case study

Abstract

Erosion is an important destructive phenomenon in water hydraulic control valve, and its high-speed sand-contained fluid has a severe erosion effect on the sleeve of the regulating valve. From the point of view of changing the shape and layered structure of the surface of the valve cage, the innovative method of combining TRIZ theory and bionics were used to improve the anti-erosion ability of the valve cage. Firstly, the crucial causes of the erosion in the valve cage were found by causal chain, and the erosion problem was decomposed. Secondly, the fundamental problems were analysed, and the solutions of different parts of the problem were combined to obtain the whole solution by using the tools of innovation, object-field model and bionics, and the solution of each part come from different biological source. Because the surface morphology of scorpion's back and the sandwich structure of tortoise shell can resist erosion, a multi-biologically coupled model of imitation scorpion and tortoise shell was established. The coupled biological model was mapped to the bionic physical model and the structure of the valve cage was improved. Finally, through the analysis of the CFD simulation, the effectiveness of the bionic structure was verified. The novel bionic valve cage showed a good performance on reducing the erosion of the valve.

Keywords: *Valve cage, Erosion resistance, TRIZ, bionic*

1 Introduction

As an important control element of the piping system, the regulating valve is widely used in various fields of industrial production. By changing the flow area to control the flow and pressure of the working medium, its working reliability is of great significance to ensure safe production and improve economic efficiency. In high temperature and high-pressure working environment, metal materials and water vapour will produce oxidation reaction. A certain thickness of oxidized skin is formed on the inner wall of the pipe, and it falls off to form solid particles. The solid particles move downstream with the fluid, which produces obvious erosion and wear phenomenon at the throttle of the regulating valve. The usual way to reduce erosion wear is to improve the abrasion resistance of the wall material, such as the use of wear-resistant materials, plating of wear-resistant materials on the wall surface or modification of the wall surface. These methods often lead to increased costs[1]. In this paper, the erosion site of throttle

valve was studied. Using the two innovative methods of TRIZ theory and bionics, the improvement scheme of the surface structure of the valve cage was found to improve the anti-erosion ability of the valve cage.

TRIZ and bionics are two innovative approaches in the fields of engineering and natural sciences that play important roles in solving problems. TRIZ is a powerful invention solution theory based on the research and summary of millions of patents. It is a high-level summary of practical experience[2]. Bionics came from natural sources, drawing inspiration for innovation from billions of years of evolution. Research the special structures of organisms and their structures are naturally reasonable. It is feasible and practical to apply the biomimetic mechanism and solve the product design problem with the TRIZ innovation principle. Therefore, the combination of bionics and TRIZ is not only conducive to the expansion of TRIZ applications, but also has important practical significance for expanding the application of bionics technology in engineering[3].

2 Combination of TRIZ and Bionic

When encountering engineering problems, you can combine TRIZ theory with bionics and complement each other to solve problems. The research methods of combining TRIZ and bionics is as follows: Firstly, the engineering technical problems transformed into the standard problems of TRIZ problems. The causal chain is used to analyze the fundamental problem of all problems. Then the object-field model and the innovation principles are used to describe the problem, find the ideal solution of the TRIZ problem. It can also clarify the direction and location of the problem, identify the resources that can be utilized, and serves as a bridge between engineering and technical issues with biological models for bionics methods. Then, according to the research path of bionics, the relevant structure (the actual solution of the engineering problem) was finally designed. As shown in Figure 1.

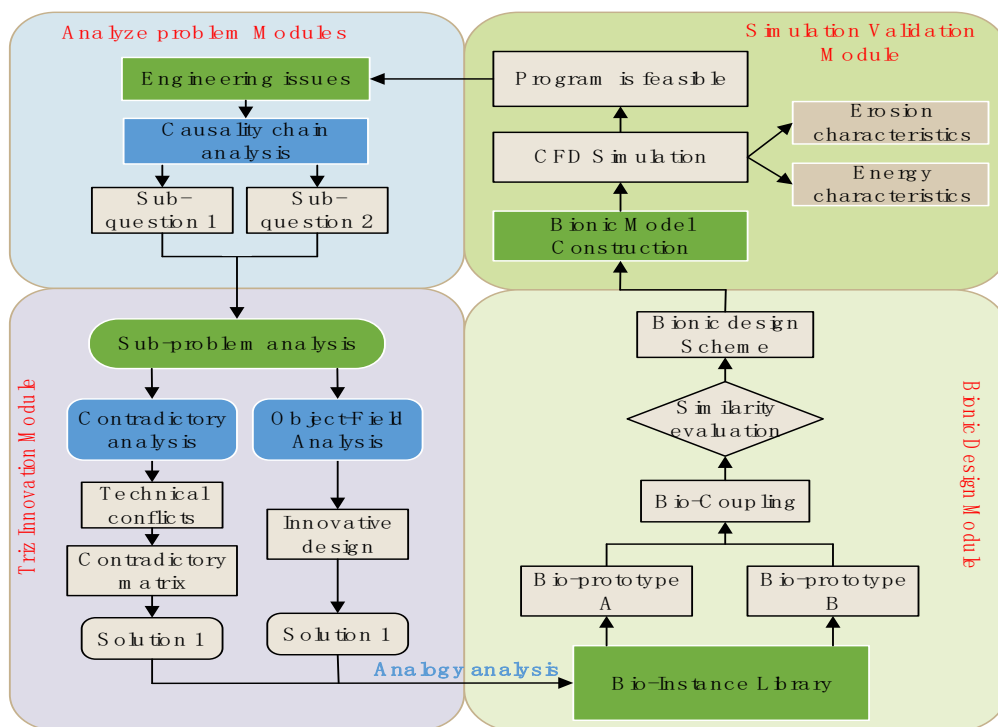


Fig. 1 TRIZ theory combined with bionic

3 Cause and Effect Chains Analysis (CECA) of the System

In many industrial applications, erosion wear has become one of the main causes of material damage. China's rivers have high sediment content and are one of the countries with high sandy water. Most of the regulating valves work in the drowning state. When the sandy water flows through the regulating valve, the erosion of the sand particles causes the surface of the cage to be uneven and finally fails.

Erosion wear and tear on the cage are mainly divided into two aspects. On the one hand, the surface material loss is caused by the cutting of abrasive particles. On the other hand, the crack generated by the normal impact of the abrasive grains on the surface of the material, that is, the plastic deformation.

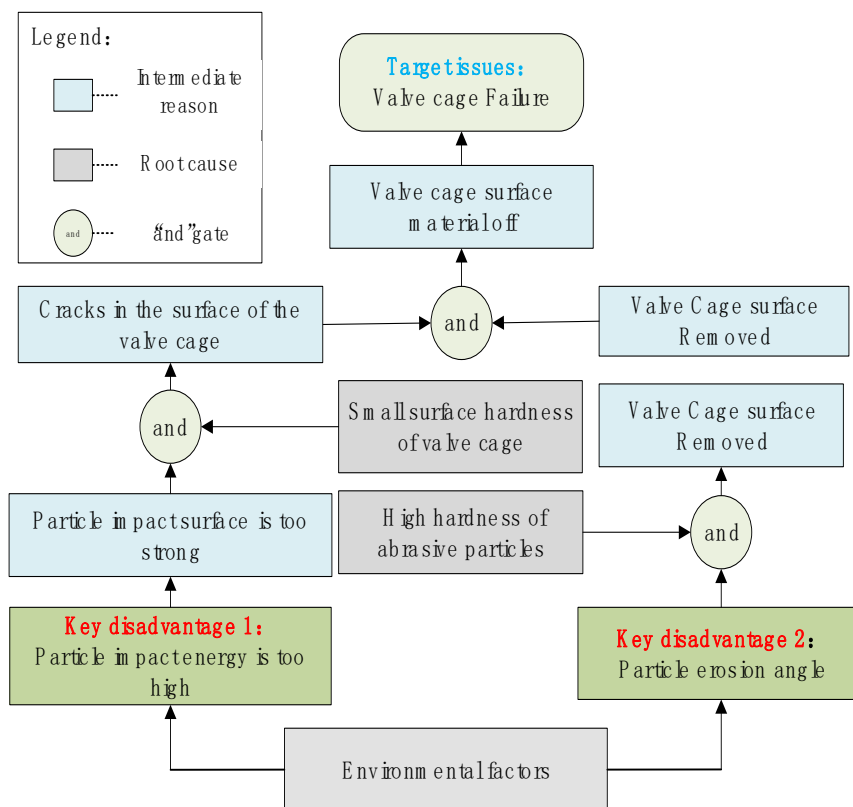


Fig. 2 CECA of the target problem

The CECA approach is illustrated in Fig. 2. CECA shows that the following two key disadvantages have been identified:

- (1) The impact energy of the solid particles is too high (for a cage). The kinetic energy of the particles comes from the energy of the fluid. The fluid energy is an engineering requirement that cannot be changed, but we can solve it from the aspect of absorbing and buffering energy.
- (2) The impact angle of abrasive particles is large and the impact area is large. This means that changing the surface morphology and reducing the impact angle and impact area can reduce the erosion area.

As can be seen from Fig. 2, CECA yielded four root causes representing either environmental factors or nature's laws (e.g. abrasive's material properties that cannot be changed). None of these root causes can be eliminated, which is normal for CECA.

4 Application of Innovative Tool

4.1 Cutting wear

The high-speed sandy fluid impacts the surface of the cage, and the solid particles impact the surface of the material at an angle, causing displacement and removal of the surface material. In response to this problem, it is still unclear on both sides of the contradiction, but the object field model can be used to represent and analyze the problem.

When the hydraulic valve is open, the flow of water will cause the sediment to impact the surface of the cage, which will cause wear on the surface. After continuous impact, the surface material will peel off and the cage will fail. Therefore, water flow and sand have a detrimental effect on the cage, which is a harmful effect model. The usual solution to the harmful intact model is to add a third substance S3 to prevent harmful effects, as shown in Figure 3.

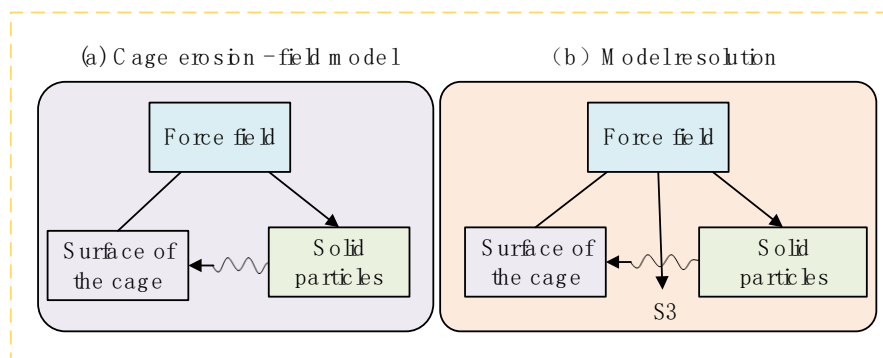


Fig. 3 Matter-field model and solution of valve cage erosion

Many living organisms have different surface morphologies that are formed by evolutionary optimization of organisms for hundreds of millions of years to adapt to their living environment. Desert scorpion can live in a desert environment for a long time, but its surface is not damaged. It is found that this is because its surface form has excellent wear resistance. Through microscopic observation, it is found that there are various macroscopic and microscopic structures on the back of the scorpion, such as groove structure and convex hull structure, as shown in Fig. 4. The convex hull and groove structure change the state of the near-wall flow field, and a "vortex" is created in the groove and an air cushion layer is formed. This special flow field state can change the trajectory of the sand and reduce the impact frequency of the particles and the surface of the target and the impact velocity of the particles, thereby improving the surface erosion resistance [4].



Fig. 4 (a) black-tipped scorpion; (b) on the surface of the scorpion's back, the concave and convex shapes and grooves can be clearly observed

By adding convex hull and groove (S3) on the surface of the valve cage, the erosion rate can be reduced, to change the condition of the near-wall flow field, so as to affect the velocity and trajectory of solids and ultimately reduce the wear of solids on the wall surface.

4.2 Plastic deformation

The erosion process is a process of energy dissipation, and the energy of the particles generally comes from the flowing medium that carries them. The material loss during the erosion process is due to the accumulation of plastic deformation. When the particles are incident perpendicularly, the target exhibits elastoplastic deformation. When the pressure of the contact area reaches the yield limit of the target, the crack of the subsurface layer of the material extends until the chip is detached.

In order to reduce the impact of the solid particles on the cage, the energy of the solid particles is dissipated. Therefore, the impact force and the energy of the solid particles are determined as a pair of technical contradictions, corresponding to the "force" and "the energy of the moving object" among the 39 parameters in the TRIZ. Therefore, the design problem is expressed as a TRIZ conflict: the force is improved and the energy of the moving object is deteriorated. The special principle of the invention can be obtained by looking up the Altschuler matrix table, as shown in Table 1.

Table 1

Contradiction matrix	
Contradiction	The amount of a moving object
Strength	10,17,19

The invention principle derived from the contradiction matrix: 10 is the pre-operation principle, 17 is the principle of dimensional change, and 19 is the principle of periodic action. After analysis, the principle of dimensional change can better solve this problem. Dimension changes have three meanings. One is to transform one dimension into two-dimensional, three-dimensional, and multi-dimensional. The second is to replace the single-layer structure with a multi-layer structure. The third is to use the other side of the given plane. Using the innovative principle of TRIZ theory and the corresponding biological function instance library, the biological example is searched. The results are shown in Table 2 below.

Table 2

Some biological instance libraries corresponding to dimension changes		
Serial number	Principles of TRIZ Invention	Biological function
		The arteries of giraffes
17	Dimension change	The laminated structure of the turtle shell
	

The carapace rib is the back of the sea turtle shell. It is a multi-scale leather carapace that has evolved to withstand the high-intensity events encountered in nature [5]. The carapace has a flat, sandwich-like layered structure. The dorsolateral cortex is composed of mineralized cortical outer bone, forming a solid material surface. The interior consists of a matrix of high-porosity trabecular bone, providing structural support and cushioning impact, as shown in Figure 5. The cuticle of the epidermis is an externally absorbing layer that protects the back of the bone; the flexible and porous interlayer is designed to absorb energy and resist multiple impacts.

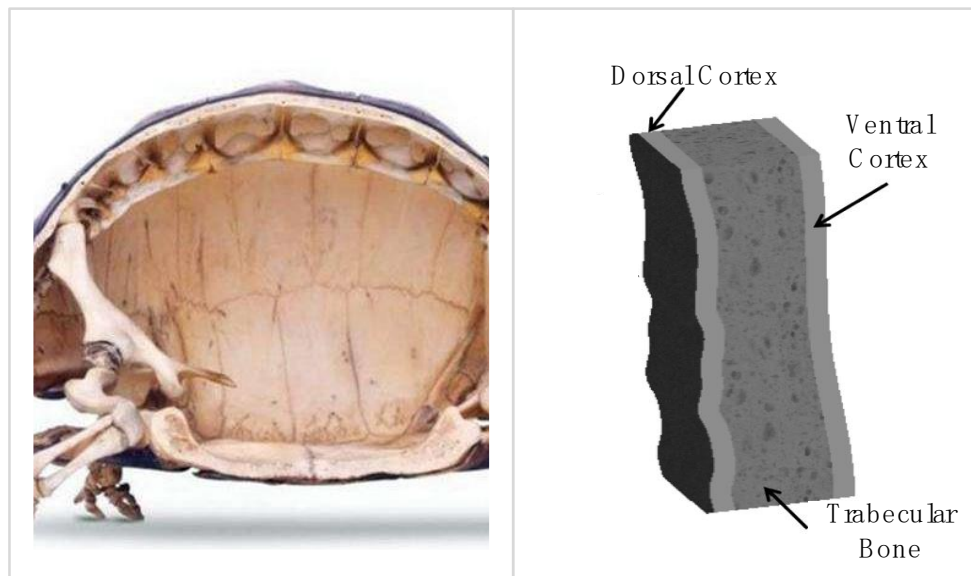


Fig. 5 A section of the carapace showing the composite layers(adapted from [6])

The "soft" and "hard" combined composite layered structure of the shell is extracted to establish a bionic anti-erosion cage model. The cage is a rigid-flexible sandwich structure with a hard outer layer sandwiched between a porous, soft intermediate layer. The high hardness of the outer layer can reduce the cutting wear; the flexible porous interior cannot only absorb energy, but also can collapse after the cavity collapses after compression, and its stiffness will be enhanced when it enters the dense section.

4.3 Multi-biological Coupling and Bionic Engineering Model

Under the rule of survival of the fittest and natural selection, after hundreds of millions of years of evolution, the organism optimizes a system that is highly coordinated with the living environment. This optimal adaptation to habitat is not the result of one or a few factors, but the result of multiple factors that are interdependent, mutually constraining and interacting. It is the result of the coupling of multiple factors such as body surface morphology, internal structure, and materials. This mechanism of action is called coupling bionics. The overall solution is obtained by combining the solutions of the different parts of the problem, where each part's solution comes from a different (biological) source.

The harder stratum corneum of the turtle's carapace, the corneal layer and the soft middle layer of the soft phase, the connective tissue, etc. together form a soft and hard composite structure. The hard phase can reduce cutting, and the soft phase can buffer the energy of sand or water erosion. The grooves and convex hulls of the surface of the scorpion can form turbulence, change the flow field of the boundary layer of the body surface, and change the trajectory of

the particles. The structure of these two organisms is coupled together and will have better erosion resistance.

In this paper, the structure of the regulating valve cage is improved according to the sandwich structure of the tortoise shell and the apparent shape of the carapace. Since the fluid in the valve carries particles from the inlet into the valve cavity, the particles collide elastically between the outer cage and the surface of the valve body cavity, causing multiple cutting phenomena. Therefore, the coupled bionic structure of the turtle shell and the scorpion is distributed on an annulus around the cage to alleviate the erosion wear of the solid cage on the cage structure. As shown in Figure 6.

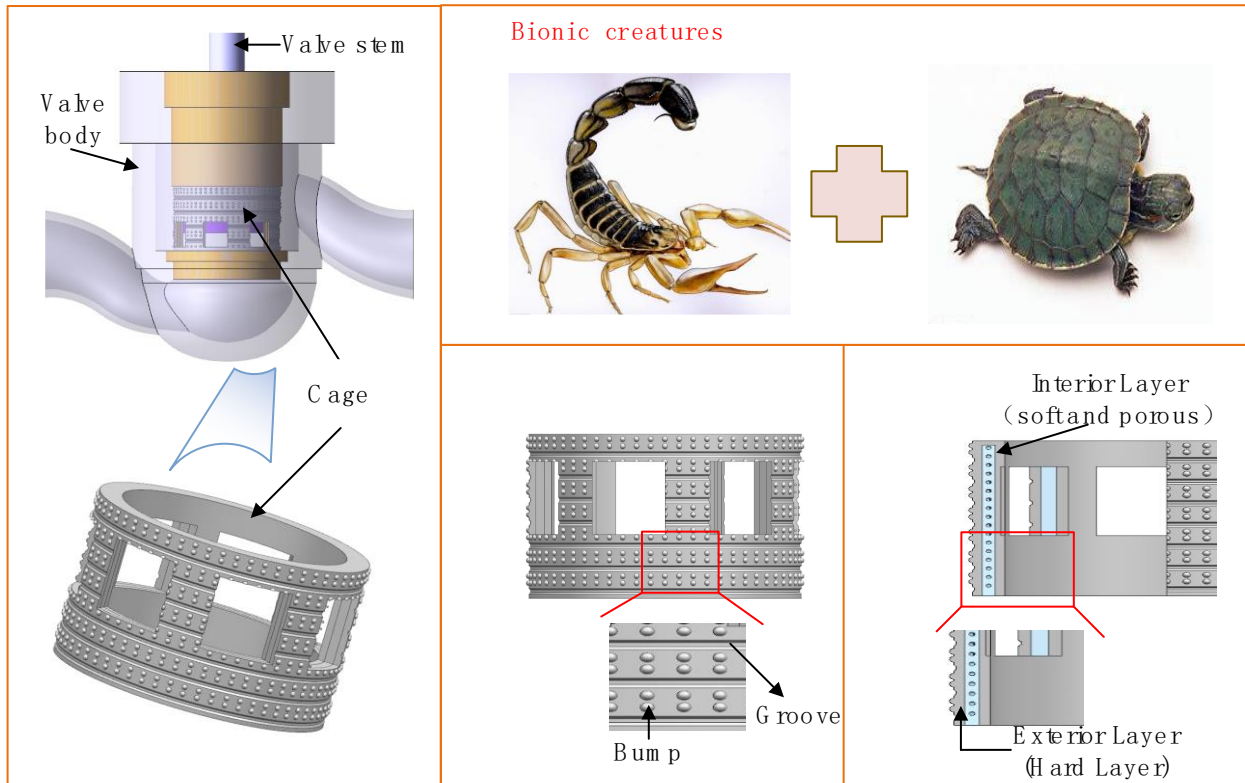


Fig. 6 Bionic valve cage

5 Application of Innovative Tool

Select the dice for similarity evaluation. The evaluation is based on three aspects: morphological structure, functional structure, and working environment. As shown in Table 3 below:

Table 3

Similarity analysis		
	Scorpion back armour wear-resisting system	Regulator cage corrosion resistance system
Morphological structure	The surface is convex and grooved	The surface is convex and grooved

Functional structure	Change the surface flow field, and then change the particle trajectory	Change the surface flow field, and then change the particle trajectory
environment	A turbulent, underwater environment with high - velocity currents	A turbulent, underwater environment with high - velocity currents

The similarity between scorpion and design target was calculated, and the evaluation factor set of weight coefficient was selected as $U=[u_1, u_2, u_3]=[Function, Structure, Shape]$. Based on the evaluation factor set and combined with the judgment matrix scale and scale table, the judgment matrix M is obtained as follows:

$$M = \begin{bmatrix} 1 & 3 & 4 \\ 1/3 & 1 & 2 \\ 1/4 & 1/2 & 1 \end{bmatrix}$$

The weight vector of $W=[0.9154, 0.3493, 0.1999]$ is obtained by finishing the calculation. $\lambda_{max} = 3.0183$, CI is calculated as follows:

$$CI = \frac{\lambda_{max} - n}{n - 1} = 0.00915.$$

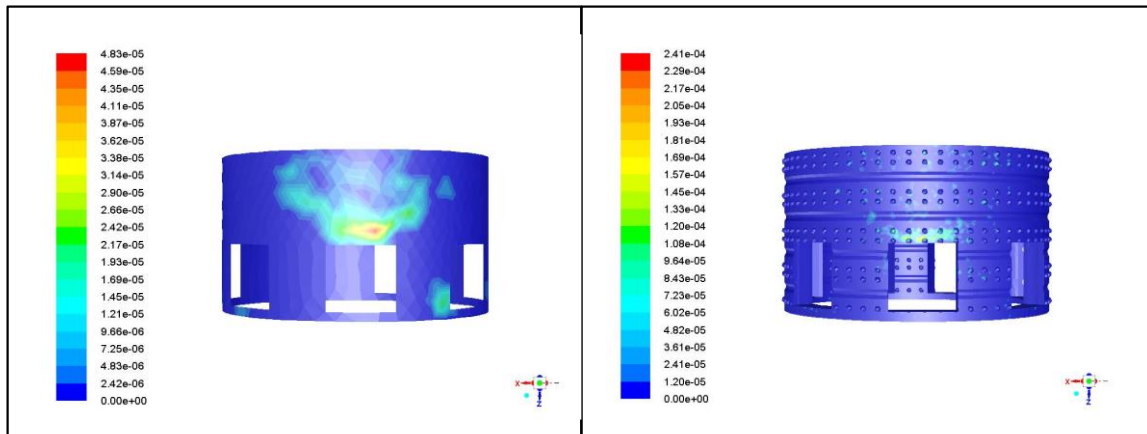
$RI=0.5149$, then the consistency ratio CR of the judgment matrix is

$$CR = \frac{CI}{RI} = 0.0178 < 0.1.$$

The similarity degree of scorpion's back armor and design target is $q=(0.7, 0.6, 0.5)$. The similarity between the biological prototype scorpion and the design target is $Q=0.9145 \times 0.7 + 0.3493 \times 0.6 + 0.1999 \times 0.5 = 0.9503$. Through the above similarity analysis and calculation, we know that there is a great similarity between the bionic target selected in this paper and the design target. The groove and convex structure of scorpion dorsal armor can be used as a biological prototype for bionic design.

6 CFD Simulation Verification

The flow direction of the fluid changes from high pressure to low pressure, resulting in obvious erosion on the outer layer of the cage. The entrance is directly subjected to the impact of high-speed solid particles. In the middle section perpendicular to the inlet, the particles pass through here to produce multiple collision cuts, and thus become the most severe area of erosion wear at this position. The simulation results of the ANSYS/Fluent module are in agreement with the actual, as shown in Figure 7(a). With the introduction of bionic structures, the area of the area where erosion wear occurs is significantly reduced.

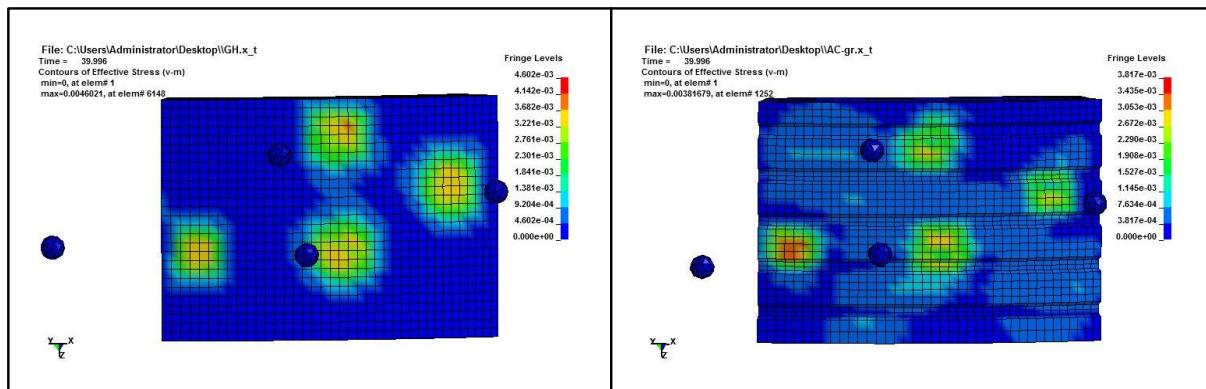


(a) No bionic structure

(b) Bump and groove structure

Figure. 7 The erosion cloud diagram of fluent simulation

To simplify the calculation and shorten the calculation time, select a part of the cage to simulate in the ANSYS/ LS-DYNA module. The erosion wear process of the cage with three-dimensional random multi-particle impact and the bionic layer was analyzed. The erosion resistance of the material is measured by the peak value of the equivalent stress. The larger the peak value of the equivalent stress, the more severe the yield damage and the more severe the erosion rate of the corresponding material surface. As shown in Fig. 8, the stress value reaches the maximum in 40 seconds, and the maximum stress value of the cage of the rigid-flexible coupling structure is significantly lower than that of the ordinary cage, that is, the erosion rate of the waterproof cage is reduced.



(a) No bionic structure

(b) Sandwich structure

Fig. 8 Equivalent stress cloud diagram of erosion wear

Through fluent and LS-DYNA simulation, it is shown that the bionic morphological surface and the rigid and flexible coupled sandwich bionic valve cage can reduce the erosion rate during erosion and wear, and verify the effectiveness of the bionic structure.

7 Conclusion

This paper studies and analyzes the cage parts of water hydraulic control valves that are highly susceptible to erosion. Using the innovative method of combining TRIZ theory and bionics, the

erosion resistance of the cage is improved from the surface morphology and composite layer. The new structure was simulated and analyzed by using two modules, fluent and LS-DYNA in ANSYS. In the fluent, by comparing the erosion parts of the common cage structure, it is found that the erosion of the new mechanism is about 50%. Using LS-DYNA software to simulate the erosion wear of the new cage structure, by analyzing the equivalent stress distribution diagram during the erosion wear process, the erosion resistance of the new mechanism is improved compared with the common structure, and the bionic structure is verified.

Acknowledgments

This work was supported by the Natural Science Foundation of China under Grant 51875113, Natural Science Foundation of the Heilongjiang Province of China under Grant F2016003, "Jinshan Talent" Zhenjiang Manufacture 2025 Leading Talent Project, "Jiangyan Planning" Project in Yangzhong City. This paper is funded by the International Exchange Program of Harbin Engineering University for Innovation-oriented Talents Cultivation.

References

1. A Y J, Kim B J, Shin B R. Numerical analysis of 3-D flow through LNG marine control valves for their advanced design[J]. *Journal of Mechanical Science & Technology*, 2008, 22(10): 1998-2005.
2. Lim C, Yun D, Park I, et al. A systematic approach for new technology development by using a biomimicry-based TRIZ contradiction matrix[J]. *Creativity & Innovation Management*, 2018.
3. Vincent J F, Bogatyreva O A, Bogatyrev N R, et al. Biomimetics: its practice and theory[J]. *Journal of the Royal Society Interface*, 2006, 3(9): 471.
4. Zhang J, Chen W, Yang M, et al. The Ingenious Structure of Scorpion Armor Inspires Sand-Resistant Surfaces[J]. *Tribology Letters*, 2017, 65(3): 110.
5. Achrai B, Wagner H D. Micro-structure and mechanical properties of the turtle carapace as a biological composite shield[J]. *Acta Biomaterialia*, 2013, 9(4): 5890-5902.
6. White Z, Vernerey F. Armours for soft bodies: How far can bioinspiration take us?[J]. *Bioinspiration & Biomimetics*, 2018, 13(4): 041004.

Communication

Communicating Author: chengmin@hrbeu.edu.cn

TRIZfest 2019

September 11-14, 2019. Heilbronn, Germany

STUDY ON THE TESE APPLICATION ROADMAP UNDER THE STRATEGIC DEVELOPMENT OF S-CURVE

Zhang Jing, Zhang Xiangmin, Guo Kai

^a *Henan University of Science and Technology, School of Management, Henan Luoyang, 471023, China*

^b *Non-ferrous metals common technology Henan Collaborative Innovation Center, Henan Luoyang, 471023, China*

Paper Classification:

- TRIZ-related methods and tools development
- Case study

Abstract

It is an urgent matter in market competition that to predict the future technology development and develop the products and next generation products rapidly. S-curve analysis and the evolutionary trends being the development mechanism under the S-curve are useful tools to understand the maturity of technology system and assist enterprises to make appropriate technology strategy. The different stage features of S-curve and the logic behind the S-curve were analysed in order to improve the efficiency of using evolutionary trend to guide the strategy formulation in different stages of S-curve. After combing the development trends of engineering system (TESE), the matching analysis between the strategic of S-curve each stage and TESE are studied based on the hierarchy of modern TRIZ TESE. Then the TESE application roadmaps are coming up to guide the strategy developments of S-curve more effectively. Subsequently, the case of Xiaomi smartphone was used to explain the method of TESE application roadmap.

Keywords: *S-curve, TRIZ, Evolution theory, TESE*

1 Introduction

With increasing intense global competition, companies need constantly adapt to market changes to provide new products or services to customers while maintaining continuous innovation to achieve rapid growth. When Deloitte surveyed the challenges faced by the rapid development of high-tech and high-growth enterprises in 2017 [1], it was found that the biggest challenge for the rapid development of enterprises was the fundamental change in the market demand of core products, followed by insufficient innovation capability, resulting in insufficient follow-up motivation for enterprise development.

Corporate performance is driven by different factors. Industry recovery, industrial restructuring and product mix adjustments, asset restructuring and cost reductions are all likely to increase

corporate performance. Behind these factors, improving innovation ability is the key to competition during the market. In addition to refining innovation to every aspect of operations, companies need focus on the development of markets and technologies in the selection of strategic priorities. Once the wrong direction of strategic development is made in technology, it leads to the outcome of “winning all competitors but losing to the times”, such as NOKIA and Kodak. Therefore, an emerging technology with accurate and detailed predictive capability is becoming more and more important for long-term development.

The S-curve is one of the laws governing the development of artificial systems and natural systems in the world. The S-curve describes completely the life cycle of a technical system. The evolution of each technical system follows the S-curve and goes through four phases: inception (1st stage), growth (2nd stage), maturity (3rd stage) and decline (4th stage). The technical direction that consumers most agree with in a certain period of time can be found through analysing the parameters of S-curves. Then patent portfolio can be done with this engineering system, and consumer habits can be developed ahead of time. Therefore, analysis of the S-curve helps to understand maturity of the technology system and assist the company in making the right decision of technology strategy. To understand the maturity degree of the technology system, it is necessary to know the evolution trend of the technical system. Among the invention methods, only TRIZ theory has the complete content of technological system evolution, which constitutes TRIZ's unique basic theoretical system [2]. However, there is no clear correlation between each evolutionary trend and each stage of the S-curve. When using the S-curve to formulate a product strategy, there are several technological evolution routes, which are required to use the trial and error methods, reducing the efficiency of the S-curve analysis method [3].

The rest of this work is organized as follows. Section 2 introduces the logic of S-curve, how to discern the stage of S-curve is important for enterprise. Hence, the work introduced the signs of every stage from classic TRIZ to modern TRIZ. Section 3 introduces The Trends of Engineering System Evolution (TESE) which come from TRIZ as the mechanism of S-curve evolution. Section 4 analyzes every stage strategy formulation using TESE, and extracts the TESE application map which can guide strategy formulation of S-curve. Section 5 introduces a case coming from Xiaomi to explain the usage of the apply roadmap of TESE in the strategy formulation process.

2 The Logic of S-Curve

With the rapid changing of the world, technological innovation is the main driving force for economic development. It is able to predict future advanced technologies and rapidly develop a new generation of products, which is very important for the survival and development of enterprises. As a company that can implement technology predictions, it has advantages in the following areas: (1) Defeating competitors and occupying the market early. (2) Implementing rational planning and resource allocation. (3) Increasing the effectiveness of market monitoring and obtaining market demand. (4) Maximizing profits and reducing costs to a minimum. (5) Improving product decision quality.

Product life cycle theory is one of the effective technology prediction theories. In 1965, the American economist Levitt first proposed the product life cycle theory in the Harvard Business Review: Products are going through the life process from birth to growth and finally death, like human beings [4]. For a product, its life cycle refers to the time from the start of the research to the complete exit of the market, and it is mainly affected by technological progress. For in

different life cycle stages, enterprises should take different strategies to the products. Therefore, the correct judgment of the product life cycle is crucial for enterprises to adopt reasonable industrial policies, and is also an important prerequisite for winning competition.

During the patent management work, Altshuller found that technological innovation has an inherent law in the industrial field [5]. Technological change and innovation are as well-documented as the life laws of living organisms. There are technological evolution processes of the infancy, growth, maturity, and decline totally four stages and the process was described by S-curve, shown in Fig. 1.

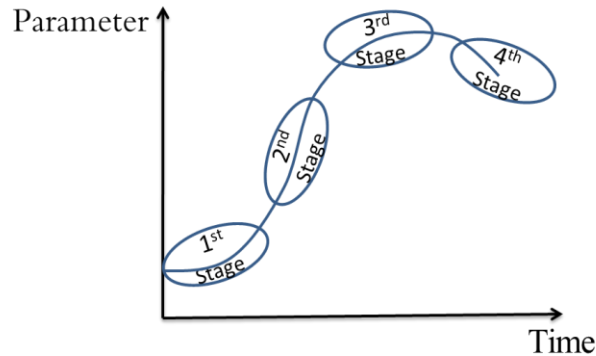


Fig. 1 The trend of S-curve evolution

When a new technology has just appeared, the performance of its products is usually poor. With developing the technology, the product performance is continuously improved. In the growth period, product performance has the fastest growing, but more slowly in the maturity periods. To the decline period, product technical performance begins to decline, and the product will be gradually withdrawn from the market.

In order to do technical forecast and get the development strategy of the product by S-curve, it is better to know what is the sign of an engineering system in a particular stage and then determine the phase of the product life cycle.

There are four indicators to determine the position of the engineering system on S-curve, which contain about the number of patents, the level of patent, profit and performance in the classic TRIZ theory. Taking the indicator of profit as an example, enterprises often have little profit when the application of a new technology has just been introduced. Corporate profits are negative in the infancy period (1st stage). In the growth period (2nd stage), although technology is not mature, its market advantages have emerged. Therefore, enterprises become profitable, and the profits will continue to increase and reach the maximize during the maturity period (3rd stage). With the arrival of decline (4th stage), profits begin to decline.

Some of the indicator are difficult to collect and judge, for example, patent level. Therefore, the judgment of product life stage is often subjective. In order to improve the accuracy of stage judgment, the stage indicators of S-curve are no longer used by the patent number and patent level, but by the performance of the engineering system in the market, that are the trend of the main parameters of value, the technical maturity and other auxiliary indicators which are more scientific and accurate. Among these indicators, the parameter of MPV (Main Parameters of Value) is the key attribute of a product/service. So now, the vertical axis of S-Curve is built for one or more MPVs.

After judging the development stage of the engineering system, there will be another problem, that is, what are the best approaches for improving and developing the system.

Therefore, we should know the evolution mechanism of S-curve. The evolution mechanism of S-curve is that determines where an engineering system is developing and what steps should be taken to improve it. Because of the importance of MPVs, the trend of increasing value is the driving force behind all technological developments.

3 TRIZ tool –The Trends of Engineering System Evolution (TESE)

Based on the premise of technology evolution, TRIZ was developed by Genrich Altshuller and his colleagues. The way to invention is not a random process, but it is predictable and governed by certain laws[6,7]. These regularities were translated into patterns of evolution and useful for developing good solutions to problems, predicting how systems would evolve [3].

Understanding the patterns of evolution can help in forecasting technology development and identifying features that are likely to be successful in newly launched products. Applying these trends to guide technology systems can reduce innovation risks, for that these trends have been proven successful in patent.

3.1 Classical TRIZ Evolutionary Trend and Its Relationship with S-curve

In 1970s, Altshuller proposed the theory of engineering systems evolution trends [8]. There are nine distinct trends that guide engineering system development, and they are divided into three groups, namely ‘static’, ‘dynamic’, and ‘dynamic state’ [9]. The researchers pointed out that the three trends in the ‘static’ group are the necessary criteria and conditions for the generation and existence of any technical system. The trends in the ‘dynamic’ and ‘dynamic state’ groups are the regularity of the development of engineering systems. As is shown in Table 1. Furtherly, each trend divides into lines of evolution [10].

Table 1 Technological system evolution trend and its classification

Number	Classification	Classical TRIZ Evolutionary Trend	
1	Criteria for the generation and existence of engineering systems	The Trend of Increasing Completeness of System Components	
2		static	The Trend of System Energy Transfer
3			The Trend of Increasing Coordination of System Components
4	The law of the development of engineering system	The Trend of Increasing Ideality	
5		dynamic	The Trend of Uneven Development of System Components
6			The Trend of Evolution to Super Systems
7		dynamic state	The Trend of Evolution toward Micro- Levels
8	The Trend of Increasing Dynamization of Substance and Field		

According to this classification, S-curve of the development of any engineering system has two stages under the guidance of nine trends, shown in Fig.2.

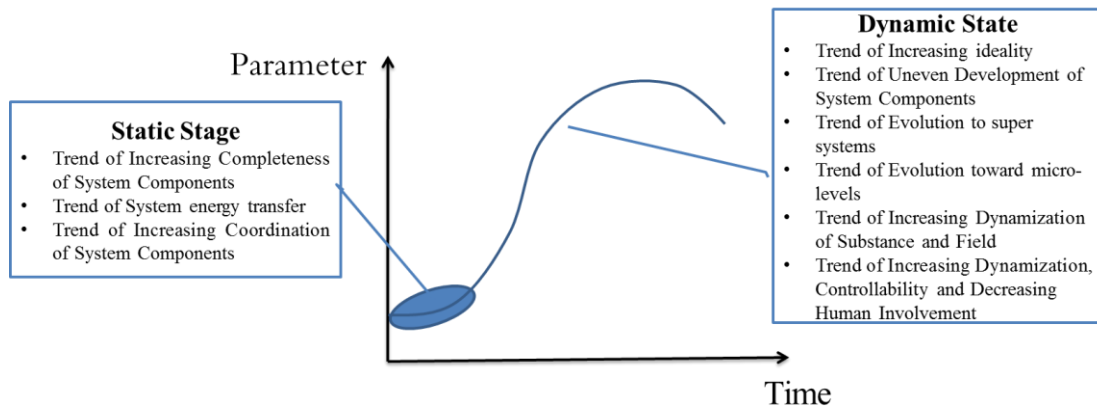


Fig. 2 Relationship between Classical TRIZ Evolutionary Trend and S-curve

(1) Static Stage

Static Stage is the generation and existence stage of engineering systems. The system needs to be designed and produced. At this stage, we mainly concerned about the change of composition of system components, including the elements that make up the system, the distribution of system components and the characteristics of their relationship with each other. The formation of the system is the process of coordination of all components and implementation device and the parameters of the object. Therefore, the stage is static, and it can be guided by the trends of Increasing Completeness of System Components, System energy transfer and Increasing Coordination of System Components[9].

(2) Dynamic Stage

Dynamic stage is the development and completeness stage of engineering system. After coordinating the components and their parameters in the previous stage, the system changed from a simple 'sum of elements' to a 'functional technology system', that is, the system began to test the new scheme and compare the operating parameters of the old and new systems. During the development of the system, the change of its operating parameters and ideal degree are changed dynamically with S-curve[9]. So it can be guided by the trends of No.4-9 in Table 1.

The classical TRIZ evolutionary trend is divided into two stages in general. It improves the guidance of application between evolution trend and the S-curve to some extent. However, there are many problems in the strategy formulation process of S-curve in different stages guided by the classical evolutionary trend.

Firstly, the classification of two stages and three groups is too general, which is not conducive to the strategy implementation of the 2nd, 3rd and 4th stages of S-curve. Secondly, the first stage is static for production, but it is not static for the trend. Therefore, The trend of system

energy transfer and The trend of increasing coordination of system components can be also used in stage 3 and 4. Thirdly, the logic relation of each law is not clear, and the function of each law is not clearly defined in each stage of S-curve. Finally, the lack of operable steps and algorithms in the application of the evolutionary trend to solve specific engineering problems has reduced the predictability of the method.

3.2 Modern TRIZ Evolutionary Trend and Its hierarchical architecture

In view of the fact that there is no clear logic structure in the classic TRIZ evolutionary trend, Petersburg school of Russia has made a certain adjustment to the evolutionary trend. The trend of S-curve evolution is the highest evolution trend, and the trend of increasing value is the driving force behind the development of all technology. Therefore, the trend of increasing value is a subtrend of the trend of S-curve evolution. All other trends are subtrends of the trend of increasing value [8,11]. There are some adjustments to the evolution trends. The trend of system energy transfer was changed to the trend of flow enhancement. The Trend of Increasing Degree of Trimming came out of The Trend of Evolution to super systems. The Trend of Evolution toward micro- levels and The Trend of Increasing Dynamization of Substance and Field are combined to The Trend of Increasing Dynamization. Finally, the hierarchical architecture system consisting by 11 evolutionary trends was formed, shown in Fig. 3.

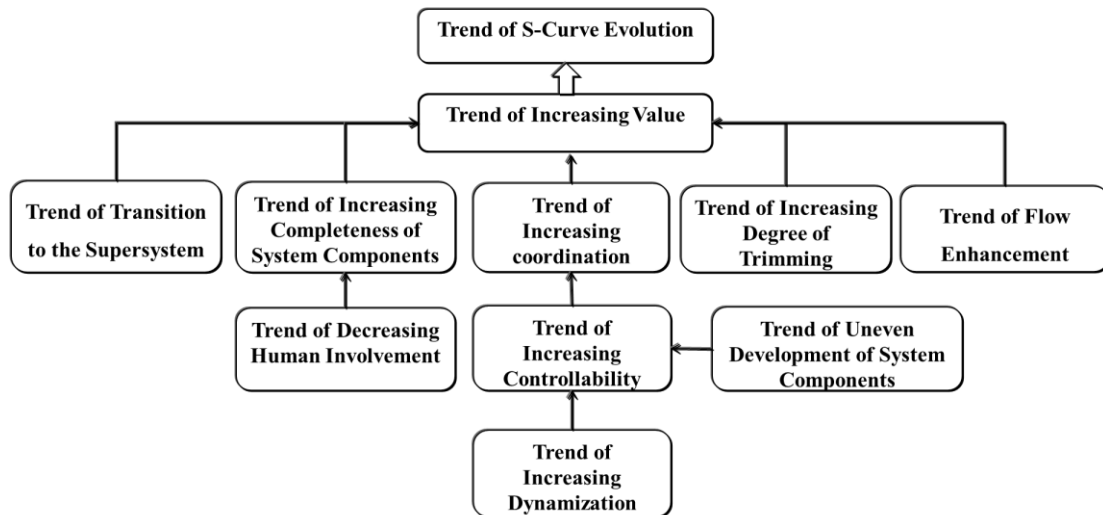


Fig. 3. The hierarchy of Modern TRIZ Evolutionary Trends

Although the hierarchy of modern TRIZ evolutionary trends is relatively clear, there is no clear correlation between each evolutionary trend and each stage of the S-curve. When using S-curve to make product strategy, there are many technological evolution routes. Trial and error method is needed, which reduces the method efficiency during the strategic decision-making.

4 S curve product strategy formulation and TESE application roadmap

4.1 The matching analysis between strategic demand of s-curve each stage and TESE

The evolution of the S curve is driven by value. An engineering system evolves so that its value always increases. Value=(total functionality)/(total cost). See (1)

$$V=(\sum F)/(\sum C) \tag{1}$$

The way to increase value is different at different stages of the S-curve, so the strategies that should be adopted are not the same.

(1) The 1st Stage

The engineering system is “born” when the principle of action is first applied to deliver its main function. At this stage, the development of the engineering system is constrained by shortages of resources. Therefore the system design and system components are not refined, and there exist bottlenecks in the engineering system which makes it unmarketable. Meanwhile, costs outweigh revenue. Our aim is to increase the function and decrease the cost.

At this stage, the technology is still in development, and it has disadvantages that prevent or at least limit success on the market. Hence we should identify and eliminate bottlenecks that keep the engineering system off the market under existing infrastructure and resources. Combining with alternative systems maximizes strengths and minimizes weaknesses [11].

Trend of transition to the super system mainly focus on what components and how they can be integrated. The first two subrends include different parameters and different main functions of engineering system, especially combining with competing engineering system. We can use these two subrends to find the components which can be integrated.

(2) The 2nd Stage

This is a dynamic stage with MPVs improving rapidly. Based on expectations of profitability, substantial funding is invested in the development of the engineering system, and all resources available for development start being utilized. Engineering system variations become more widely differentiated in designs. Once demand has increased and mass production is under way, and super system elements start adapting to the engineering system. So our aim is to increase functionality, with little or no increase in cost [11].

In this stage, our strategy is to have different design with the same basic function, and then expand the basic function to new applications. At the same time, it is possible to focus on compromises and solutions aimed at minimizing disadvantages.

To implement these strategies, firstly, when we have different designs, on the one hand, we can use the trend of transition to the super system to have different parameters and expand new functions. on the other hand, the trend of increasing coordination can help system coordinate with super system from shape、rhythms、materials and actions. Secondly, in the first stage, system maybe only has operating agent, and other functions are coming from super system. In order to increase functionality, trend of increasing completeness of system components can help system component become more completeness. With the function increase, it should be increased controllability and dynamization. So the trend of increasing controllability and trend of increasing dynamization can help us to forecast the function development. In order to minimizing disadvantages combine with the development of function, the trend of flow enhancement can be used to reduce negative effects of harmful flows.

(4) The 3rd Stage

Engineering system development slows enormously, and engineering system starts running up against development limits, which contain about the physical limits, economic limits, user limits, super system limits and so on. With the rapid development in the second stage, many super system components are designed to accommodate the engineering system, and the engineering system consumes highly specialized resources. Engineering system variations differ from one

another mainly by design, and acquires additional functions that are of little relevance to the main function [11]. Our aim is to decrease cost with little or no change in functionality.

In this stage, first we should reduce costs, develop service components, and improve aesthetic design in the near and medium term. Second in the long term, the strategy is to resolve contradictions by switching to another principle of operation for the engineering system or its components. Third deep trimming, integration of alternative systems, and other techniques of transition to the super system are highly effective.

Primarily, trend of increasing coordination can be used to improve aesthetic design and personalized development strategy. For example, we can establish ecomodel and/or sharing platform and then super system components can be designed to accommodate the engineering system by acquiring complementary resource with using subtrends of complementary rhythms. The subtrends of special rhythms can be used to develop service components and customized service strategy. Then, the trend of increasing degree of trimming can be used to reduce cost. Finally, when we integrate with alternative systems, the trend of transition to the super system tells us the types of integrating engineering systems different in parameters and functions, and how to integrate with engineering systems.

(4)The 4th Stage

Engineering system functionality and revenue decline in this stage. More effective systems have reached their 2nd stage of evolution and are beginning to force the system out. Super system changes reduce the need for the engineering system. The main function of the engineering system loses its utility, so the engineering system becomes non-utilitarian: an entertainment, a decoration, a toy, or sports equipment. The engineering system continues to function only in highly specialized fields. So our aim is to decrease functionality, with much more decrease in cost [11].

The strategy in this stage is looking for the niche market and other recommendations are the same as for 3rd stage. So the trend of increasing degree of trimming can be used to decrease functionality, and at the same time reduce much more in cost.

4.2 TESE application map

In order to obtain a functional technology system with new working ability as the system is improved each time, Altshuller pointed out that the new system solution needs to meet three conditions in stages [9].

- (1) Ensuring that the components of the system correspond to the functions performed.
- (2) Determine the interaction between the components of the system.
- (3) Coordinating the parameter of engineering system subsystem.

Each phase of the s-curve accumulates and coordinates the resources needed to complete the function in each phase. As the existence condition of the system is satisfied gradually, the coordination of the parameters and working state of the system is improved. Under the three conditions above, different evolutionary trends apply to different stages.

In the 1st stage, the Trend of Transition to the Super system can guide us to choose what parameters and functions to complement the engineering system.

In the 2nd stage, the Trend of Transition to the Super system, the Trend of Increasing Coordination, the Trend of Increasing Completeness, the Trend of Increasing Controllability, the Trend of Increasing Dynamization and the Trend of Flow Enhancement, all of the above trends can help to increase the function.

In the 3rd stage, The Trend of Increasing Coordination and the Trend of Transition to the Supersystem can be used to increase function. The Trend of Increasing Degree of Trimming can be used to reduce cost.

In the 4th stage, the Trend of Increasing Degree of Trimming can be used to decrease functionality, and at the same time reduce much more in cost.

The Trend of Uneven Development of System Components can be used to guide the whole S-curve evolution. In the 1st stage, the main functions focuses on the implementation tools; in the 2nd stage, engineering system development focuses on improving the auxiliary functions and influence the super system increasingly; in the 3rd stage, engineering system development focuses on the functions that are not related to the main functions; in the 4th stage, the function of the engineering system transform to entertainment and so on. TESE application map is shown in Fig. 4.

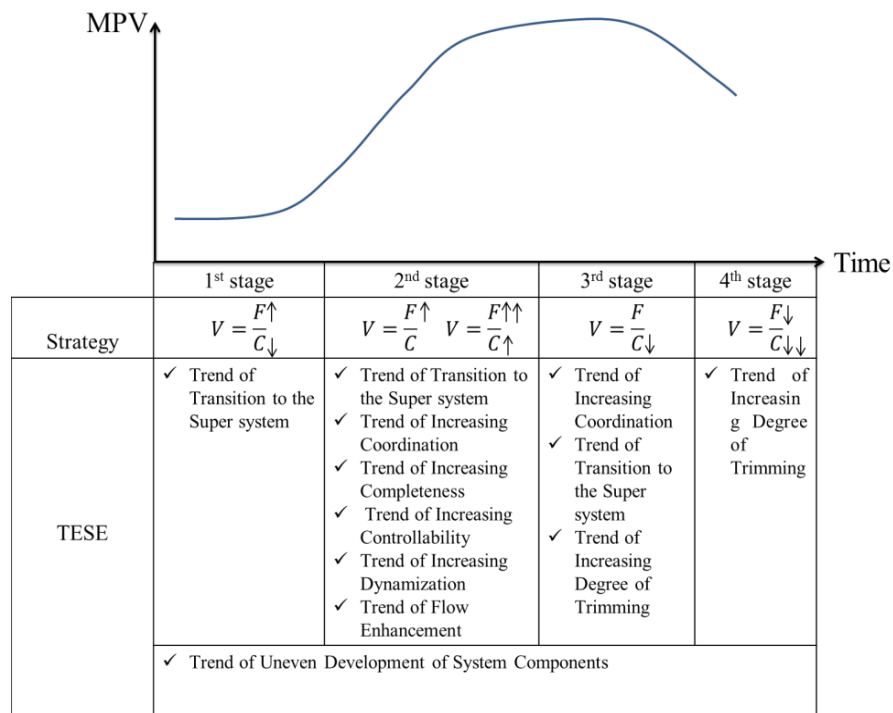


Fig. 4. TESE application map

5 Case study

From the growth experience of Xiaomi, it is undoubtedly the benchmark of Internet technology "unicorn" enterprises in China. Xiaomi was founded in the year of 2010; Xiaomi first smartphone M1 product release in 2011; In 2014, Xiaomi phones ranked first in China's smartphone market in terms of sales volume (about 15% market share) for the first time. Now, after a brief trough of Xiaomi mobile phone business and a precipitation period of iec ecological chain layout, Xiaomi shipped back to the top five of the world smartphone market in terms of

sales volume. According to IDC data, Xiaomi ecological chain company sales reached 20 billion in the year of 2017. "The home of Xiaomi" new retail channel layout shows that Xiaomi has a growth momentum, and is expected to become the indispensable emerging domestic Internet technology after BAT. In order to analysis Xiaomi smartphone S-curve strategy, let's look at the products development history from Xiaomi startup, shown in Table 2.

Table 2 Xiaomi products development history

Time	Products and Important Events
2010	Startup
2011	Xiaomi smartphone 1, MIUI, Michat
2012	Xiaomi smartphone 1s, Xiaomi smartphone 1s (youth version), Xiaomi smartphone 2
2013	Redmi smartphone, Xiaomi smartphone 3, Xiaomi TV
2014	Redmi note, Xiaomi smartphone 4, Xiaomi pad, Xiaomi air cleaner, Intellilamp, MI Band
2015	Redmi smartphone2, Xiaomi note, pianjing, Mi plugboard
2016	Xiaomi smartphone 5, Redmi pro, Xiaomi laptop Air
2017	Xiaomi smartphone 6, Redmi 5, Xiaomi laptop pro
2018	Redmi 6, Xiaomi smartphone 7

In the 1st stage, when Xiaomi was startup, the market penetration and shipments of smartphone are increasing rapidly. Xiaomi launched the first-generation products smartphone 1. It improved the function not only from hardware, but also add the function of Michat and MIUI. In this way, Xiaomi improved the function. At the same time, Xiaomi adopted minimalist design to reduce cost. Hence, Xiaomi smartphone 1 was a cost-effective hot style product.

In the 2nd stage, the global and Chinese smartphone market gradually entered the stock period, and it needed to enter the stage of "quality improvement". The differentiation of product appearance and function became a new development trend, which promoted the continuous improvement of smart phone market price. With the Trend of Increasing Coordination, there were smart phones with different screen sizes from 4.0 inch to 6.5 inch, and the image was also increasing coordination from 750×1334 pixel to 1440×2880 pixel. With trend of Increasing Dynamization, the screen of the smart phones are undergoing from straight screen, folded screen to curved screen. In the meantime, Xiaomi began to lay out new products to affect the super system, and super system elements start adapting to the Xiaomi products. Take the Xiaomi TV, Intellilamp, and MI Band as examples, smart phones can control these products, and the smart phones started consuming the specific resources. The products lay out meet the Trend of Transition to the Super system, Trend of Increasing Controllability, and Trend of Increasing Completeness. At this stage, the Trend of increasing value was transferred from (2) to (3). See (2) and (3).

$$\text{higher cost performance} = \frac{\text{Adequate function}}{\text{Absolute low price}} \quad (2)$$

$$\text{higher cost performance} = \frac{\text{performance, design, materials...}}{\text{reasonable price}}. \quad (3)$$

In the 3rd stage, Product ecological expansion along the three circles of ‘mobile phone peripheral — smart hardware — lifestyle’. Xiaomi is expanding mobile phone peripheral products, such as mobile power supply, earphones, protective cases, around different consumption scenarios of mobile phones; At the same time, Xiaomi also focuses on home intelligent hardware products, such as AI audio and video, smart TV, air cleaner, balance car, Intellilamp, etc. In addition to intelligent hardware products, functional consumable products such as towels, bags, signature pens and mattresses have also been developed. From intelligent hardware to living supplies, Xiaomi will create a ‘MI fans’ lifestyle in an all-round way. Xiaomi is under gonging the Trend of Transition to the Super system and Trend of Increasing Coordination, especially coordination complementary rhythms. In order to reduce cost, the packaging requirements of Xiaomi phones include simple structure, reasonable design, environmental protection material selection, and meet the requirement of e-commerce of impact and compression resistance. Although Xiaomi is improving its products aesthetic design, the appearance of different products is kept unified, shown in Fig. 5. At this stage, Xiaomi is gradually developing its service components, and Xiaomi has become an eco-company.



Fig. 5 the aesthetic design of different Xiaomi products

In the 4th stage, While China's smartphone growth has slowed, emerging markets in the asia-pacific region, such as India, are still in a period of high smartphone growth, maintaining double-digit growth. In 2017, Xiaomi expanded its overseas market again, especially in India, Russia, Ukraine and other markets, and achieved surprising results.

6 Conclusions

The technological strategy made by S-Curve and TESE has become a key weapon for enterprise competition. When developing a technology strategy, it is better to understand the logic of S-Curve and the mechanism behind it. TESE describe the natural transitions of engineering systems from one state to another, and it provides the theoretical underpinnings for many TRIZ product innovation tools. The unclear correlation between S-curve and TESE reduces the method efficiency when doing strategic decision-making. Based on the analysis of the causes, indicators and recommendations, the TESE application map was come up. Xiaomi products layout was used to explain the usage of TESE application map.

Acknowledgment

I would like to thank to Sergei Ikovenko for providing me with a lovely contact to TRIZ, for all his unconditional support whenever I came to him with any TRIZ related issue, and for the research direction that he gave me.

The author would like to acknowledge the financial support Innovation Method Special Work of China Ministry of Science and Technology (No. 2017IM060100).

References

1. Deloitte: China's top 50 high-tech and high growth report for 2017,2017.
2. <https://www2.deloitte.com/cn/zh/pages/technology-media-and-telecommunications/events/technology-fast-50-china-report.html>
3. Li S. B., Mou J. H. A Research for Evolutionary Process Based on TRIZ Evolution Theory[J]. Applied Mechanics and Materials, 2010, 20-23:1328-1335.
4. Ilevbare I. M., Probert D , Phaal R . A review of TRIZ, and its benefits and challenges in practice[J]. Technovation, 2013, 33(s 2-3):30-37.
5. Levitt, Theodore, Exploit the Product Life Cycle. Harvard Business Review[J].1965 (November-December):81-94.
6. Altshuller, G.,1996. And Suddenly the Inventor Appeared. Technical Innovation Centre, Worcester, Massachusetts., Originally published in Russian, 1984.
7. Eversheim W, Baessler E, Eversheim W, et al. Innovation Management for Technical Products[M]// Innovation Management for Technical Products: Systematic and Integrated Product Development and Production Planning. 2009.
8. Cowley M. Simplified TRIZ - New Problem-Solving Applications for Engineers and Manufacturing Professionals[J]. Tqm Magazine, 2002, 18(3):311-312.
9. Zhang Min, Zhang Wucheng, Wang Guanshu. TRIZ Enhancement and Practical Applications[M]. China Mechine Press,2018.
10. Nikolay Shpakovsky. Evolutionary Tree[M]. China Science and Technology Press,2010
11. Yang C J, Chen J L . Forecasting the design of eco-products by integrating TRIZ evolution patterns with CBR and Simple LCA methods[J]. Expert Systems with Applications, 2012, 39(3):2884-2892.
12. IWINTALL.INC. MATRIZ Training handouts, 2019.

Communication

Communicating Author: zhangjinghaust@163.com

TRIZfest 2019
September 11-14, 2019. Heilbronn, Germany

TALKING ABOUT THE PRACTICAL APPLICATION OF THE STANDARD SOLUTION

Xiaofang Su, Na Yu, Feng Qiang, Ye Wang, Li Lv

Zhuhai, 519000, China

Paper Classification:

- Theoretical, research results
- Educational methods and experiences
- Case study

Abstract

TRIZ (inventing problem solving theory) is a scientific approach to innovation that uses analytical tools to identify the root causes of innovation barriers and then find practical, fast, effective and low-risk solutions. A good R&D tool, can accelerate the speed of product R&D, improve R&D ability and patent innovation level. This paper mainly studies the method flow of combining TRIZ functional analysis and field analysis to solve engineering technical problems, and improves the ability of practical problem solving, so as to get the solution quickly and effectively.

Keywords: *TRIZ, Standard solution, Field analysis, Cutting method.*

1 Project

TRIZ Chinese translation for invention problem solving theory. It is a scientific method to implement innovation. It USES analysis tools to discover the root causes of innovation obstacles and then find feasible solutions that can be applied quickly, effectively and with low risks [1]. In this paper, the viewpoint of combining functional analysis and object field model is put forward, that is, incomplete, excessive, insufficient and harmful functions after functional analysis or function cutting are directly analyzed and solved by corresponding object field model. The standard solutions of the second and third categories are adopted for functional deficiencies. The incomplete function adopts the standard solution of sub-category 1.1. The function is harmful to adopt the standard solution of sub-category 1.2. The fourth type of measurement function are used, and the fifth type of standard solutions are used for function optimization .

2 Content

2.1 relationship between object field model and function [2]:

2.1.1 we usually use S1 to represent the object substance (Object 1), S2 to represent the instrument substance (Object 2), and F to represent the field. Under the influence of some energy given by field F, S2 forms a useful function (F_U) or a harmful function (F_h) after sending an action to S1.

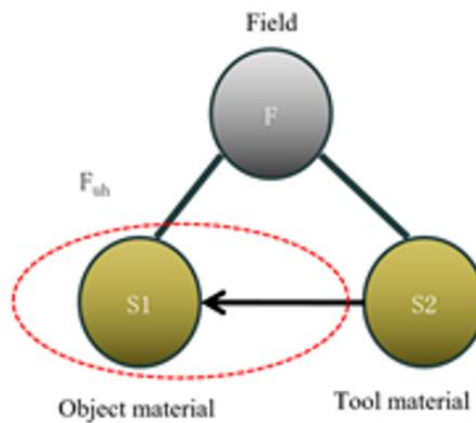


Fig. 1. The relationship between object field model and function

2.1.2 Problem model: there are four problem models in the field model and function: incomplete, excessive, insufficient and harmful;

2.1.3 Description:

(1) A model material field model is a substance for another interaction, its description of S (1) + F (field, The action V) + O (Item 2) + P (implied parameters), the description is usually omitted P, for example, electric furnace (S) by thermal field (F) role in water (O), its a matter of fact, the parameters of the water (temperature) changed, thermal field is action;

(2) Function description: complete description: S (object 1) + V (action) + O (object 2) + P (parameter), usually omit S (object 1), such as raising the temperature of water, or it can be described as electric furnace (S) changing the temperature (parameter) of (V) water (O);

So, the objects field model and the function are essentially the same, but they are described in different ways.

2.2 Problem-solving process:

In view of the same nature of object field model and function, this paper puts forward the view of combining function analysis and object field model, that is, incomplete, excessive, insufficient and harmful functions after function analysis or function cutting are directly analyzed and solved by corresponding object field model. The standard solutions to the second and third categories are adopted for functional deficiencies; the standard solutions of the first 1.1 subcategory are adopted for functional incompleteness; the standard solutions of the second subcategory are adopted for functional harmfulness; the standard solutions of the fourth subcategory are adopted for measurement functions; and the standard solutions of the fifth subcategory are adopted for functional optimization. The following will introduce the specific problem solving process. The specific process is shown in figure 2 below.

2.2.1 Problem description: describe when, where and under what circumstances the problem occurs, and understand the physical principles, chemical principles, geometric principles and biological principles involved in the problem. Only by understanding the nature of the problem can the problem be more clearly defined.

2.2.2 Final ideal solution (IFR) : the purpose of determining the final ideal solution is to determine the goal of the project, which will guide the direction of subsequent problem solving.

2.2.3 Function analysis: function is the preset purpose of product research and development, and what the customer needs is not the product itself but the function. Through function analysis, the functional defects in the technical system can be understood, so as to determine the direction to solve the problem;

2.2.4 Function tailoring: the purpose is to eliminate excessive, harmful and repetitive functions so as to improve the ideality of the system;

2.2.5 Field analysis and 76 standard solutions: establish the problem model, find the corresponding solution model, and get the solution through inspiration.

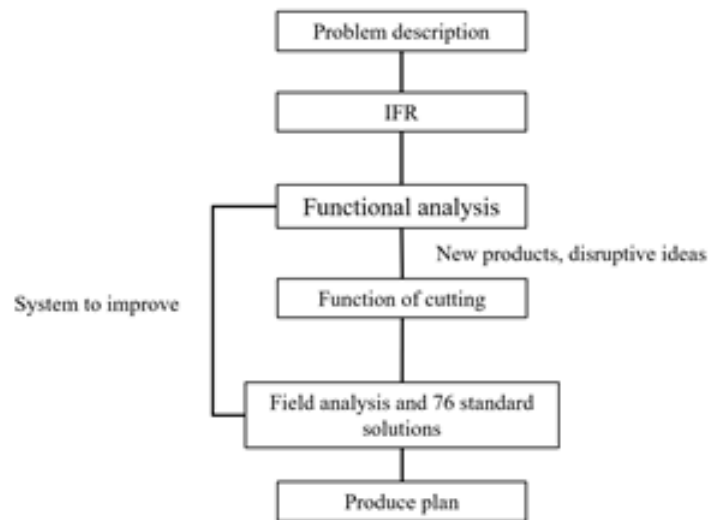


Fig. 2. The problem solving process

2.3 Comprehensive application of standard solution method:

In order to enable readers to have a deeper understanding of the application of the standard solution in the problem solving process in the actual project, the next step is to take "mousetrap" as a case to make the field analysis and solution.

2.3.1 Determination of problem types:

Description: a standard spring-loaded mousetrap is very effective, but is dangerous to pets, children, and even adults. And we don't want that kind of blood at home. The physical principle is to trap mice by pressing them down mechanically.

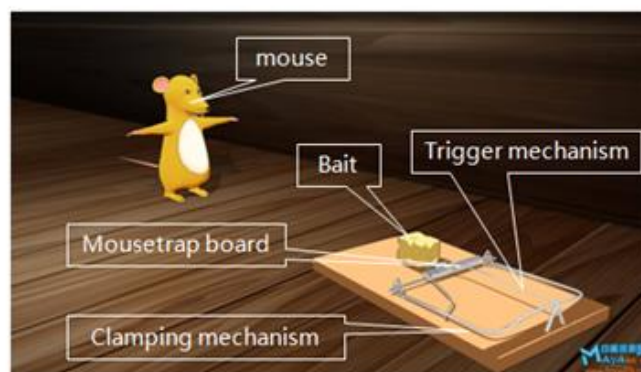


Fig. 3. Mousetrap and mouse

The final ideal solution (IFR):

- 1) rats do not exist;
- 2) the mousetrap can only catch mice without hurting people or pets, and there is no bloody scene.

2.3.2 Process analysis: we understand the functions of each component by analyzing the use process of the mousetrap. Of course, advanced analysis methods can also be used for analysis -- process-based functional analysis combined with tailoring methods. I won't go into detail here.

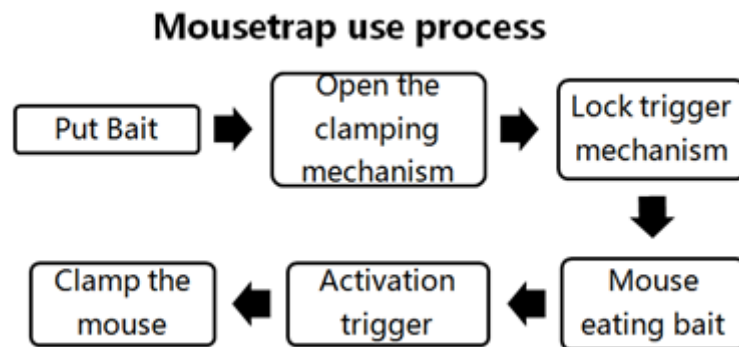


Fig. 4. Mousetrap use process

2.3.3 Component analysis and resource analysis: generally, the system to be improved or can be improved is selected as the engineering system, which needs to be selected according to the actual situation. Components that cannot be changed or exist objectively are generally referred to as supersystems. For example, in this case, the mouse, which is objective, cannot change the existence of the species, so it is generally used as a component of the supersystem. If you want to make a subversive change to the original scheme, it is recommended to select the simplified mechanism (to combine multiple components with little improvement into one component), because the more detailed the components are, the more complex the subsequent analysis will be, the lower the efficiency will be, and the effect will be worse. If you want to make local improvement to the original scheme, it is suggested to divide the system components as fine as possible, so as to better find the breakthrough point of the problem, that is, the root cause of the problem, and thus improve the function of the system. In this case, the mousetrap is selected as an engineering system, and the interaction between system components and supersystem components is analyzed.

System component analysis:

Table 1

Component Analysis

Component analysis		
Engineering system	System Components	Super system component
Mousetrap	Trigger mechanism	Bait

	Clamping mechanism	Mouse
	Mousetrap board	Pet

Table 2

Interaction Analysis

Interaction analysis						
From\to	Trigger mechanism	Clamping mechanism	Mousetrap board	Bait	Mouse	Pet
Trigger mechanism		Maintain		Support		
Clamping mechanism					Clamping (important)	Clamping
Mousetrap board	Support	Support			Support	
Bait					Notice (important)	
Mouse				Mobile		
Pet				Mobile		

Resource analysis: we analyze the resources of the system and the supersystem, and many solutions can get good solutions through resource analysis. Using existing resources, the solutions are often simpler and easier to realize. Resources are generally divided into matter, space, energy field, function, information, time and so on. It is recommended that good solutions be documented during resource analysis.

Table 3

Resource Analysis

Resource Type	Useful resources
Substance	Trigger mechanism, clamping mechanism, mousetrap, bait, mouse, pet, person, house
Field	Gravity field, magnetic field, light field, thermal field, electric field, chemical field, gas field, mechanical field

Features	Support, clamping
Space	House space, area of mousetrap
Time	At night
Information	Bait information

2.3.4 Functional model analysis [5] : we conducted functional analysis of the system and the supersystem.

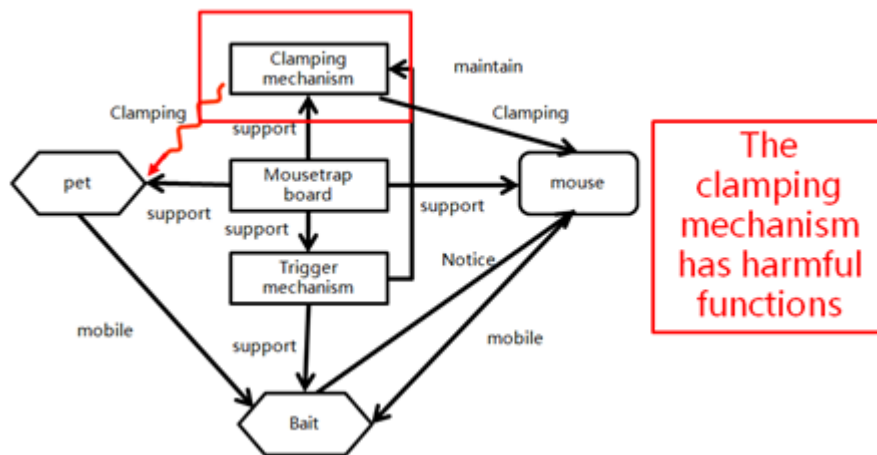


Fig. 5. Functional model analysis

2.3.5 identify problem areas and components:

Cutting analysis [3] :

The clamping mechanism has harmful functions in the system, so cutting is preferred. When confronted with a problem function or component, the general thinking is how to improve it. For example, the heat emitted by incandescent lamps will cause the room temperature to rise. The general direction is to reduce its heat or install air conditioning to change the room temperature. This tends to be modest and costly. What would we get if we tried to cut out incandescent bulbs that are hot? It was easy to think of a non-heating alternative, so leds were invented. It not only solves the problem of incandescent lamp heating, but also reduces the cost. That way, the problem is solved more thoroughly than it is compromised. Therefore, when encountering problematic functions or components, give priority to direct tailoring, so as to achieve a higher level of innovation and more thorough problem solving.

- (1) apply the cutting rule A: if the functional object does not exist, the functional carrier can be cut off.

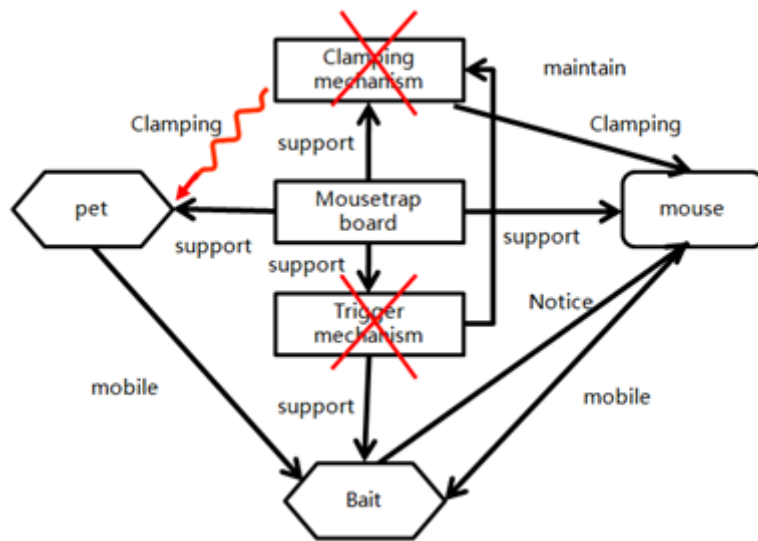


Fig. 6. Crop analysis chart

2.3.6 Function model after tailoring:

After cutting: after cutting, the system is simplified, and its components mainly include mouse, mousetrap and bait.

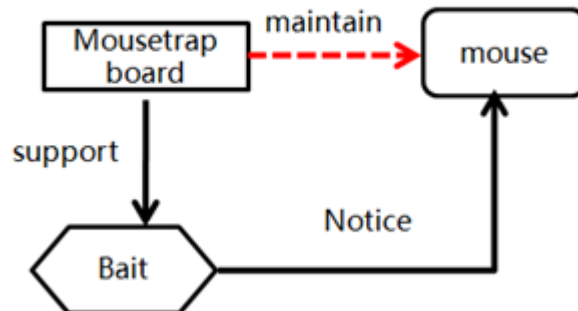


Fig. 7. Cropped function model diagram

2.3.7 Establishment of field model:

After the system is clipped, as shown in figure 7, the mouse catching board keeps the mouse function insufficient, which is converted into the insufficient field model.

Establish the object field model: through the previous component analysis, interaction analysis and tailoring analysis, establish the object field model for the technical system, as shown in the following figure:

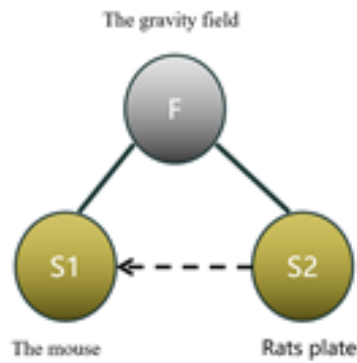


Fig. 8. Establish the object field model

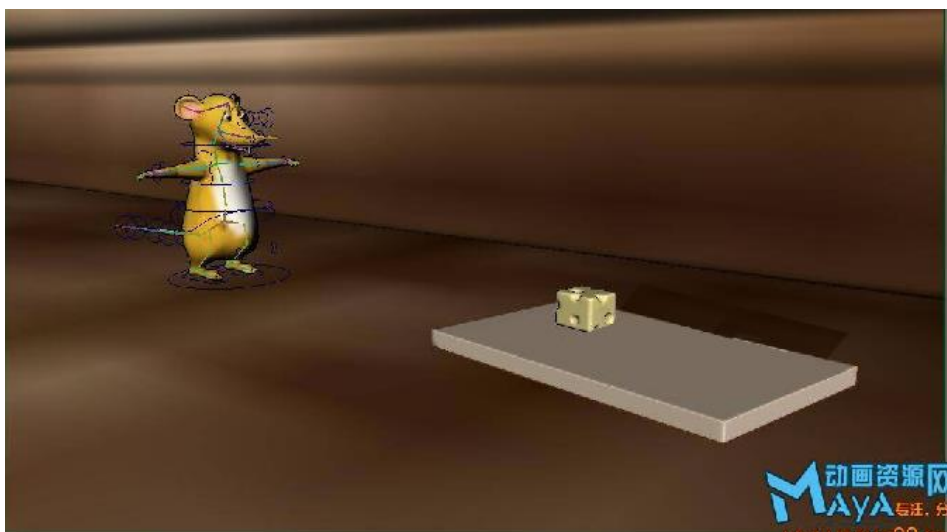


Fig. 9. Schematic diagram of system after cutting

2.3.8 Determine the corresponding standard solution;

The second kind of standard solution: the enhanced field model, the detailed content refers to the related literature, this paper omitted.

2.3.9 Establish new field model [6];

Standard solution: S2.1.2 two-object field model was adopted

The existing system is not sufficiently useful and needs to be improved, but does not allow the introduction of new components or substances, which can be solved by adding a second field. Consider fields that are cheap, accessible, and controllable, such as friction. Below, friction F2 is introduced into the technical system to establish a new technical system, as shown in the figure below.

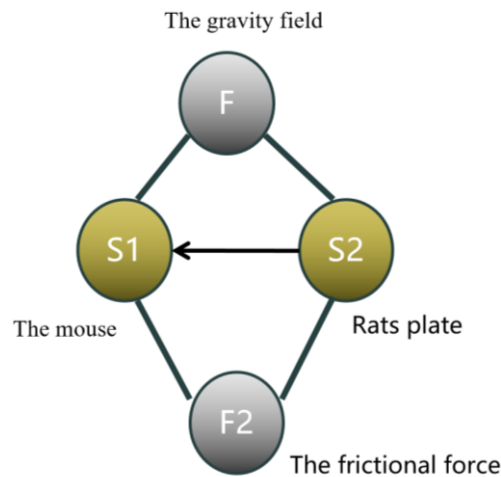


Fig. 10. Establish a new field model

2.3.10 generate specific schemes:

The trap board is made into a box, one side of which is beveled and very smooth, so that the mouse is trapped inside the box. This is shown below.

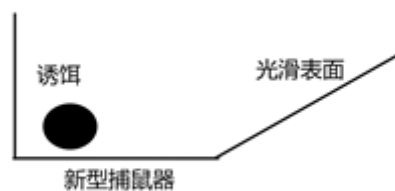


Fig. 11. A new scheme

3 Summary

This paper puts forward the view of combining functional analysis and object field model, that is, incomplete, excessive, insufficient and harmful functions after functional analysis or function cutting are directly analyzed and solved by corresponding object field model, with the purpose of improving the efficiency of solving problems. The purpose of this paper is to share my experience in learning TRIZ on the basis of previous knowledge and experience, hoping to give you a little bit of inspiration. My experience is limited, the paper will inevitably have mistakes, welcome everyone to criticize and correct, thank you!

References

1. Sun Yongwei [Sergey Ikovento]. TRIZ: The golden key to open the door to innovation. Beijing: Science Press, 2015.
2. Zhao Min. TRIZ advanced and actual combat: the invention method of Avenue to Jane. Beijing: Mechanical Industry Press, 2016.

3. Lu Ximei, Zhang Fuying, Zhang Qingqing. Product Innovation Design Based on TRIZ Theory and Functional Analysis [J]. Mechanical Design and Manufacturing. 2010 (12)
4. Yan Susu, Ma Lizhong TRIZ theory mechanical innovation design engineering training course. Peking University Press. 2011.
5. Tan Runhua. Innovative design: TRIZ invention problem solving theory [M]. Beijing: Mechanical Industry Press, 2002.
6. Zhao Xinjun. Technological Innovation Theory (TRIZ) and Applications [M]. Beijing: Chemical Industry Press, 2004.
7. Yang Qingliang. The invention was born in this way - the full contact of TRIZ theory [M]. Beijing: Mechanical Industry Press, 2009.
8. Genrich Altshuller. TRIZ's theory and method of creative problem solving. Southwest Jiaotong University Press, 2004.

Communicating Author: sxf31307@126.com

TRIZfest 2019

September 11-14, 2019. Heilbronn, Germany

TECHNOLOGY SCOUTING IN CHEMISTRY: ROADMAP AND CASE STUDIES

Oleg Abramov^a, Pavel Fimin^a, Evgenia Smirnova^a

^a*Algorithm Ltd., 16 Ruzovskaya Street, St. Petersburg, 190013, Russia*

Paper Classification:

- TRIZ-related methods and tools development
- Case study

Abstract

Technology scouting, one of the elements in modern technology management systems, is a method used for technology forecasting and in competitive intelligence. In TRIZ-consulting, technology scouting is typically performed when it is necessary (1) to determine the state of the art in technologies utilized by the client, (2) to identify a new technology for manufacturing some new product, or (3) to find the most appropriate existing technology that the client can utilize for producing an existing product. The main TRIZ tool currently used for technology scouting is Function-Oriented Search (FOS), which allows identifying new technologies from the remote areas of engineering that can be used to produce a specific new product. Although generally an excellent tool, FOS does not always help in the identification of existing technologies for producing an existing product. This is especially true for the chemical industry because in this industry it is difficult to adopt technologies from remote areas such as electronics, aerospace or mechanical engineering. Based on their practical experience in TRIZ consulting in the chemical industry, the authors have developed a roadmap for identifying the most appropriate existing technologies for a client to produce a desired chemical product. The roadmap involves such modern TRIZ tools as the analysis of Main Parameters of Value (MPV analysis) and screening based on the Quantum-Economic Analysis (QEA-screening). The roadmap is applicable not only in the chemical industry, but in other industries as well. Two brief case studies involving chemicals are presented to illustrate the use of the roadmap.

Keywords: *function-oriented search, FOS, main parameters of value, MPV analysis, technology scouting, TRIZ, voice of the product, VOP, Quantum-Economic Analysis, QEA-screening.*

2 Introduction

Technology scouting, which is an essential element of technology management, is also a method used for technology forecasting and in competitive intelligence [1].

Technology scouting companies divide their activity into several categories. For example, CRIT mentions six types of technology scouting that address different client needs [2]:

1. State of the Art identification. This is a scouting research aimed at revealing a complete picture of a specific technology context or a comparison between best technologies available.

2. Problem Solving. This type of scouting aims to solve a specific technological problem.
3. Identification of Suppliers/Competencies/Key Players.
4. Patent Analysis that reveals the patenting activity of selected competitors or of a specific technology sector.
5. Technology Foresight involves a survey of the major trends of technology sectors in order to identify the most promising or suitable available technologies in the sector.
6. Quick Search yields a collection of technical and scientific documentation on technologies of interest.

In TRIZ-consulting, all these technology-scouting activities, especially the first four items, are in high demand. Most frequently, TRIZ technology scouting projects include all of these four activities because

- Problem Solving requires a good understanding of the State of the Art;
- Clients typically need to know who the Suppliers and Key Players in the area of interest are;
- Clients want to make sure that they have the Freedom to Operate (FTO) with the solutions that TRIZ-consultants propose, and this requires a Patent Analysis.

TRIZ has already received some recognition as a useful methodology even among non-TRIZ technology scouts. For example, Woolford et al. [3] say: “A useful methodology in this scouting role is TRIZ. Specifically the approach of taking a system apart (virtually) and defining the cause and the manifestation of a problem can be really helpful in establishing where to work on solutions. This does not only work for engineering problems but can also work for foodstuffs and even organisational challenges.”

Professional TRIZ-consultants, for example GEN TRIZ [4], claim that the main TRIZ tool for technology scouting projects is Function-Oriented Search (FOS), introduced by Litvin [5] in order to identify solutions that can be adopted from remote areas of engineering.

Despite being an excellent tool, FOS does not always help in the identification of the most appropriate existing technologies for producing an existing product. For example, FOS is not very useful when the technology for producing a product should or can only be found in the same industry to which the product belongs. This is a typical situation in, for example, the chemical industry when the objective is to find the most appropriate technology for the synthesis of some chemical product. In this case, the relevant technologies simply do not exist in remote areas such as electronics or mechanical engineering.

Moreover, even when FOS is applicable to technology scouting, it only yields a set of technologies that could be adopted from the remote areas, but does not recommend which of those technologies are the most appropriate for the client.

In order to address these limitations, the authors summarized their practical experience in TRIZ consulting in the chemical industry and developed a FOS-based roadmap for identifying existing technologies that are most suitable for a particular client in order to produce a specific chemical product. This roadmap is applicable not only in the chemical industry, but in other industries as well. Two brief case studies related to the synthesis of heat stabilizers and lubricants for polyvinyl chloride (PVC) are presented to illustrate the use of the roadmap.

3 Method: TRIZ tools utilized

In addition to FOS, the roadmap that we propose for technology scouting involves several other modern TRIZ tools. They are:

- Main Parameters of Value (MPV) analysis summarized by Litvin [6]. This analysis helps to clarify critical parameters (MPVs) that the client is looking for.
- Voice of the product (VOP) described by Abramov [7, 8]. VOP makes it possible to identify MPVs that the technology may offer to the client. Significantly, in technology scouting the technology plays the role of product; so, in fact, we are talking here about ‘voice of the technology’. However, for consistency we will use the term VOP in this paper.
- A screening tool utilizing Quantum Economic Analysis (QEA) introduced by Abramov et al. [9, 10] (further in this paper referred to as QEA-screening). With this tool, individual technologies or even groups of technologies that are unpromising for the client in terms of business can be rejected.

4 Results

The resulting roadmap that the authors suggest for technology scouting projects is shown in Fig. 1.

The roadmap shown in Fig. 1 assumes that the technology of interest has already been selected, which is usually the case in TRIZ consulting practice.

As can be seen from Fig. 1, the roadmap includes several screening steps that involve VOP, QEA-screening and technical criteria for rejecting technologies that are less promising for a specific client. This makes technology scouting fast and reliable because the approach we propose yields the technologies that are promising not only in terms of performance, but in terms of the client’s business as well.

The authors have successfully applied all parts of this roadmap in several technology scouting projects. Two brief case studies are given below.

4.1 Case Study 1: Heat Stabilizers for PVC

In this project, the client was a medium-sized company producing organotin stabilizers for preventing the thermal degradation of polyvinyl chlorides (PVC). Among organotin heat stabilizers, butyltin and octyltin derivatives are the most commonly applied, especially if colorlessness and transparency of the finished product are required [11]. Recently, other alkyltin compounds, mono- and disubstituted methyltins, have made their appearance on the heat stabilizer market due to their cost-effectiveness and heat resistance property [12]. Our client was looking for a production process that would obtain a mixture of monomethyltin trichloride (MMTC) and dimethyltin dichloride (DMTC) on a commercial scale. The latter is used in the preparation of methyltin stabilizers by a relatively straightforward reaction with an appropriate mercaptide [13].

The relation between two components in the mixture had to be varied over a wide range. As constraints, using superatmospheric pressure and emission of toxic by-products during the production process were unacceptable.

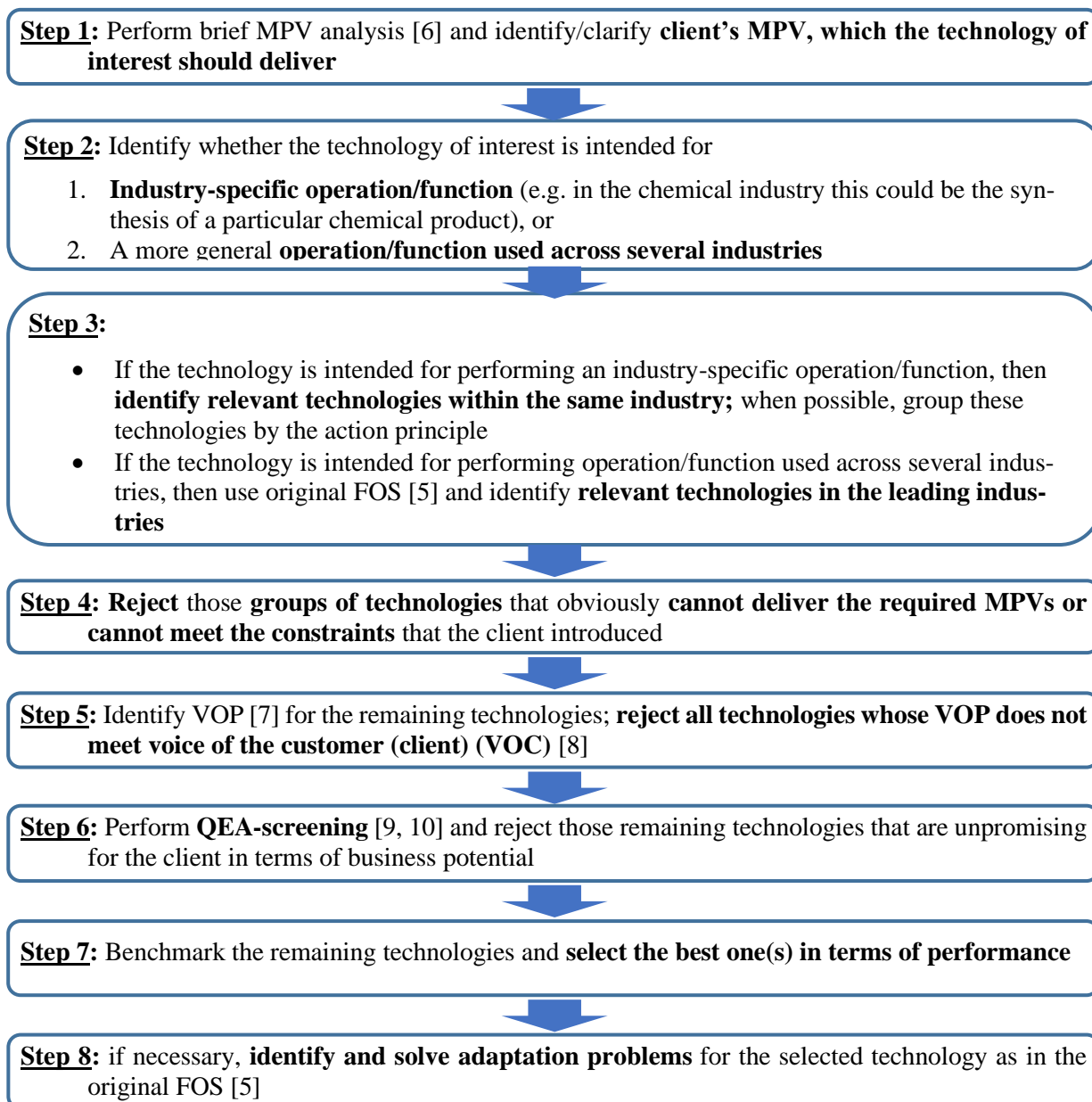


Fig. 1. TRIZ roadmap for technology scouting

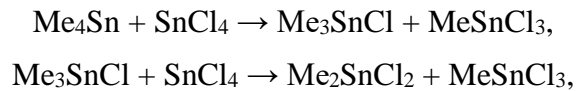
Rather than comparing more than 30 industrial technologies for making MMTC and DMTC in scientific and patent literature, we first identified common chemical routes for synthesizing the required compounds. A brief customer-oriented MPV analysis was conducted for each route to outline conceptual directions for scouting. As a result, the following features were revealed:

1. At atmospheric pressure, only redistribution reactions (for example, between tetramethyltin and tin tetrachloride) make it possible to obtain DMTC and MMTC [14]. However, it is necessary to convert the moiety of tin tetrachloride into tetramethyltin beforehand [15].

2. Direct synthesis of DMTC from tin and methyl chloride does not require an intermediate step to obtain tetramethyltin. However, sufficiently high pressure (at least, 10 atmospheres) is necessary to accomplish the reaction [16]. The direct method for obtaining MMTC [17] causes similar difficulties.

Taking into account the project constraints, we did not consider two dozen direct synthesis methods and further focused on only the technologies based on redistribution reactions.

In the VOP analysis of the remaining technologies, we gave a low score to the classic redistribution method originally developed by Kocheshkov [18] and later systematically investigated by Neumann [19]. Using this method does not result in high purity MMTC because at mild conditions (i.e. relatively low pressure and temperature) only the following two stages of the process complete within a reasonably short time:



However, the third stage of the process:



does not proceed.

Under these conditions, about one-third of DMTC remains in the mixture. Meanwhile, MMTC is essentially less toxic than DMTC [20]; therefore, it is reasonable to expect that in the foreseeable future, only compositions having a very high MMTC content will be in demand in large volumes while the formulations with enhanced DMTC content will be forbidden.

Thereby, modified redistribution methods that initiate the catalytic conversion of DMTC into MMTC [21], which were preceded by the synthesis of DMTC from tetramethyltin and tin tetrachloride, were recognized to be of primary interest¹.

4.2 Case Study 2: High Performance Biolubricant

Although chemical stabilizers significantly improve PVC's inherently poor thermal stability, lubricants are also necessary to process unplasticized PVC. During the processing of PVC, internal lubricants decrease friction occurring between the molecular chains of a polymer and thus lower the melt viscosity, while external lubricants reduce wall adhesion between PVC and metal surfaces [23]. Nowadays, the utilization of renewable raw materials is considered to be a "green chemistry" approach that can contribute to sustainable development [24]. On the lubricant market for PVC, sucrose polyesters made from sugarcane and vegetable oils are potentially capable of replacing conventional petrochemical products [25]. Procter & Gamble (P&G) developed an efficient process for manufacturing such compounds under the trademark of SEFOSE [26]. Therefore, our client, a medium-sized chemical company producing additives for PVC, asked us to identify technology for obtaining sucrose octastearate that would not violate valid P&G's patent [27].

¹ The second conversion technology suggests the application of a polar solvent to facilitate effective ion exchange between DMTC and tin tetrachloride [22]. However, VOP for this technology did not meet VOC because the process requires large quantities of solvent and the cost of freeing MMTC from the complex formed in the course of the reaction is unaffordably high.

The quick MPV analysis [6], which we performed for the process of sucrose polyester synthesis, showed that, to achieve high performance, it is necessary to provide a good mass exchange between two immiscible phases: polar sucrose and nonpolar fatty acid methyl esters. In P&G's active patent [27], sparging an inert gas through the liquid mixture is carried out to facilitate effective mass transfer between the reagents. Therefore, we had to find alternative technologies for mixing the substances.

Original FOS [5] revealed that biodiesel production is the leading area of industry where the generalized function "to mix liquids" is implemented to mix immiscible vegetable oil triglycerides and a monobasic alcohol [28].

From the list of relevant technologies that we identified, those that have not yet been applied on a commercial scale were excluded (they are not mentioned here).

As a result, the following methods were found to intensify the mixing process [29]:

- Ultrasonic cavitation;
- Hydrodynamic cavitation;
- Static mixing;
- Rotor-stator mixing.

QEA-screening [9, 10] revealed that for a medium-sized company, such as our client, all of these methods are promising in short to mid-term prospective. The benchmarking of screened technologies showed that the ultrasonic cavitation method is the best in terms of performance.

5 Conclusions

This paper represents a research in progress and the roadmap for technology scouting presented here, although it was useful in actual TRIZ-consulting projects that the authors performed for companies in the chemical industry, cannot be claimed yet as a universal roadmap that works equally well in all industries. Its versatility remains to be tested in practice.

On the other hand, the roadmap does cover an important and in-demand practical case when a client wants to identify the most appropriate existing technology for producing an existing product that may be new to the client but already produced by competitors.

As compared to the original FOS [5], the proposed roadmap provides

1. Much more specific and detailed recommendations for most steps, which saves time and resources in the project;
2. Higher value of the results because it rejects unpromising technologies that either do not meet VOP or unlikely to be commercialized by the client.

Acknowledgements

The authors would like to thank Deborah Abramov, for her helpful comments and for editing this paper.

References

1. "Technology scouting." (2018) Wikipedia: The Free Encyclopedia, Wikimedia Foundation Inc. Available: https://en.wikipedia.org/wiki/Technology_scouting, accessed April 3, 2019.

2. CRIT S.R.L. "Technology scouting". CRIT Web site. <https://www.crit-research.it/en/technology-scouting/>, accessed April 17, 2019.
3. Woolford S., Peters J., Hogan M. "Open innovation and technology scouting". *New Food Magazine*, May 13, 2011. [Online]. Available: <https://www.newfoodmagazine.com/article/4456/open-innovation-and-technology-scouting/>, accessed April 3, 2019.
4. GEN TRIZ, LLC. "Case Study: Technology Scouting." GEN TRIZ Web site. <https://www.gen-triz.com/case-study-technology-scouting>, accessed April 17, 2019.
5. Litvin S.S. "New TRIZ-Based tool Function-Oriented Search (FOS)". *The TRIZ Journal*, August 2005. [Online]. Available: <http://www.triz-journal.com/new-triz-based-tool-function-oriented-search-fos/>, accessed March 20, 2019.
6. Litvin S.S. "Main Parameters of Value: TRIZ-based tool connecting business challenges to technical problems in product/process innovation". 7th Japan TRIZ Symposium, September 9, 2011. Available: [http://www.triz-japan.org/PRESENTATION/sympo2011/Pres-Overseas/EI01eS-Litvin_\(Keynote\)-110817.pdf](http://www.triz-japan.org/PRESENTATION/sympo2011/Pres-Overseas/EI01eS-Litvin_(Keynote)-110817.pdf), accessed March 11, 2019.
7. Abramov O.Y. "Product-oriented MPV analysis to identify Voice of the product". *Proceedings of TRIZfest-2016 Conference, Beijing, People's Republic of China, July 26-28, 2016*, pp. 231-243. Available: <https://matriz.org/wp-content/uploads/2017/01/TRIZfest-2016-Conference-Proceedings.pdf>, accessed March 11, 2019.
8. Abramov O.Y. "'Voice of the Product' to supplement 'Voice of the Customer'". *The TRIZ Journal*, Jan 11, 2017. Available: <https://triz-journal.com/voice-of-the-product-to-supplement-voice-of-the-customer/>, accessed March 11, 2019.
9. Abramov O., Markosov S., Medvedev A. "Experimental validation of Quantum-Economic Analysis (QEA) as a screening tool for new product development." In: Koziolok S., Chechurin L., Collan M. (eds.) *Advances and Impacts of the Theory of Inventive Problem Solving*. Springer, Cham, pp. 17-25, First online 30 November 2018.
10. Abramov O.Y. "Generating new product ideas with TRIZ-derived 'Voice of the Product' and Quantum-Economic Analysis (QEA)". *Journal of the European TRIZ Association, IN-NOVATOR*, ISSN 1866-4180, 02/2017, vol. 04, pp. 80-87. Available: <http://www.etria.eu/innovator/ETRIAJournal2017vol04.pdf>, accessed April 03, 2019.
11. Piver W.T. "Organotin compounds: industrial applications and biological investigation", *Environmental Health Perspectives*, June 1973, Issue 4, pp. 61-79. Available: <https://www.ncbi.nlm.nih.gov/pmc/articles/PMC1474848/pdf/envhper00501-0066.pdf>, assessed April 17, 2019.
12. "Global organic PVC stabilizers market professional survey report", Published by QY Research, July 2018. – 111 pages. Available: <https://www.researchmoz.us/global-organic-pvc-stabilizers-market-professional-survey-report-2018-report.html>, assessed April 17, 2019.
13. Spiegelman G., Liauw K.-L. "Preparation of mixtures of methyltin trichloride and dimethyltin dichloride from stannic chloride and dimethyltin dichloride without catalyst and conversion to mixed methyltin mercaptide stabilizers", US Patent 4,434,102. Publication date: February 28, 1984.
14. Van den Berghe E.V., Van der Kellen G.P. "Alkyl redistribution reactions of (CH₃)_nSn_{4-n} compounds (X = Cl, Br, I)", *Journal of Organometallic Chemistry*, 1966, Vol. 6, Issue 5, pp. 522-527.
15. Thoonen S.H.L., Deelman B.-J., Van Koten G. "Synthetic aspects of tetraorganotins and organotin(IV) Halides", *Journal of Organometallic Chemistry*, 2004, Vol. 689, Issue 13, pp. 2145-2157.
16. Witman R.C., Kugele T.G. "Preparation of dimethyltin dichloride", US Patent 3,857,868. Publication date: December 31, 1974.

17. Matsuda S., Kudara H. "Method for producing monoalkyltin trihalides", US Patent 4,046,791. Publication date: September 6, 1977.
18. Kocheshkov K.A., Zemlyanskiy N.N., Sheverdina N.I., Panov E.M. "Methods of organoelement chemistry. Germanium, tin, lead". Moscow, Nauka, 1968, pp. 329-375. (In Russian).
19. Neumann W.P. "Substituent exchange equilibria on germanium, tin, and lead", Annals of the New York Academy of Sciences, 1969, Vol. 159, Issue 1, pp. 56-72.
20. Dobson S., Howe P.D, Floyd P. "Mono- and disubstituted methyltin, butyltin, and octyltin compounds". World Health Organization, 2006. ISSN 1020-6167. Available: https://apps.who.int/iris/bitstream/handle/10665/43549/9241530731_eng.pdf, assessed April 20, 2019.
21. Kugele T.G., Parker D.H. "Catalyzed redistribution of alkyltin halides", US Patent 3,862,198. Publication date: January 21, 1975.
22. Langer H.G. "Synthesis of organometallic halides by redistribution", US Patent 3,454,610. Publication date: July 8, 1969.
23. Fahey T.E. "Classification of lubricants for PVC by compaction testing", Journal of Vinyl Technology, 1982, Vol. 4, Issue 3, pp. 115-119.
24. Pan X., Sengupta P., Webster D.C. "Novel biobased epoxy compounds: epoxidized sucrose esters of fatty acids", Green Chemistry, 2011, Vol. 13, Issue 4, pp. 965-975.
25. Galembeck F., Macedo G.A., Csordas Y. "Chemicals from sugarcane". In: Letcher T.M., Scott J.L. (eds.) Materials for a Sustainable Future, Royal Society of Chemistry, 2012, pp. 259-287.
26. Ballantyne C. "New chemicals for ecofriendly paints and lubricants". Available: <https://blogs.scientificamerican.com/news-blog/new-chemicals-for-eco-friendly-pain-2009-04-13>, assessed April 24, 2019.
27. Corrigan P.J. "Synthesis of polyol fatty acid polyesters", US Patent 6,620,952. Publication date: September 16, 2003.
28. Van Gerpen J. "Biodiesel processing and production", Fuel Processing Technology, 2005, Vol. 86, Issue 10, pp. 1097-1107.
29. Stankiewicz A. "Energy matters: alternative sources and forms of energy for intensification of chemical and biochemical processes", Chemical Engineering Research and Design, 2006, Vol. 84, Issue 7, pp. 511-521.

Communication

Communicating Author: Oleg.Abramov@algo-spb.com

TRIZfest 2019

September 11-14, 2019. Heilbronn, Germany

THE 3RD EUROPEAN REMOTE TRIZ WORKSHOP

John Cooke^a, Christoph Dobrusskin^b, Pascal Sire^c

^a*CoCatalyst Limited, Farnborough, UK - john@cocatalyst.com*

^b*Philips MCC, 5656 AE Eindhoven, The Netherlands*

^c*cinnoppie, Strasbourg, France - pascal.sire@innoppie.com*

Paper Classification:

- Educational methods and experiences

Abstract

The 3rd European Remote TRIZ Workshop is due to take place on June 14th 2019. The workshop sets out to challenge groups of TRIZ practitioners from a wide range of backgrounds and companies with a common problem. The purpose of the event is to enable participants to learn from each other as they apply TRIZ methods and report their findings.

While previous similar workshops have been well-received, they have also yielded some important learnings. This paper describes how the design, scope and challenge statement for this year's event have been modified in response.

Keywords: *TRIZ, Workshop, Remote, Case Study.*

1 Introduction

During the second Remote TRIZ Workshop [1], run in January 2017, participating teams were encouraged to address the problem of water scarcity. The workshop was generally well-received with people taking part especially valuing the opportunity to learn from each other, but the problem topic itself was the subject of both positive and negative feedback. Generally using TRIZ as a problem solving tool is becoming more widely established, both in businesses as well as in education [2, 3] While a few participants felt that there was significant worth in addressing the water scarcity issue, others commented that the open nature of the problem meant that too much time had to be spent on analysis rather than on arriving at solutions, leading to superficial problem solving.

Also, lessons that the authors gained from other projects and work in education [4, 5, 6] were taken into account.

The design of the third edition of the Remote TRIZ Workshop aims to address this issue while enabling teams to select and address problems they still perceive to be worth solving.

The feedback from previous workshops highlighted that the choice of the problem topic is a critical element for a successful workshop. Choosing a problem is already difficult for a number of reasons:

- For example, as a number of multinational companies are likely to participate, the topic has to be in a non-competitive field.
- The problem should be easy to understand and not be too technical to encourage the involvement of non-technical participants or even students.
- As previously discussed, the problem should give the teams scope to choose to work on something they feel is worthwhile.

2 Workshop Set-up

Some time in advance, the problem description is sent to the representatives of the different participating groups. This enables them to do some preliminary analysis work if they think this is necessary. The following table shows the agenda of the day.

The formula used is, in principle, easy:

1. In preparatory sessions a problem is selected that is wide enough for everyone to be interesting to work on.
2. In a morning session, lasting a maximum of one hour, the problem is explained to all participating groups via internet communication means. This enables the exchange of spoken word but also of drawings, sketches and the like. At this point participants can ask questions for clarification.
3. For the rest of the day, until 3pm, participants work on the problem in their respective groups using a variety of TRIZ and supporting tools to frame, analyse and solve the given problem. By 3pm the groups should have uploaded a small presentation file onto a common SharePoint.
4. From 3pm onwards each group successively presents both the approach they used as well as summary of the resulting ideas. Other groups may ask questions for clarification.

Table 1, The agenda of the day

Start time	End time	Topic
09:00	10:00	Briefing on the Problem
10:00	15:00	Work on the problem
15:00	17:00	Debriefing, 10 minutes per group

3 Case Description

In contrast to the previous workshop a more specific topic was chosen. The underlying problem, that of plastic pollution stays the same, however within the myriad different angles to view that problem a very specific one, and one that many people can relate to, has been chosen. It relates to an egg-shaped chocolate treat aimed predominantly at children. The chocolate treat consists

partially of brown coloured chocolate and partially of some white chocolate (or a similar milk-powder based compound).

The hollow chocolate egg contains a yellow plastic container that in its turn contains a plastic toy and a small printed leaflet. Most often the plastic toy is consisting of several parts and has to be assembled by the user, see Figure 1.



Fig.1. The unpacking of a chocolate egg with the plastic toy

Because of the small parts the item is not recommended for children under 3 years of age.

By choosing a specific product within a larger problem area, the creative work can be focused. Furthermore, the product in question is well known – at least in Europe and the US. And finally it can be consumed to create extra energy during the workshop should the need arise.

3.1 The problem

With the recent focus on plastic waste, from the “plastic soup” in the oceans to subsequent microplastics entering the food-chain, it seems opportune to improve a product like this. The overall project aim is thus to find environmentally friendly alternatives for the plastic parts that are included in this toy.

3.2 *Sub-problems*

Aspects of the problem that could be addressed include:

- The elimination of the plastic toy contained in the egg, but keeping the attraction to potential buyers
- The elimination of the yellow plastic egg that is needed for hygienic reasons and to separate sharp parts from the inside of the egg as well as protecting the plastic parts when the chocolate egg is opened.
- Eliminating the paper that is needed for regulatory reasons, but keeping the information
- Reducing or eliminating the aluminium packaging
- Improvements around the manufacturing process
- Concerns about the health impact of sugars that are found in chocolate and sweets abound, so finding an alternative without sugars may be prudent

This information is contained in a problem briefing document which also contains further information to support participants in their problem-solving work as detailed below. As no information was available from the manufacturer, assumptions were made about the production process, the required chocolate properties and the associated manufacturing costings, which are shown below

3.3 *The manufacturing process*

A simplified manufacturing process contains the following steps:

1. Molten chocolate is prepared
2. Milk chocolate and white chocolate
3. Half-form concave egg-shaped molds are filled with milk chocolate and spun to achieve an even wall thickness
4. Molds are cooled
5. White chocolate is added into the pre-filled molds and the same process is repeated
6. The toy is inserted into one egg half
7. The edges of one chocolate egg half are heated and locally melted
8. The two egg halves are brought together and sealed (the melted chocolate solidifies)
9. The complete egg is wrapped

A schematic production process flow is shown in Figure 2 below:

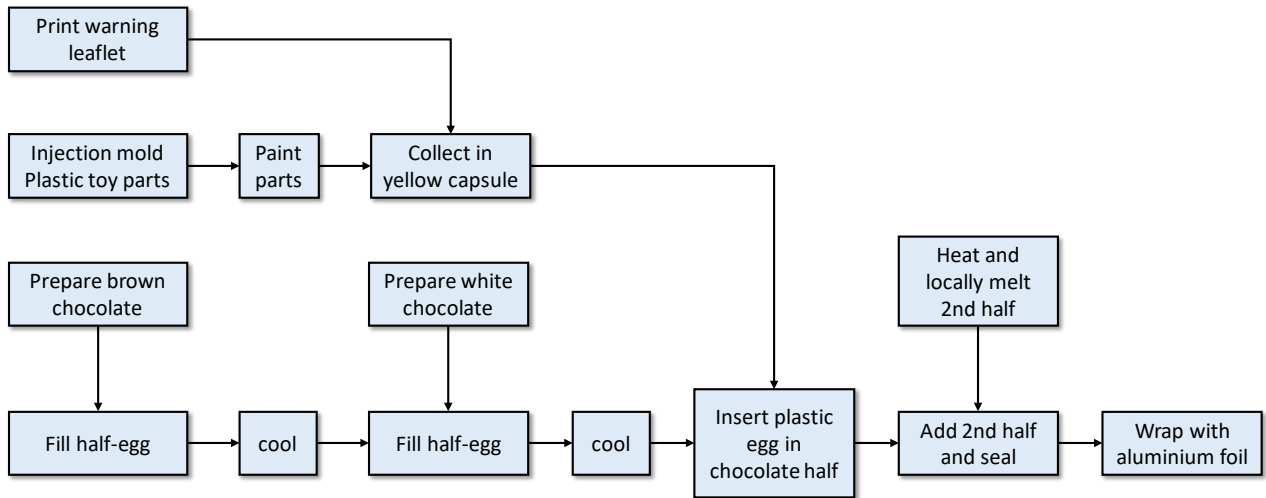


Fig. 2, A schematic production process flow for making the chocolate egg

3.4 Important characteristics of the chocolate

Chocolate tempering:

It is important to temper the chocolate correctly (i.e. cool the chocolate in a specific way) before using the mould. Tempering affects the crystalline structure of the chocolate, the texture of the chocolate and enables the chocolate to resist blooming (whitening of the chocolate and smearing of objects inside the egg if it gets too hot).

Chocolate viscosity:

Chocolate is a non-Newtonian fluid (i.e. viscosity varies with shear rate). The chocolate needs to flow in the right way to fill the mould and produce an even wall section.

Chocolate melting point:

Chocolate melts over a range of temperatures between 26°C and 34°C.

3.5 Estimated costs

Cost estimates have been prepared for all the materials and manufacturing steps required to prepare the egg – see table 2 below. While the costs are likely over-estimated, they nevertheless provide a starting point for investigation.

Table 2.

An overview of the cost items

Item	Material / unit	Weight	Cost	Tooling cost
yellow capsule	Polypropylene	4 gram	0,011	30000
toy1 (green)	unknown material	1,7 gram	0,014	10000
toy2 (owl)	unknown material	3 gram	0,043	20000
placing eyes on owl	paint		0,05	
toy3 (carton)	cardboard		0,05	
warning leaflet paper	paper		0,05	
manufacturing /assembly		20 sec	0,06	
chocolate		20 gram	0,10	
alu foil			0,05	
wrapping / packaging			0,05	
subtotal			0,47	
overhead	10%		0,047	
profit	10%		0,052	
total			0,57	

3.6 Further analysis

Participants may wish to do further analysis to gain a good understanding of the problem situation. Such analysis may be done, for example, by searching for any consumer feedback available for the described products [7], by searching for patents that may describe aspects of the production of products such as the described one [8], or by investigating the extend of the problem of plastic pollution [9].

3.7 Presentation format

A presentation format will be provided to all participating groups. This gives, on one hand a guideline to the participants what is expected from them, and on the other hand, as all will use the same presentation structure, it will make it easier to compare results:

1. The initial slide will record details of the participating group.
2. The second slide (or slides) will record the TRIZ analysis tools that were employed. Which ones were used? In which order? What were the insights gained?
3. The third slide (or slides) will record the TRIZ problem solving tools used. Which ones were used; how did they link to the analysis? What were the results?
4. The fourth slide (or slides) is dedicated to explaining the results / suggestions that were achieved.

4 Workshop evaluation

4.1 Evaluation procedure

The workshop will be evaluated in a number of different ways. As the emphasis is, of course, first and foremost on the TRIZ-related aspects, the workshop will be evaluated using the same questionnaire that was used in the 2017 edition.

The Questionnaire will be sent to all participating groups together with the case materials. The purpose of the questionnaire is to gather information on how the participants experienced the workshop and to identify possible improvement opportunities for future workshops.

The questionnaire is simple and enables a quick response. Apart from asking for some details of the respondent, it consists of six questions [10]:

1. On a scale of 0 – 10, how likely are you to recommend this workshop to a (TRIZ-minded) colleague or friend?
2. In your view, what is the most unique feature of the workshop?
3. What are your key learnings / takeaways from the workshop?
4. In your view, what are the key success factors for the workshop?
5. What would you improve?
6. Any other comments you may have.

Furthermore, as one of the authors has contacts with businesses that are intimately concerned with the reduction of the plastic waste problem, an external judge with experience in the field will be involved in commenting on the results achieved. And as the MATRIZ organization has been so kind as to provide support for a price [11] for the best achievements, this judge will also award this price to the or those teams that, in his judgement provided the best result.

5 Workshop guideline

In the paper that explored the last workshop, a guideline for running workshops such as this was given [12]. Based on the insights gained since then the guideline has been updated and is shown below.

Guidelines for setting up a remote TRIZ workshop

#	What	Who	Duration
Before the workshop			
1	Form a small group of interested persons to organize	Organizers	Bi-monthly meetings
2	Determine the participants, how many groups and which groups.	All	-
3	Set date for the workshop in consultation with expected participants	All	-
4	Plan rooms for the groups	Participants	-
5	Determine the problem to be tackled in the workshop	Organizers	1h – 4h
6	Prepare the Analysis and briefing material for the problem	Organizers	4h
7	Define the communication medium	Organizers	-
8	If telecommunication media (skype) is used, set a date for a test-run	Organizers	-
9	If telecommunication media (skype) is used, prepare a shared drive and communicate to all groups	Organizers	-
10	Dump Problem, Analysis and Agenda on shared drive, alternatively send briefing material to groups well in advance	Organizers	-
11	Test-run telecommunication medium	All	1h
On the day of the workshop			
1	Check in	All	½h
2	Present Problem, Q/A	Organizers	1h
3	Work on problem	All	5h
4	Feedback to other groups	All	1h – 2h
After the workshop			
1	Evaluate	All	1h

6 Conclusions

The purpose of this paper has been to share with audience the approach and characteristics of running a workshop for a multitude of different groups. As of the writing of the paper, 17 groups from 9 countries have expressed interest to participate, so from an initial European perspective, the workshop has grown to a global event. It may be worth noting that, for participants in countries that live in a significant different time zone, the organizers will have a briefing session a day or two in advance and the actual work these groups do will be off-line, before the actual

workshop. The presentation of the workshop results, however, will be done for all groups at the same time.

At the time of the presentation of this paper at the *TRIZ Future* conference, the authors will be able to present not only aspects of the workshop such as the type of participants – students, practitioners, experts – the size of the teams, and the way the teams managed themselves, but also the results of the case, the quality of the solutions found, and who won the prizes and why.

References

1. Dobrusskin C. “Report on the 2nd European Remote TRIZ Workshop”. Proceedings of the MATRIZ TRIZfest 2017 International Conference, Krakow, Poland, 2017.
2. I. Belski I., “TRIZ course enhances thinking and problem solving skills of engineering students”. *Procedia Engineering*, vol. 9, pp. 450–460, 2011.
3. Savage, J. "Moving beyond subject boundaries: fourcase studies of cross-curricular pedagogy in secondary schools". *International Journal of Educational Research* 55: 79-88, 2012.
4. Sire, P., G. Haeffelé, et al. “TRIZ as a tool to develop a TRIZ educational method by learning it”. *TRIZ Future Conference*, Lisboa, Portugal, 2012.
5. Prevost E, Bruno G, Guillou Y, Sire P & Conrardy C. “What roles can TRIZ play in Start-up incubators?”. *Global TRIZ Conference 2014*, Seoul, Korea, 2014.
6. Dobrusskin C., Belski A., Belski I. “On the Effectiveness of Systematized Substance-Field Analysis for Idea Generation”. *TRIZ FUTURE CONFERENCE 2014*, Lausanne, Switzerland, 2014.
7. <http://www.sustainabilityguide.co.uk/2018/04/02/kinder-eggs-recyclable/> accessed March 29th, 2019
8. Dogliotti, A. “Method of manufacture of hollow chocolate articles”, United States Patent # 3,961,089, 1973
9. “Changing the way we use plastics”, European Union, Publications Office, ISBN 978-92-79-77508-6, 2018.
10. Dobrusskin C. “Report on the 2nd European Remote TRIZ Workshop”. Proceedings of the MATRIZ TRIZfest 2017 International Conference, Krakow, Poland, 2017.
11. Lyubomirskiy A., Dr. Litvin S., Dr. Ikovenko S., Prof. Dr.-Ing. Thurnes C., Dr. Adunka R., “Trends of Engineering System Evolution (TESE)”. *TRIZ Consulting Group GmbH*, 2018.
12. Dobrusskin C. “Report on the 2nd European Remote TRIZ Workshop”. Proceedings of the MATRIZ TRIZfest 2017 International Conference, Krakow, Poland, 2017.

Communication

Communicating Author: [c.dobruskin@philips.com](mailto:c.dobrusskin@philips.com)

TRIZfest 2019

September 11-14, 2019. Heilbronn, Germany

THE BARCAMP-FORMAT AS A PERFECT SETTING FOR INVENTIVE SITUATIONS – WHAT THE FIRST GERMAN TRIZ BARCAMP TEACHES US ABOUT INNOVATION CHALLENGES

Horst Naehler^a, Barbara Gronauer^b, Tiziana Bertoncelli^c, Thomas Nagel^d

^a*c4pi / TRIZ-Akademie.de, Huenfeld, 36088, Germany*

^b*Strategieinnovation / TRIZ-Akademie.de, Huenfeld, 36088, Germany*

^c*TRIZ-Consulting GmbH, Muenchen, 80796, Germany*

^d*Tom Spike, Berlin, 10437, Germany*

Paper Classification:

- Best practices, business experiences, integration with non-TRIZ methods/tools
- Educational methods and experiences

Abstract

A BarCamp is a user-generated conference that is based on the self-organization of the participants regarding the topics as well as the style of the sessions. In March 2018 the first German TRIZ-BarCamp was held in Fulda with 25 participants from very different backgrounds regarding profession and level of TRIZ knowledge. This resulted in different challenges that reflect typical situations encountered when dealing with inventive problems and innovation tasks, e.g. creating a productive environment in a short period of time or working on complex tasks. The feedback from the participants and the observations of the organizers lead to several practical lessons and takeaways that can help navigate through innovation processes.

Keywords: *ideation, facilitation, TRIZ Sessions, creativity, BarCamp*

1 First German TRIZ BarCamp

In March 2018 Barbara Gronauer and Horst Naehler organized the first TRIZ BarCamp in Germany. As accredited TRIZ Trainers and moderators they offer their services under the Trademark of “TRIZ-Akademie.de”. As such they have a longstanding background in facilitating TRIZ-Workshops and giving TRIZ Trainings within a multitude of branches for people with diverse backgrounds and a great variety of expectations targeted at TRIZ as an Innovation Methodology. Tiziana Bertoncelli, beyond her activity as research engineer, gained over 10

years of experience as TRIZ practitioner, trainer and facilitator, with special focus on workshops and creativity sessions in corporate environment for innovation projects, mostly in the electrical engineering field. She presently cooperates with TRIZ Consulting Group GmbH as free-lancer and is an employee of Danfoss Silicon Power GmbH.

Thomas Nagel is working as an innovation consultant and promoter of product- and technology innovation. For more than 20 years he is actively applying and teaching methods for product-development, manufacturing, product- and process-innovation and Lean Six Sigma.

Looking at the status quo of conferences on the topic of TRIZ they wanted to offer a new, open platform where participants themselves could dictate the topics and design their “own” conference on the spot, instead of listening to pre-determined speakers as a more or less passive crowd. Logically, the BarCamp format was the ideal framework for such an event.

The TRIZ-BarCamp followed the internationally accepted format spread by the Barcamp International Network. The origins of the BarCamp format goes back to the year 2005, when an open to the public alternative to a so-called “Foo Camp” (an invitation-only, participant-driven event around technology, web-applications and programming) was organized in Palo Alto, CA. Since then the BarCamp format spread throughout the world, used for open gatherings with no dedicated topic as well as topic- or industry-specific or even company-internal BarCamps [1].

The BarCamp format is based on the participation of the attendees. Unlike traditional conference formats all participants of a BarCamp are organizers, presenters and contributors, reflecting in the saying “At BarCamp there are no spectators, only participants”. Every participant is encouraged to offer their own session - a timeslot during the day - where the participant hosts his/her own topic, question, interest or presentation. At the beginning of a BarCamp the sessions are introduced by the hosts. Participants can then declare their interest in this topic, and a schedule for the day is collectively constructed by all participants together. Typically, the information and experiences at a BarCamp are shared via public web channels like social media and blogs. This is also a paradigm shift to many traditional conferences where recordings are typically forbidden.

1.1 Pre-BarCamp-Challenges

The initial intention for the TRIZ BarCamp was to bring together users of the TRIZ methodology regardless of their “TRIZ-pedigree”. The organizers wanted to establish an open platform where TRIZ users could talk about their most pressing problems, their best successes and their overall experience, questions and usage of TRIZ. Because of the fact that there are so many facets to TRIZ, the organizers did not want to put any restraint on the meeting by choosing “experts” for presentations or only accept TRIZ users from a certain TRIZ-“school”.

However, during the planning process it was obvious that a lot of people with no TRIZ background at all were also interested to participate, and that the BarCamp should be a place to get in touch with the methodology. Therefor an introduction was prepared about what TRIZ is, where it comes from and what its underlying premises are. The different possibilities for reliable and well-founded TRIZ education was also addressed. It was made clear in advance that the BarCamp was not intended to be a preplanned TRIZ training.

1.2 Starting the BarCamp

At the TRIZ BarCamp the session planning consisted of short oral presentations with a call for participants, where the number of people needed, the level of needed TRIZ expertise and the approximated required time were also mentioned. After the introductions, participants declared their interest and willingness to attend the dedicated session that lasted about 45 minutes each.

According to the session planning, the schedule consisted of 3 parallel streams with 11 topics covered. Some topics were combined, e.g. when it was suitable to combine a certain TRIZ-tool with an open problem situation or when two topics were complementary.

	Stream 1	Stream 2	Stream 3
11:00	How to clean the oceans from plastic? (by Pia) TRIZ-Tools used: Ideality, Ideal System, Contradictions (by Tom)		
11:45	Is there an easy introduction to TRIZ? How to get people interested? (by Georg)	How can finance companies (e.g. insurances) develop innovative services? (by Markus)	How can we reach educationally disadvantaged people with TRIZ-thinking? (by Barbara)
12:30	Lunch		
13:30	"The escape of the 'smart little hydrogen-people'" (by Siegfried & Lüder) Thinking about drive concepts of the future (by Norman)	Developing a wearable defibrillator (by Tiziana)	
14:15	How to make it attractive to build quit machines? (by Pia)	How do future lighting concepts look like? (by Henrike)	TRIZ & Open Innovation – How to overcome professional blinds (by Peter)
15:00	Invisible wind generators? (by Barbara)	Combining TRIZ with other strategy-tools (by Udo) TRIZ and Digitization – the gap between consumer technology use and business applications (by Alex)	
15:45	Presentation of Results/Findings, Wrap-up and Feedback		

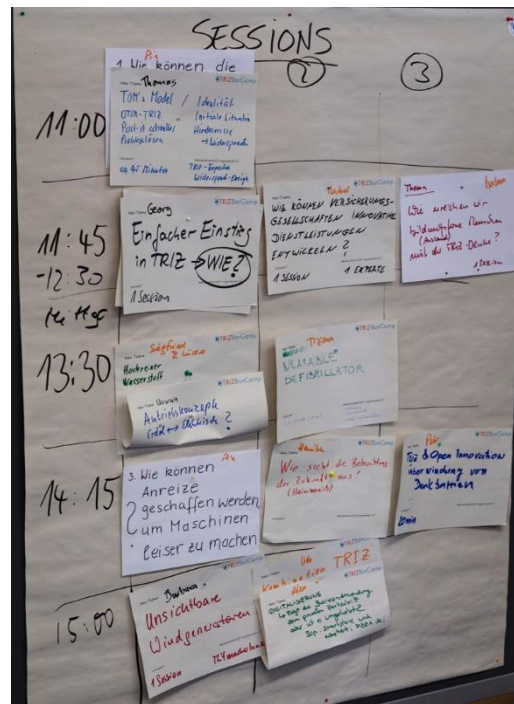


Fig. 1. Building up the schedule

2 Two examples of TRIZ BarCamp-Sessions

To illustrate the typical structure and flow of a BarCamp-session, two topics will be introduced here exemplarily. The examples show that even complex tasks as well as very specific problem situations were tackled in the short timeframes given, and that the TRIZ tools enabled a good facilitation for even “TRIZ-untrained” participants.

The Wearable defibrillator session

The wearable defibrillator topic was introduced explaining which kind of patient need such a device and the issues it poses and selected for a 20-minute session, for which all level of TRIZ expertise were welcome. This kind of device is usually an option for all patients at risk for sudden cardiac arrest for whom the very invasive surgery intervention to implant an internal defibrillator is not viable. The metallic paddles that convey the electrical discharge have to stay attached to the skin for effectiveness of the device, but such a solution presents several problems, i.e. lack of comfort, difficulties in usage for overweight people, skin rash and burns, itching, sleep disturbances. Moreover, the vest be removed to shower or bathe. As a result, many patients stop using it, putting themselves at a very high risk [2, 3, 4]. The listed issues lent themselves naturally to be formulated as physical contradictions and could be very effective to illustrate TRIZ modelling approach for a known technology, to show how powerful TRIZ can be to identify the needed improvement actions.

The team was tasked to identify solutions as effective as the implanted defibrillator, but with a lesser degree of invasiveness; the workshop was kicked off posing no boundary to the kind of ideas and with the statement that ideas were to be released and published afterwards.

Since a very short time was allocated for the creativity session, the TRIZ modelling phase had already been sketched as a pre-work outcome and presented to the participants in the form of handouts. The proposed TRIZ tools were Physical Contradictions (PCs) and Substance-Field

modeling. The PCs were selected because translated naturally the list of problems to solve; Su-Field models were chosen because their visual nature eases a very quick understanding even among people without TRIZ background [5]. A Function Model was also prepared, to serve as an example and guideline if needed. From the modeling perspective, it was interesting how the participants were able to reformulate the proposed physical contradiction, splitting it according to the main function exerted and the operating time as following:

Monitoring Function

Electrodes SHOULD BE attached to the skin

to monitor heart

Electrodes SHOULD NOT BE attached to the skin

not to irritate or damage it

Restart Heartbeat Function

Electrodes SHOULD BE attached to the skin

to convey electrical discharge

Electrodes SHOULD NOT BE attached to the skin

not to irritate, damage or burn it

Fig. 2 reports the Substance-Field model used during the session:

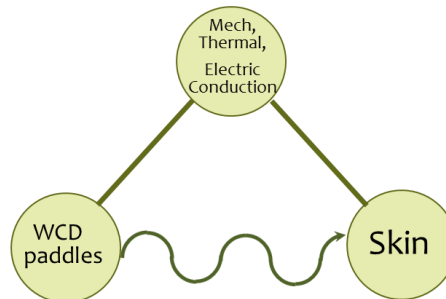


Fig. 2. Substance-field model for a wearable defibrillator

The Function Model was not employed during the session because of its complexity, not compatible with the allocated time.

The generated ideas (~20) were reported on a board (Fig. 3):



Fig. 3. Generated ideas

and organized according to the category of action to be taken, i.e.:

- Modify Vest
- Modify Monitoring
- Minimize battery size for low weight Vest
- Use other fields (not electrical)
- Act on ECG
- Use another substance S3* between pads and skin to improve conductivity – use available body fluids
- Use another substance S3* between pads and skin to improve conductivity – Modified T-shirt

For the last category of ideas even a function model of the solution was generated: in Fig 4 it is shown how to use a patch of special textile just under the electrodes that gets conductive when wet conductive gel is pumped on it.

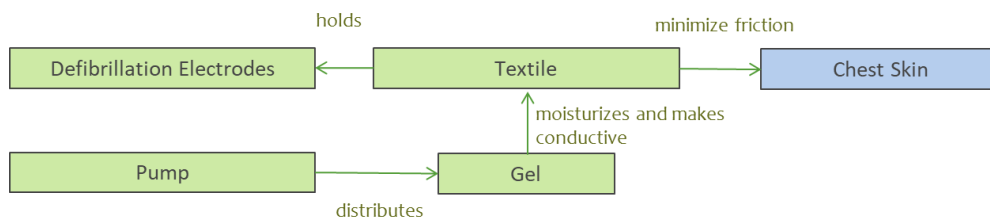


Fig. 4. Function Model of a generated idea

The large number of generated ideas represented a very positive outcome of this session, characterized by a very active engagement of the participants, especially the TRIZ-initiated; non-

TRIZ experts were on the other hand intimidated and could feel engaged only if the model was very simple and visual.

Session: How can plastic waste in oceans be reduced?

The meta-question “how the large amounts of waste in rivers and oceans can be reduced or eliminated” proved to be a very complex and global topic. A cause-effect-chain analysis quickly showed, that the global economic interests of companies and political players in many ways contradict the ecological interests of citizens. Due to the short duration of the session of about 45 minutes and the complex interrelationships of the topic it was clear that a quick and comprehensive solution to comply to sustainability goals.

To get a practical introduction to TRIZ application the participants first gathered negative aspects and harmful effects of plastic waste in oceans – e.g. “dead animals” and “waste on sea-shores and beaches”. Those aspects were then used as starting points to formulate physical and engineering contradictions. Inventive tasks like “how can we bring water to remote areas that have no water supply systems without using plastic bottles/containers”? Several approaches were then briefly discussed – ideas of using grids in rivers or using plastic as resources for construction were quickly mentioned.



Fig. 5. BarCamp Session “Plastic waste in Oceans”

3 Challenges during the BarCamp and recommendations

During the BarCamp the paradigm-shifting nature of the “Unconference”-Format began to show. Although the rules and guidelines of the BarCamp were communicated in advance, it was hard not to let the consumer-mentality gain the upper hand. Self-organization and self-responsibility are not widespread requirements in organizations [source?]. It took some time and repeated encouragement to get participants to offer sessions and actively engage in the process.

Each of the sessions could be seen as short TRIZ sessions, a similar format to what can be utilized in companies when applying TRIZ as a trained user with coworkers who did not have TRIZ training.

In companies/industrial environment usually the participants are already familiar with the problem: this can be seen as an advantage because it speeds up the problem identification phase; on the other hand an established problem among a group of experts entering the session as strong-opinionated people suffers of a strong psychological inertia from the technology point

of view, so specific techniques must be put in place to overcome it. Moreover, in such groups also group dynamics can steer the idea generation.

The spontaneous nature of a Barcamp session totally removes both of these issues; if the working team is very diverse as far as the TRIZ-literacy is concerned, although it is difficult to make the contributions of the newbies emerge.

How can participation in a BarCamp improve “staff inventiveness”

Recent studies show that companies should particularly foster self-responsibility and autonomy of their staff in problem solving processes [8]. If employees would then be confronted with the task of finding new, “innovative” solutions out of their specific field of knowledge – thus in the spirit of TRIZ learning from other professions – they could first flesh out the task and problem situation, followed by a creativity session similar to a BarCamp, generating ideas with “external” participants. The discussion with participants outside their own subject area would greatly help push their thinking in new directions. TRIZ-Tools like feature transfer or function oriented search would be ideal tools for such sessions, because they open up the thinking process and speed up the transfer of “foreign” solution concepts into the own field.

Another obstacle regarding open innovation with external participants can also be eliminated by TRIZ-Tools: Classified information can be covered by translating the specific situation into TRIZ problem models of TRIZ. The abstract formulation of the task also makes it easier to look into other branches. This way, external partners can be included into the ideation process, enhancing mutual understanding and appreciation of different viewpoints and approaches. [8, 9]

Experiences in BarCamps can therefore improve cooperation as well as speeding up problem-solving and product-development processes that are currently needed for the development of an agile culture in teams. [6]

If employees are trained in working with partners of different professional background, the “not-invented-here” syndrome can also be significantly reduced. One important driver in overcoming this effect lies in the active promotion of exchange and creative cooperation of affected people. During the BarCamp this mechanism could be observed during the session “How will financial services develop in the future?”, where engineers and financial experts were able to work together. [7]

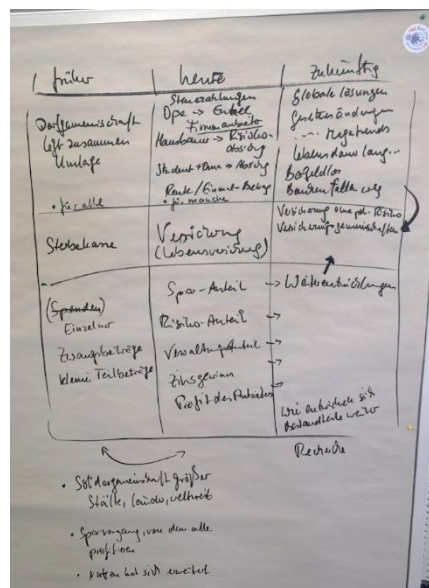


Fig. 6. BarCamp Session “Financial Services”, 9-Screen-Model

4 Conclusions

The following conclusions were summarized after the BarCamp, taking into account the feedback of the participants as well as the observations of the authors, who have extensive experience in facilitation innovation sessions in industrial settings.

For short TRIZ sessions it is crucial to have a thoroughly prepared problem analysis to point out the crucial key problems to be addressed during the session. The “Innovation Situation Questionnaire” could be used for preparation. Also the goal of the session and the desired solution space needs to be defined.

The use of graphical representations is extremely helpful for explaining context and correlations regarding the system structure (TRIZ Function Model) or the problem situation (Substance Field Model, Contradictions). These tools, when used with common language, are also understandable for the “TRIZ-newcomer”.

The language and syntax used in the TRIZ Function Model helps to quickly understand the system structure and interactions, enabling participants from all different kinds of knowledge background to collectively focus on the task at hand.

The TRIZ solution models (e.g. Standard Solutions, Inventive Principles, Separation Principles) need explanation or even re-wording by the moderator, ideally also prepared in advance. Examples for the problem models help understand the underlying meaning of the solution model and help overcoming the psychological inertia and look in different directions offered by TRIZ. Unmodified use of e.g. the standard solutions is likely to alienate the TRIZ newbie, making it harder to focus on idea generation because it takes time to figure out what the solution model is about.

The role of a moderator is mandatory, especially for short, focused TRIZ sessions. It is compulsory that the process of the TRIZ session is monitored as well as the discussions between the participants. Especially short TRIZ sessions need a “game plan” and a structure beforehand, balancing time for analysis, discussion, free association and guided idea generation with TRIZ tools. Discussions between the participants need to be monitored and limited if necessary to stay on track. If TRIZ newbies are participating, it is even more needed to have a “translator” for the TRIZ-specific syntax and wording.

Acknowledgements

The organizers of the first German TRIZ BarCamp would like to thank the International TRIZ Association MATRIZ for supporting and sponsoring the event. Our thanks also go out to the VDI for support as well as all participants of the BarCamp that helped to make this day a memorable and successful experience.

References

1. <https://de.wikipedia.org/wiki/Barcamp>
2. <http://lifevest.zoll.com/de/medical-professionals/>
3. https://en.wikipedia.org/wiki/Wearable_cardioverter_defibrillator
4. <https://www.hrsonline.org/content/download/18186/804164/file/Wearable-Cardioverter-Defibrillator.pdf>

5. Bertoncelli T., Mayer O., Lynass M., “Creativity, Learning Techniques and TRIZ”, ETRIA TRIZ Future Conference 2015, Berlin, October 26-29 2015
6. Hollmann, Jens; Daniels, Katharina „Anders wirtschaften. Integrale Impulse für eine plurale Ökonomie“ 2., aktualisierte Auflage, Springer Gabler, Wiesbaden 2012, 2017
7. Chris Barez-Brown „How to have Kick-Ass Ideas. Get Curious, Get Adventurous, Get Creative. Skyhorse, 2008
8. VDMA “Führung und Innovation in Zeiten der Digitalisierung”.Frankfurt, VDMA e.V. Business Advisory 2018
9. VDMA “Führungskultur und Industrie 4.0 durch die Brille der Kulturwissenschaften” IN: Wie arbeiten wir in der Zukunft?. Die betriebliche Praxis zwischen Vision und Gegenwart”,.Frankfurt, VDMA e.V. Business Advisory 2017

Communication

Communicating Author: naehler@c4pi.de

TRIZfest 2019

September 11-14, 2019. Heilbronn, Germany

THE CONTRIBUTION TO TRIZ BY THE INVENTOR SCHOOLS IN THE GDR

Hans-Gert Gräbe

Leipzig University, Leipzig, D-4109, Germany

Paper Classification:

- Best practices, business experiences, integration with non-TRIZ methods/tools
- Educational methods and experiences

Abstract

On the basis of an analytical scheme developed in [1] the analysis of the theoretical heritage of the inventor school movement in the GDR is continued in more detail. We provide an analysis of the tension between theoretical-methodological positions and productive-practical dynamics in the short time of the boom of the GDR inventor schools in the 1980s and describe the most important theoretical results from the inventor school systematics.

Keywords: inventor schools in the GDR, ProHEAL methodology, ABER matrix.

1 Inventor Schools as an Example of a Socio-Technical Development

In [1] – using an ARIZ-like approach to socio-technical analysis – an analytic scheme was proposed to describe and reflect the development of the inventor school movement in the GDR as a specific form of TRIZ practices in their contradictory dynamics. This analytical scheme, that can also be applied to other TRIZ practice contexts, considers TRIZ as part of the inventive system within the given society model. The idea to apply TRIZ's analytical and methodical concepts to the historical analysis of TRIZ itself is inspired by the essay [11], that outlines the general potential of applying TRIZ to the analysis of contradictory societal processes.

In the context of the well-known 9-fields approach the application of such a methodology to the history of the inventor school movement in the GDR must first adequately apply system modeling to identify and model the correct place of the inventive system on the one hand in relation to a more general social supersystem and on the other hand in relation to appropriate subsystems. In a first approximation the structures of the inventive system are in tense conflicts with the socio-political system as *supersystem* and with the economic-productive system as *subsystem*. In the course of this analysis, in [1] three components of the inventive system are identified that are significant for the analysis of the inventor school movement,

- the theory of Systematic Heuristics according to Müller (SH),

- the potential left over from the short theoretical and practical boom of cybernetics in the years 1965-1974 in the form of persons trained in dialectical, contradiction-oriented thinking (DC) and
- the personal and structural potential of the *Honoured Inventors* (“Verdiente Erfinder”, VE) – a system of ideal and material gratification of invention achievements, existing in the GDR since 1952.

These components show different dynamics over time, which is, compliant to TRIZ theory, taken in [1] as reason for remodeling. After a substance-field swap, the inventive system is no longer regarded as *unit of modeling* (“substance”), but as a *mediation* (“field”) between the relational structures between the socio-political and inventive systems (1) on the one hand and between the inventive and the economical-productive system on the other hand, thus considering those initially relational structures now as units of modeling (“substances”).

Such *substance-field swaps* as basic remodeling principle play a minor role in the current TRIZ practice, although such a transition from verbs (to designate relational aspects, “fields”) to nouns (“substances”) is essential and far-reaching in philosophy representing a common abstraction principle. An obstacle to apply this principle comes from an *immersive* system notion that is widespread in TRIZ practice and reduces the relationship between the supersystem and the system to a simple inclusion relation. Such an approach insufficiently takes into account that modeling is not concerned with the real-world systems themselves, but with *descriptions* of such systems, that necessarily require abstractions and reductions. Due to the relative autonomy of the forms of movement of the socio-political and inventive systems in our context, a hierarchization of system levels can only be used to a limited extent, but on the other hand does no more play a prominent role in a *submersive* system notion. Hence, we consider the three systems (socio-political, inventive and economical-productive) as independent to a certain degree² and do not reduce the relationships between them to a pure embedding. This concept is described in [1] in more detail.

Furthermore, in [1] we discussed, to what extent such an approach – the consideration of the inventor schools in particular and of TRIZ in general as a *mediation structure* between the poles of two social relation areas, on the one hand TRIZ as theory (1) and on the other hand TRIZ practices (2) – is necessarily reductionistic. Such a reductionism results from the consideration of the areas (1) and (2) as “substances”, thus suppressing the analysis of their *inner* contradictions in favour of focusing on the contradictions and forms of movement within the field of tension *between* TRIZ theory and TRIZ practice.

In this essay such a problem access is granted as given. In [1] we considered more closely the period from 1960 to 1990 that can clearly be divided into three phases (1960th, 1970th, 1980th) with different emphases at the level of the supersystem. Such gradual changes at that level are manifested in significant *structural* changes at the level of the inventive system. In this essay, the period of the inventor schools of the 1980th will be analyzed in more detail. We refer to [2] for detailed information about the inventor school movement in the GDR.

2 Such an independence is part of an abstraction process in system analysis that puts a frame of separation on the complex interdependencies of the “real world”. Such an by its very nature *reductionistic* abstraction process can be considered as the core of the substance-field approach in TRIZ, see [1] for details.

2 Inventor Schools – a Refinement of the Analysis

In the last section we described our approach to analyse TRIZ history in its movement forms of tense relation between TRIZ theory and TRIZ practices. In this approach TRIZ theory and TRIZ practices act as *poles* of an exchange relationship between the different area of conflicts in (1) and (2). This analytical approach was used in [1] already to explicate a rough pattern of *theoretical* contributions of the inventor schools to the further development of TRIZ, attributing the component VE to the pole of TRIZ practices, whereas the components SE, DC, and also the system of TRIZ approaches in a strict sense are attributed to the pole of TRIZ theory. This analysis will now be deepened.

The pole of TRIZ practices in that setting definitely needs to be supplemented by the practices of the *specific inventor schools and their participants*. In order to clarify the dynamics of this context, we cite a longer quote from [3] that describes the typical inventor school situation (translated from German by HGG):

“The EKO (‘Eisenhüttenkombinat Ost’) hosted the first inventor school in 1982/83, in which I participated. In this context, within the KDT company section, a working group ‘inventor activity / creativeness’, headed by Dr. Papert, was founded in April 1983. Members of this working group were preferably graduates of the inventor school. The tasks will be reported below.

Trainer of the first inventor school was Dr. Herrlich from Leipzig, himself a Honoured Inventor and a leading coach of inventor schools. The training rooms were outside the company. The goal was to familiarize the participants in a place far away from the living and working area with the invention methodology in a focused and undisturbed manner and to let them work. The motto of the inventor schools was: ‘Experienced inventors train future inventors’.

At the end of the first week, the participants had to process the identified information deficits of subject-specific and IPR-specific nature until the second week of training. In the final work after the second week, patentable solutions should be realized. Each graduate had to formulate an implementation concept for this purpose.

Participants should in any case handle an actual operational task from the company with the objective of a patentable solution. Thus it was clear that already existing collectives, preferably with their leader, should take part in the inventor schools. However, this also required that the engineers came up with demanding topics. With the implementation of inventor schools, there were demands on the topics that had to be dealt with, that often made the difference between claim and reality in the area of company research clear. ...

Basically, it should be noted that the college and technical college engineers were very open-minded about the invention methodology and after completing the inventor schools were very motivated to work on the tasks. Unfortunately, the topics often did not have a level that would have made scientific and technical excellence possible. Here compromises had to be made in relation to the actual concerns of the inventor schools. ...

The inventor schools were supplemented by the mediation of mathematical-statistical experimental design and evaluation and separate courses and commercial offers for computer-aided inventions. Own materials came from the district center of innovators (‘Bezirksneuererzentrum’) in Suhl, that among other things also carried out courses on computer-aided inventions. This technical support had not obtained practical importance in the company.”

For further analysis it turns out that the personnel tableau has to be divided into two categories – the *coaches* and the *participants*. For the participants the solution of specific economic-technical tasks was in the foreground, for the coaches the *problem-related mediation of suitable methodologies*. [2:13] lists a considerable number of such coaches.

The elaboration and fixation of such methodologies in handouts and the consolidation of a corresponding *mediation system for methods* represents an independent challenge that was addressed only selectively in the short time of existence of inventor schools and was essentially limited to the preparation of handouts and their (under real socialist conditions difficult) publication and distribution.

The first approaches towards an *independent methodological work-up* can be found in the dissertations [4] by Linde at TU Dresden and [5] by Herrlich at TH Ilmenau. Further effort to work up the methodological heritage of inventor schools, such as [2], [6] or [7-9], took place only after 1990, at a time when the springs of inventor schools TRIZ practices already dried up and the systematization was only possible in retrospective form.

To play back these experiences in the *further development of the TRIZ corpus* itself not only such a systematization is required, but also appropriate personnel and structural framework conditions, i.e. a sufficiently efficient academic context. The corresponding systematizations in [2], [4] or [6] represent at best a beginning of such an assembly, a systematic merge of the theoretical heritage of the inventor schools with the theoretical development of TRIZ in the last 30 years is still pending.

In this short analysis, within the inventive system we have identified four roles and three communicative interconnections, that further structure the inventive system as a major mediating link between (1) and (2). These are the roles of *participant*, *coach*, *leading coach* and *master* as well as the mediation relationships on the levels

- (a) of practical methodology (coaches – participants),
- (b) of further development of the methodological mediation structures (a qualification system of coaches by leading coaches as well as the embedding of such a training in the academic educational structures) and
- (c) of further development of the academic foundations of these innovation methodologies.

While the systematic heuristics (SH) reached a wider spread in the 1960s starting from the academic system (c), the inventor schools as well as Altshuller's approaches at Soviet times remained in its core outside academia, as Thiel [10] explains for the academic recognition of [4] in greater detail.

3 Theoretical Approaches within the Inventor School Systematics

With ProHEAL (“Programm zum Herausarbeiten von Erfindungsaufgaben und Lösungssätzen”) [10] and WOIS (“Widerspruchs-orientierte Innovations-Strategien”) [6, 10] two theoretical versions of the inventor school methodologies have been elaborated in more detail.

Common to both approaches is that compared to Altschuller's original, where the potential of *administrative contradictions* is not considered systematically, the *technical-economic* problem field is considered as a separate level, in which “the relation between products, goods and purposes” [2:57] have to be explored in more detail. Such a perspective nowadays is experiencing a renaissance, especially in the area of agile approaches, since it is increasingly counterproductive to leave the requirements analysis to the management and to limit the responsibility of the

engineering and technical personnel to the realization of previously specified requirements. This potential is already highlighted in Part 3 of [2] entitled “Perspectives of Inventor Schools in the Market Economy”.

Similar to ARIZ, these three *levels of contradiction* are operationalized in a *path model*. The “problem areas in the path model of inventive methodology” [2:106] are identified on the one hand as mediation between different levels of detail of the problem analysis and on the other hand stem from the contradictory nature of different levels of conflict.

On the *technical-economic level*, the technical-economic problem situation is developed in a person- and process-related analysis as the conflict of objectives between potential needs in the sense of a requirement analysis and the (technological) state of the art. As result of this level of analysis listed in [2:59] one obtains

- the *technical-economic goal* of the innovation project,
- the *basic variant* of a process and/or product innovation that meets demand in a technological sense,
- the *critical functional area* in the multi-dimensional optimization space of this basic variant,
- the *technical-economic contradiction* (TEC), that stands in the way of an optimal design and dimensioning of the basic variant.

[2] continues: "If it is not possible to derive a basic variant from the state of the art that can be optimized in terms of the technical and economic objectives, then there arises an *inventive problem*. The solution of the TEC is then the goal of the invention”, on which the further analysis has to be focussed.

If a basic variant is found, then the *techno-technological level* is entered, in which all facts are to be analysed, “that concern the technical system of the basic variant, its structure, function, its behaviour and its immediate technological environment.” [2:60] As result of this level of analysis one obtains

- the *ideal technical subsystem* in the critical functional area of the basic variant that solves the TEC,
- the *unwanted effects* as undesired technically disadvantageous effects of the ideal subsystem on the functional behaviour of the basic variant,
- the *critical range* in the functional structure, to which the causal correlation of the ideal subsystem and the undesired effects extend,
- the *technical-technological contradiction* (TTC), that stands in the way of the attempt to eliminate or suppress the undesired effects by varying the functional principle of the ideal subsystem.

[2] continues: “If the technical subsystem with the alternative functional principle for the critical functional area of the basic variant can be found without a significant undesirable accompanying effect, then an *invention* is present as a solution of the TEC. Due to the heuristic approach, this often turns out to be a *clever simple solution* (‘raffiniert einfache Lösung’ – REL) in the low-tech sector, that in the best case requires only application-specific testing. ... If the solution is not achieved in this problem field level, then from the previous analysis the problem

may be formulated as a *precise invention task*, that includes the TTC as well as a solution strategy tailored to this contradiction. This amounts to defining the harmful natural law in the critical area of the functional structure and replacing it with an alternative known active principle”, that is to be analysed in more detail on the third problem field level.

On this *technical-natural-law problem field level* “all circumstances come into consideration, that concern the operating principle, the conditions for its technical use as well as its theoretical and experimental foundations. The considerations are model- and event-driven and determined by relations between fields, factors and effects.” [2:60] As result of this level of analysis one obtains

- the *ideal operating principle* in the critical effective range of the functional structure in the sense of the solution of the TTC,
- the *harmful natural law* that opposes to unfold the ideal operating principle,
- new *technical-constructive boundary conditions* in the critical range of action that suppress the effect of the harmful natural law,
- the *technical-natural-law contradiction* (TNC), that prevents a deployment of the ideal operating principle by varying the technical-constructive boundary conditions in the critical range.

[2] continues: “If the new mode of action can be technically unfolded to the extent necessary for functional performance in the critical area, then an *invention* as the solution of the TTC is present. Since this enters new technical and scientific territory, the solution is usually located in the high-tech field. It requires application-oriented basic research for its verification. ... If a problem solution is not found in this way, then one has to deal with a system-inherent TNC, that questions the development and viability of the system as a whole. As solution strategy one has to search on a suitable, hitherto unknown principle of action or on a fundamental process innovation. Both solution strategies usually go beyond the framework of a time and financially definable innovation project.”

This methodical framework was condensed to a “Program Sequence to Work out Invention Tasks and Solutions” [2:107-109], in which ARIZ-like process sequences in each of the three operation fields are coupled together via narrow interfaces.

Contradictions of various kinds are to be identified on all three levels, for which a uniform methodological instrument was developed with the *ABER Matrix* as a “strategic tool for contradiction-aware inventions”. [2:62]

On the technical-economic level, this matrix is defined as a *target matrix* with 16 fields to “systematically determine the targeting requirements, conditions, expectations, restrictions³ (as rows of the matrix) in terms of functionality, economy, controllability, usefulness (as columns of the matrix)”. It serves “to question systematically the actual need for action, the action objectives and the project idea underlying the innovation project. ... The ABER matrix is intended to anticipate all conceivable ‘yes, but’ prejudices to an invention when it comes to putting it

3 In German: **A**nforderungen, **B**edingungen, **E**rwartungen, **R**estriktionen – the source for the acronym ABER, that translates also as “but”.

into production or on the marketplace.” The technical-economic problem is basically formulated as determining the main variable that, with its variation, causes other significant target parameters to deteriorate to an impermissible extent or to go beyond given limit values.

On the technical-technological level, the ABER matrix is used as a *critical function matrix* with 20 fields to “define the technical-technological innovation goal in the form of the ideal subsystem” by systematically recording the “functional requirements, the design and manufacturing conditions, the technological influences, the natural law restrictions⁴ (as rows of the matrix) in terms of operand, operation, operator, counteroperation, counteroperator (as columns of the matrix)” to record the “technical-scientific solution needs” by a functionality-related structure analysis, to define the critical functional area and the interface conditions for the ideal subsystem both structurally and functionally.

On the technical-natural-law level, the ABER matrix is used as an *activity field matrix* with 12 fields for scientific-mathematical modeling to produce a “working hypothesis on the processes in the critical effective range of the ideal subsystem”. It is used to record systematically the “requirements, conditions, insights, restrictions⁵ (as rows of the matrix) with regard to technically exploitable effects, technologically to be controlled side effects and accompanying effects, constructively controlled counteractions and lead effects in the functional structure of the ideal subsystem (as columns of the matrix)”. The description of the causal relations between the defined activity field parameters is more complicated. “The problem is still the TTC. The solution goal is now the new active functional principle according to the solution strategy. The solution goal is thus no longer directly oriented to the invention, but primarily based on natural scientific gain, that opens up new spaces of solutions for inventive thinking.” [2:64]

4 Conclusions

In this paper, the theoretical heritage of the inventor school movement of the GDR was analysed in more detail. On the basis of an analytical scheme, that was itself developed in [1] with an ARIZ-like methodology, we provide an analysis of the tension between theoretical-methodological positions and productive-practical dynamics in the short time of the boom of the GDR inventor schools in the 1980s. Already at that time it became clear that the broad practical availability of innovation-methodical skills in the engineering and technical area is strongly required for a developed industrial society to survive in the worldwide economic competition. The three areas of mediation

- (a) practical methodology as an offer for continued professional education by trained coaches,
- (b) further development of the methodical mediation structures by coach qualification as well as anchoring it in the academic education of future engineers and
- (c) further development of the academic foundations of these innovation methodologies

4 In German another ABER: **A**nforderungen, **B**edingungen, **E**inflüsse, **R**estriktionen.

5 In German a third ABER: **A**nforderungen, **B**edingungen, **E**insichten, **R**estriktionen.

further structure the inventive social system as a field of tension between the socio-political and the technical-economic social systems, formerly also – and possibly more precisely – identified as a field of tension between *relations of production* and *productive forces*.

In Section 3 essential theoretical positions are referenced, which are rooted in the experiences of the inventor schools of the GDR. [2] as probably the most instructive methodical systematization of these experiences so far is used as a reference. The focus is on the effort to raise this wealth of experience for the debates on the further development of TRIZ theory. A precise classification of these results in the TRIZ theory building with all its winding corridors and rooms requires a more comprehensive processing of this heritage, which is still to be afforded.

References

1. Gräbe, H.-G. “Наследие Движения Школ Изобретателей в ГДР и Развитие ТРИЗ”. To be presented at TRIZ Summit 2019 in Minsk. For Russian and German versions see <https://hg-graebe.de/EigeneTexte/>
2. Rindfleisch, H.-J., Thiel, R. Erfinderschulen in der DDR. Eine Initiative zur Erschließung und Nutzung von technisch-ökonomischen Kreativitätspotentialen in der Industrieforschung. Rückblick und Ausblick. Berlin, 1994.
3. Thomas, B. Die KDT Erfinderschulen der DDR. Talk at the 21. Leibniz Conference «Systematisches Erfinden», Lichtenwalde, 2016. http://leibniz-institut.de/Konferenzen/TRIZ-2016/Vortrag_Bernd_Thomas.pdf
4. Linde, H. Gesetzmäßigkeiten, methodische Mittel und Strategien zur Bestimmung von Erfindungsaufgaben mit erfinderischer Zielstellung. Dissertation, TU Dresden, 1988.
5. Herrlich, M. Erfinden als Informationsverarbeitungs- und -generierungsprozess, dargestellt am eigenen erfinderischen Schaffen und am Vorgehen in KDT-Erfinderschulen. Dissertation, TH Ilmenau, 1988.
6. Linde, H., Hill, B. Erfolgreich erfinden: Widerspruchorientierte Innovationsstrategie für Entwickler und Konstrukteure. Darmstadt, 1993.
7. Zobel, D., Hartmann, R. Erfindungsmuster. Expert Verlag, Renningen 2009.
8. Zobel, D. Systematisches Erfinden. Expert Verlag, Renningen, 2009.
9. Zobel, D. TRIZ für alle. Expert Verlag, Renningen, 2012.
10. Thiel, R. Erfinderschulen – Problemlöse-Workshops. Projekt und Praxis. LIFIS-Online, 2016. http://dx.doi.org/10.14625/thiel_20160703
11. Schollmeyer J., Tamuzs V. Discovery on purpose? Toward the unification of Paradigm Theory and the Theory of Inventive Problem Solving (TRIZ). In Cavallucci D., De Guio R., Koziółek S. (eds.). Automated Invention for Smart Industries. Proceedings of the TFC 2018. Heidelberg, 2018.

Communication

Communicating Author: graebe@informatik.uni-leipzig.de

TRIZfest 2019

September 11-14, 2019. Heilbronn, Germany

THE METHODS OF STEP BACK FROM IDEAL SYSTEM

Ahreum Lee^a, Jungin Kim^a, Wansoek Jeong^a, Gukhyun Cho^a, and Youshin Han^b

^a*LG Electronics, Seoul, 07336, Republic of Korea*

^b*CTL (Creative Tree Lab), Seoul, 06224, Republic of Korea*

Paper Classification:

- Theoretical, research results
- Case study

Abstract

In TRIZ, ideality is a very important concept. Through TRIZ ideality and ideal final results, you can identify the problem that you ultimately want to solve. The concept of the ideal system allows one to concentrate on the function to be performed. We can ask the question ‘what is needed?’, rather than concentrating on improving the existing system. In part 4.2 of ARIZ 85C, it is recommended to step back from ideal final result. As results of step back, we can draw a micro problem, which provides a hint for problem solving. However, though many books and papers mention the necessity of step back process, there is a lack of specific method or examples of the said process. In this paper, the specific method of step back from ideal system is presented. Furthermore, through the case study using step back, we can identify how different directions of problem solving are presented and its effectiveness in solving the problem.

Keywords: *Problem definition, Ideality, Ideal system, Step back*

1 Introduction

1.1 Importance of problem definition

With the advent of the era of the fourth industrial revolution, the latest hot issue in manufacturing is the establishment of smart factory. Ideal factories that do not have unreasonable elements within the process, are called ‘Smart factory’, as they think for themselves and communicate between people and equipment. People think the concepts of process automation and smart factory are often the same, but in fact, they are different. Although process automation cannot deviate from programming logic, smart factories themselves perform decision-making or control and management of fluctuations, that have traditionally been the human territory. However, a fundamental problem definition of what to control and what to manage is yet human's own.

Dave Snowden of IMB has classified four categories of problems that businesses are experiencing: 'simple problems, difficult problems, complex problems, and confusing ones.' (1) Simple and difficult problems can be solved through learning. But complex problems require considerable logical thinking, and confusing problems mean that even causality is unclear. The problems of the Fourth Industrial Age are the complex and confusing ones. Therefore, the ability to define what the problem is will become more important in the future.

TRIZ defines the difference between the current level (as is) and the goal (to be) as the problem. This means that the problem defined varies depending on the target point. In this paper, we studied the ideal final result, the concept of defining goals in TRIZ, and analysed how the problem changes with the implementation of step back from the ideal final result. The case study also confirms the effectiveness of 'step back' from the ideal.

1.2 Ideal system and concept of step back

Definition of ideality and ideal System

Ideality eliminates the concern of 'How can I improve a little bit more?', and ultimately sets a target image to get the 'what'. And Ideality serves as the navigation to prevent from losing your way in the problem-solving process.

Ideality may be defined by the following formula (1) :

$$\text{Ideality} = \frac{\sum \text{Useful Functions}}{\sum \text{Harmful Functions} \times \sum \text{Cost}} \quad (1)$$

This means that the sum of useful functions that a technical system has should be increased, or that harmful functions and cost that the technical system has should be reduced. So, what does it mean to be the infinite ideality? It means that the numerator must be infinite or the denominator must be zero. By defining infinite ideality as a state in which no inputs (costs) are needed in the system, and only useful things are obtained without harmful effects, we can think about the ultimate perspective and break down the psychological inertia.(2)

G.S. Altshuller, TRIZ Founder, describing ideality as an ideal solution or an ideal final result (IFR), said, "The IFR can be likened to a rope that holds us when we climb steep mountain. '(3) That is, we should always seek ideality throughout the troubleshooting process.

Step back form ideality

The concept of Step back was introduced at the ARIZ 85 which is an algorithm for the TRIZ problem-solving process. Part 4 of ARIZ 85C is for utilization of Substance-Field Resources. Step 4.2 guides you "Step back from IFR(Ideal Final Results)." Here the meaning of Step back is to apply very minimal compromiseable changes to the final results of the desired system, Altshuller states.(3) For example, if having two elements in contact is the desired result, introduce a very small gap between these two elements. As a result of the step back, the problem changes from 'how to get the two elements in contact?' to 'how to remove this small gap?'

Example of step back

Thinking of ideality and ideal results clarifies the target point and helps break the stereotype when solving problems in actual work site. However, after defining an ideal system in the actual site, it often is too ideal from the actual problem that developers are unable to know where to

start the approach from. For example, the keyword 'unmanned manufacturing' is such the case. When the goal is the unmanned assembly lines for a specific product, the project members will not know where to begin and how to achieve the ideal of the unmanned system.

There will be many problems to be solved, including supply and alignment of parts, assembly, and structure of products for unmanned manufacturing. The Table shows the ideal final results and its step back process accordingly, based on the problems redefined only from the structural perspective. What is the most ideal product structure for unmanned assembly line? It would be a system that does not even need to be assembled, and there would be no assembly structure in itself. To achieve this goal, the direction of the problem is set to no-assembly, but we focus on how to achieve this function. The solution would be achievable if the original product structure were a one-body structure that did not need to be assembled. Of course, other ideas could also be presented. If the presented idea is also likely to be difficult to achieve, we will have to go through the step-back process; to have minimum number of assemblies, but with self-assembled structure. Here, the problem would be how to minimize the number of assemblies

Table 2. Step back from ideal system

Step back	To be (Goal)	Solution Directions
0	There is no need to assemble.	How do we make the product a single or unibody structure?
1	It is self-assembled with a minimum number of assemblies.	Can we have the product modularized or semi-automated?
2	Though numerous assemblies are required, the assembly is easy.	What is an easy-to-automate assembly structure?

The structure may need to be modularized, or parts may need to be semi-automated by simply using magnets and placing them close. If this also is not viable, then we can step back again. There may be multiple assemblies but could be facilitated for easy automation. It is possible to simplify the direction of entry of the screw, or replace with a hook structure instead of the screw, which can be tightened by a push, or a guide structure which leads the assembly system to find its own position. We can see that each step back from the ideal goal we take, the direction of problem solving changes.

Methods for step back

Practically, getting the participants to define an ideal system or an ideal outcome in the actual field, they can define based on the definition of an ideal system or IFR, without much trouble. However, they do often express difficulties in the step-back phase in actualizing the objective.

In such case, we could observe that it was helpful to conduct a root cause analysis to identify the root cause of each problem and to analyse what was interfering from achieving the goal. As the root cause analysis is performed, the problem is broken down into lower components level and the problem is actualized with the parameters associated with the components. Using the

mentioned components and parameters results of root cause analysis, the directions to improve the step back become more diverse.

2 Case Study

Problem situation

This is a case of LG Electronics' 2015 development of premium OLED TV, where developers had a difficult time designing the structure to implement scenarios. The user scenario of this TV is which the Display and AV Box modules are separated, and the AV Box is equipped with various control parts, audio and wireless modules, where this AV Box is used a stand for the Display. The concept is expressed in Fig.1. For the wall-mounted scene, the AV Box would be folded behind the screen, allowing the TV to be wall-mount convertible with a minimum space from the wall.



Fig. 1 OLED TV concept: Stand – Wall mount convertible structure

The problem was the joint structure connecting the Display to the AV Box. In order to convert between stand and wall-mount scenes, the parts on display and parts on AV Box had to be assembled using four long screws. This work required good assembly structure because overseas customers often assembled the product themselves. However, the assembly was even difficult for the trained developers due to unaligned screws or too much force being required for assembly. The AV Box and the display connection structure at the time are shown in Fig.2

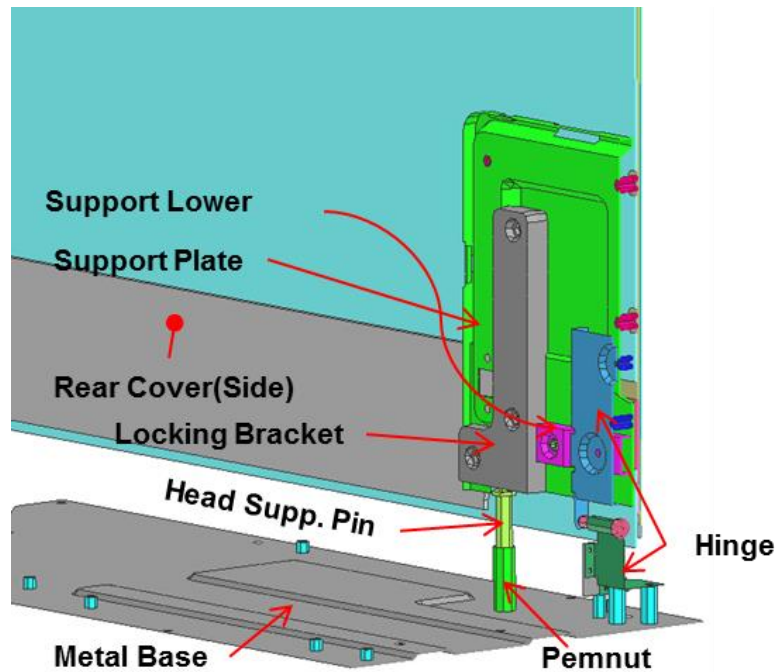


Fig 2. Display and AV Box connection structure

Fig. 2 shows some of the mechanical structures on the back of the TV. Behind the OLED display, there is a support plate that supports the screen, and a metal diecasting called Locking Bracket is attached on the support plate. The lower part of the locking bracket had a tap where the screw could be tightened. The metal base at the bottom of the AV Box to reinforce structure had embedded pemnuts. The long head support pins were assembled into the tap structure of the locking bracket through the pemnut.

The same tightening structure existed in four locations based on a 65-inch screen. In fact, during the tightening process, the same problem of unalignment between head support pins and taps occurred frequently, which caused the threads on head support pin to be damaged. Developers were looking for materials to improve the strength and rigidity of the head support pin at the time.

TRIZ Root Cause Analysis

Root cause analysis was performed, as in Figure.3, to determine what actually makes it difficult to assemble.

When you perform a root cause analysis, the problem is redefined as a parameter for various parts. The main thesis of this paper is to derive various parameters through RCA, and then make a stepback in terms of each parameter.

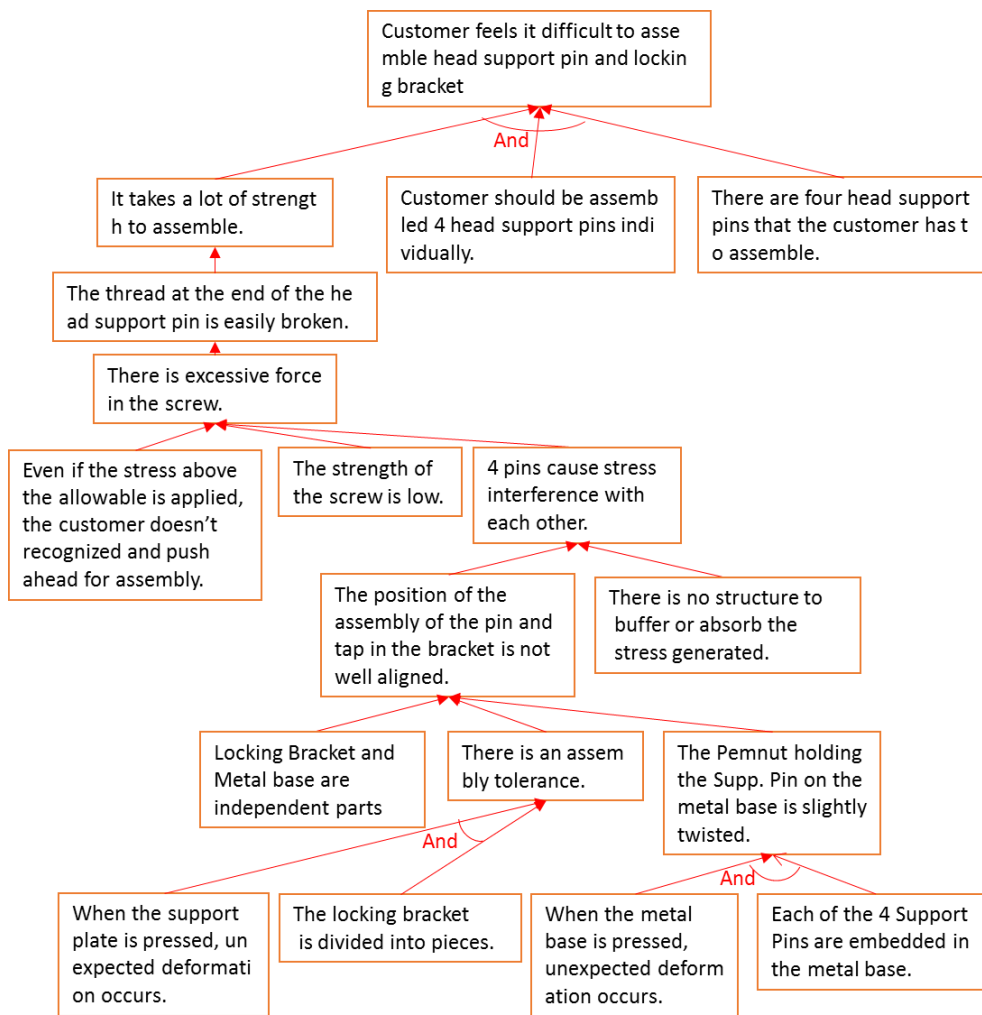


Fig.3 Root Cause Analysis

Based on the root cause analysis, it was found that there were four tightening spots, that each tightening was carried out individually, and that the structure was prone to stress interference. In other words, by performing root cause analysis, parameters such as ‘number of tightenings’, ‘difficulty of tightenings’, ‘tightening stress’, etc., could be derived. Based on these parameters, we assumed the most ideal situation and performed Step back from the ideal results.

Ideal goal setting and steps back

The most ideal goal is nonassembly. Whichever scene, whether it is folded or spread, the customer shall do so without the assembly process. The strong reason for defining an ideal final result is because even with just imagining such result, we were able to come up with a much better structure than the current architecture. Perhaps there are many structures that fold and unfold and support rigidly. But at the time, developers were immersed in the conventional structure and were chased by the development schedule, which had limited from thinking of other structure possibilities.

The ideal result is 'customer does not assemble'. The direction of the solution may be of a 'structure that is already assembled and can be folded and unfolded'. In this regard, the idea as shown in Figure 4 was derived. It has a structure that automatically catches the fixed structure when

folded and removed. If the automatic entrapment is difficult, a short screw may be used, at least for fixing.

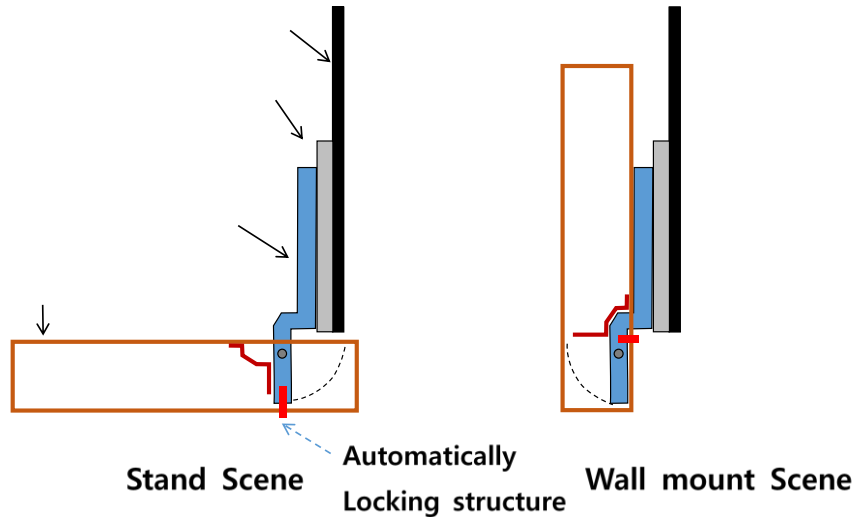


Fig. 4 Idea for making zero assembly

We can step back once more, and think of ‘one or two tightenings’, not zero. We couldn't draw any particular idea with regard to ‘one or two tightenings’. However, in the same situation with four tightenings, it was possible to perform a step back with the parameter ‘difficulty of tightening’.

We can think of the difficulty of tightening or no difficulty at all. Difficulties eventually are related to stress. The sources of stress first were due to long length of the head support pin, thus the final assembly would go wrong with the slightest distortion on start position (pennut), and the second was that the location of the pennut and the tap in locking bracket were not always constant. To further develop the root cause, the metal base is press-processed, so perfect shape control is extremely difficult due to spring back effect, and the pennut fixed on metal base is unavoidably distorted. Therefore, regarding the new goal for 'four tightenings but easy assembly', we could think of shortening the screws and removing stress.

Step back may be possible again for the direction of stress removal. The ideal result is no stress in the first place. Four pins are needed for the stand scene, and may not be necessary for the wall-mounted scene (separations by time). To avoid stress, four pins need to move like one body, not individually. The LM Guide structure was mentioned as the approach that connected the four pins to move like a single body without distortion. However, the system became more complex and costly, and was excluded from the final choice. If it's unlikely to create a structure that doesn't make stress at all, you can step back again. Even if stress occurs, it may be removed quickly or could be a structure that absorbs stress. In this direction, an idea was derived that gave some Gap to the assembly position while maintaining the existing structure. This Idea is shown in Figure 5.

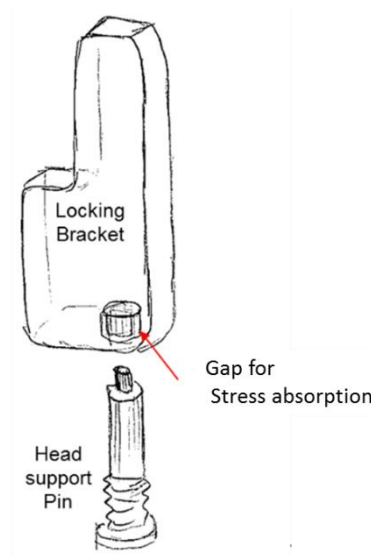


Fig.4 Structure of stress absorption

This was a very simple idea, just giving the existing tap location a little more assembly space. It has not changed the existing structure at all. At first, we were worried that the display would not be fixed properly, but in conclusion, it was a very effective idea. The assembly-ability improved without causing any degradation for fixing function or quality.

The solution directions according to step back are arranged in table 2.

Table 2. Solutions directions by step back

To be (Goal)	Solution Directions
Number of Thightenings : Zero	It is released in a pre-tightened structure to prevent customers from assembling.
Number of Thightenings : One	If there is one head support pin, there will not be stress from interferece with each other.

Number of Thightenings : Four	Find a way for the 4 pins to be tightened at the same time.
Difficulty of Thightenings : Zero	
Number of Thightenings : Four	Maintain the number of tightenings but improve the structure to which stress can be absorbed.
Difficulty of Thightenings : Easy	
Preserve existing method	Provide the customer with an assembly guide. (ex. Don't use more than 00 torque when you assemble the head support pins.)

Applying ideas

Based on the parameters obtained from the root cause analysis, step back was performed in various ways, and ideas that correspond to each direction were derived. As a result of coming up with various ideas, the application of a gap for stress absorption, which results least changes in the existing system, was immediately applied and tested. In contrast to the concern that the screen might not be rigid, the tightening force is drastically reduced by increased tolerances of the assembly, and at the same time, the display is fixed well. The model was time-sensitive, so the idea of giving the gap was applied into the product structure immediately. However, the next 77-inch model had applied the most ideal direction: 'It doesn't need to be assembled'. A drastic change in the assembly structure based on such structure as Fig.4 has been made so that customers do not need to use long-length support pins.

3 Conclusions

With definition of ideality or ideal final result, we were able to confirm that a more ultimate goal could be set. It was also possible to diversify the goal level through step back from the ideal results and to ensure that the directions of solution were developed in a variety of ways. In addition, in the short term, the idea that had done step back several times was applied, but in the long term, the idea which had higher ideality was applied.

References

1. Tayler Pearson, 2017, The end of jobs(Korean), Bookie
2. Karen Gadd, 2011, TRIZ for Engineers, GS intervision
3. G.S. Altshuller, 2012, Creativity as an exact science : the theory of the solution of inventive, GS Intervision
4. <http://www.evocus.com/Textbooks/ariz85c.pdf>
Algorithm of Inventive Problem solving, Part 4.2
5. Terssia Hobeika, Tomasz Liskiewics, Darell Mann, “Case Studies in TRIZ : Fretting Failure in Automotive Electrical Components”
https://www.researchgate.net/profile/Tomasz_Liskiewicz/publication/268390058_Case_Studies_in_TRIZ_Fretting_Failure_in_Automotive_Electrical_Components/links/546a69030cf20dedafd3882f/Case-Studies-in-TRIZ-Fretting-Failure-in-Automotive-Electrical-Components.pdf
6. Youshin Han, “The process of designing an ideal goal”
https://matriz.org/wp-content/uploads/2018/08/You-Shin-Han_TRIZ-Master-dissertation_fin.pdf
7. G.S. Altshuller, “The Innovation Algorithm, TRIZ”, GS intervision
8. Petrov, V.M. Idealization of Technological Systems. - District Scientific-and-Practical Conference "Problems of Development of Scientific and Engineering Creativity of Engineers.
<http://www.trizland.ru/trizba/pdf-books/zrts-08-ideal.pdf>
9. D.Daniel Sheu, Chun Ting Hou, “TRIZ based Systematic Devide Trimming : Theroy and Ap-
plicaion”, Procedia Engineering 131 (2015) 237-258

Communication

Communicating Author: armissi7@gmail.com, ahreum.lee@lge.com

TRIZfest 2019

September 11-14, 2019. Heilbronn, Germany

THE WORLD IS DYNAMIC, THE EDUCATION IS LINEAR

Dr. Mark G. Barkan

Knoxville, 37922, USA

Paper Classification:

- Educational methods and experiences

Abstract

Until the end of the 19th Century, an educational institution was the only source of information and attending them was the only way to acquire information. The present educational system was developed based on this reality. The main goal of this educational system was to stuff students with facts. Today, we live in an information society with hundreds of sources of information. Last year's facts, or yesterday's, may not have any value today. Skills learned today will soon become obsolete and new skills must be mastered. For this reason, knowing how to learn, search for and acquire information is more valuable than being a learner-of-facts.

Keywords: *education, TRIZ-Pedagogy, creative and critical thinking skills, linear and non-linear thought processes*

*“Education is not the learning of facts,
But training the mind to think”*

Albert Einstein

1 Introduction

The classical Western educational system has its origins in the Middle Ages. That form of education not only served the needs of those living in the Middle Ages but has been used throughout the centuries very effectively in training the mind. It was based on an understanding of the power of the human brain to successfully deal with the realities of life. Its main emphasis has been on literacy and the uses of the mind through logic, rhetoric, memorization, scholarship, Bible study, and learning the languages of the Scripture: Latin, Greek, and Hebrew. When Harvard College was founded by Calvinist Puritans in the Massachusetts Bay Colony in 1636, its purpose was to provide the new colony with a learned clergy. Thus, Latin, Greek, and Hebrew were part of the curriculum. Teaching/learning of facts was the main goal of education. In the absence of the mass media, lecture was the main vehicle for knowledge transfer and the classroom was the place where this transfer took place.

Skipping to mid-18th Century and the First Industrial Revolution.

The field of human activities became much broader. The need for skilful problem solvers grew exponentially. As well as the need for manufacturing labor with the ability to read, write and count beyond ten. Thus, the need for some kind of educational system.

At the time, modern factory was considered the best structure/process for every new undertaking. Therefore, schools were fashioned after manufacturing facilities. This promoted a linear, step-by-step educational process. The structure was very logical, in the opinion of the people, who developed mass educational system. The subjects were assigned to every 45-minute class period and the breaks were placed after every class period. As a result, the new educational system was born.

2 Linear vs. Non-linear thinking

Why communication is so hard? How two, intelligent, educated people can come to such different conclusions on any given topic? Could it be because we don't all use the same processes to think? A great debate on this subject did not start yesterday and will not end tomorrow!

2.1 Logic and Creativity

Some of us pride ourselves on being logical. We think through ideas with the efficiency of a well-oiled machine. We enjoy structured thought and evidence-based conclusions. I'm sure you know the type – we plan out every step of a process, follow the Gantt chart to the "t", and ensure results within schedules and deadlines.

Others of us pride ourselves on being creative. We rejoice in the big ideas, in the new discoveries, and in the satisfaction of creation. We are always coming up with new ways to solve problems, love the questions "what if?" and don't mind jumping ahead in a conversation to tell you what we just thought of.

Or, perhaps, you represent some mixture of the two. Also, a very plausible scenario.

In this author's opinion, these two humans' characteristics, logic and creativity, are often correlated with two different, but not disconnected types of thought processes: Linear thinking and non-Linear thinking. Rather than argue that one is more important or practical than the other, I suggest that both linear and non-linear thought processes are integral to success in business and, on the grander scale, life.

2.2 The Linear Nature of Logic

"Linear Thinking" is defined as follows: Linear thinking is a process of thought following known cycles or step-by-step progression where a response to a step must be elicited before another step is taken.

Linear means "like a line", and so a linear process moves forward in a line. If $a = b$, and $b = c$, then $a = c$. The application of linear thinking can be found in the well-known Socratic Method: a form of inquiry and debate between individuals with opposing viewpoints based on asking and answering questions to stimulate rational thinking and to illuminate ideas.

Much of our world is indeed structured upon the concept of logic (very basic logic at least). We learn math, deductive reasoning, and tend to apply these logical processes to our everyday life. Our drive to do so comes from our inherent need, as cognitive humans, to categorize our experiences in our minds and make projections about what the outcome of an action will be. We compare our expectations with our experience, weigh the similarity, and adjust our thought processes as needed.

Linear thinkers are very much the same; they start at step one and usually do a good and efficient job of completing the task before moving on to step two. They are driven, focused, and don't easily get off topic. Does this sound like you? Perhaps. Or maybe it sounds like the person in the office you have a tough time working with?

2.3 The Dangers of Logic

There's a danger in relying too heavily on logic. The danger is in the determination of the starting point. Once a starting point is chosen, there are a limited number of logical conclusions to any given problem. For example, imagine a store owner who believes that he must raise his revenues to increase his profits. He tries multiple methods including advertising, increasing inventory, and cross merchandizing to bring in more customers and increase sales. But he forgot that he could also reduce his costs to increase profits, and in doing so missed what might have been much less expensive, less demanding options.

This example is simplistic, but it underscores the point that for any logical process, there must be a decided-upon truth as a starting point. And the beauty of logic, is that it allows us to reach an answer from a given starting point. It's easy, however, to rely upon starting points simply because they're what we've used all our lives – starting points that either may be false, or that limit us from finding a much better answer. In fact, many problems in our political and economic systems stemming from mismatched starting points.

2.4 2.4 Non-Linear Thinking

Non-linear thinking, a relatively new term, is vague enough (perhaps naturally so) that a simple google search will yield more beatings-around-the-bushes than formal definitions for the term. In my opinion, it is as follows: **Non-Linear Thinking** is human thought characterized by expansion in multiple directions, rather than in one direction, and based on the concept that there are multiple starting which one can apply logic to a problem. The theory of Open Problems definition and solution processes points from is based on the same premise.

Non-linear thinking is less constrictive – letting the creative side of you run rampant because of its inherent lack of structure. It's kind of like letting a puppy run wild on a walk up a mountain – anything of interest will be thoroughly investigated before jumping to the next, possibly non-related subject! It's very much like brainstorming – allowing thought to flow, unhindered, in attempts to arrive upon something special in the process.

Non-linear thought increases possible outcomes by not being so certain about the starting point for any logic process. Non-linear thinkers tend to jump forward, and from side to side through the steps of a project, in an effort to see the big picture and tackle those areas where they have the most interest. Where non-linear thinking falters is in finally carrying out the required action, because as a thought process it often encourages a user to agonize incessantly over where to start (that agreed upon truth, from which logic can be applied and action can be taken).

A form of Power Point presentation, created by the folks at Prezi.com, is a great example of non-linear and linear thinking in action. Why? Because rather than a linear slide show, it's ultimately a picture, into which you can zoom in and out, infinitely. It allows you to present a product, concept, or argument in a logically by moving from location to location what is essentially a group of images, but at any point you can zoom out and suddenly, "See the big picture", takes on a whole new meaning – just check it out yourself.

Is non-linear thinking the same as fragmented thinking? Who knows? Medically speaking, fragmented and disorderly thinking seem types of thought processes that are similar to "non-linear thinking" but more extreme in their severity. Fragmented thinkers, or disorderly thinkers

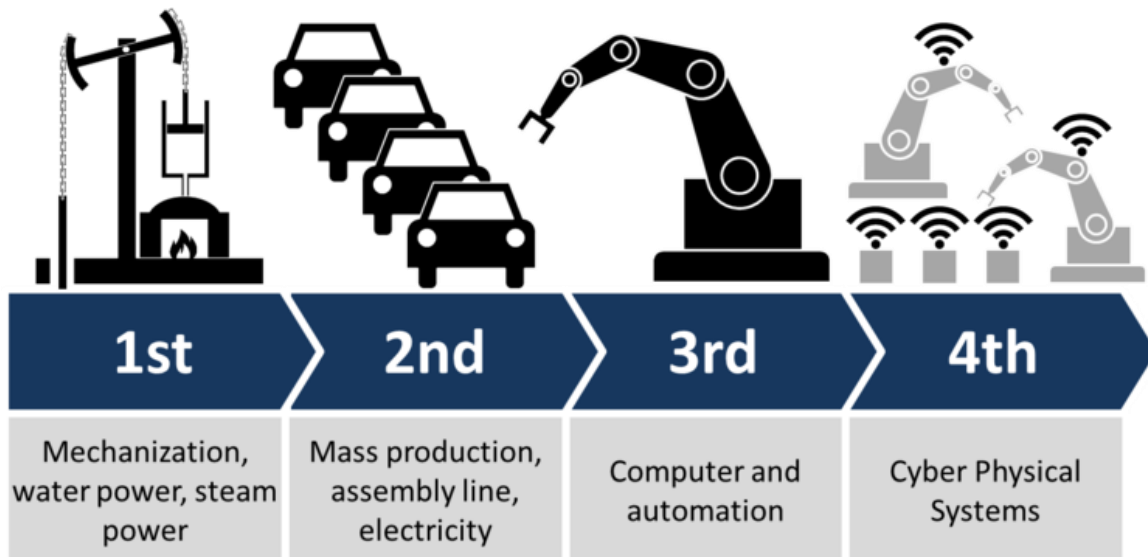
suffer from inability to string thoughts together such that they have a hard time forming sentences. I'm sure we've all experienced times in which our thoughts were difficult to control, or when we couldn't seem to come to conclusions about a given topic. Often, as I read my own writing, I find missed words and meanings. Clearly, my thought runs ahead of my banging on the keyboard keys. That said, fragmented thinkers may experience this as the norm in their lives.

2.5 What does it all mean?

Let's summarize the above before we move on. Both processes are equally important. Therefore, it's best to have both types of thinkers on a team. Or perhaps its fine to experience both types of thinking in your own mind, and to understand how and why both thought processes can be useful. Not that one can certainly force themselves to think a certain way. However, we can consciously put ourselves in positions that encourage certain types of thought. Need to get something done, a task for which you are sure of the starting point and the desired outcome? It may be worth your while to place yourself in an environment with few distractions and keep yourself on target.

3 Our world today

Today, we live in the Fourth Industrial Revolution. What does it mean? The First Industrial Revolution used water and steam power to mechanize production. The Second used electric power to create mass production. The Third used electronics and information technology to automate production. In a way, a Fourth Industrial Revolution is a continuation of the Third, the digital revolution that has been occurring since the middle of the last century. It is characterized by a fusion of technologies that is blurring the lines between the physical, digital, and biological spheres. The rate of change is breathtaking, millions, and, perhaps, billions, of people are instantly connected. We produce more information in an hour than we produced in couple of years just a hundred of years ago.



The artificial intelligence is all around us, from self-driving cars and drones to virtual assistants and software that translate or invest. Impressive progress has been made in machine learning and AI in recent years, driven by exponential increases in computing power and by the availability of vast amounts of data, from software used to discover new drugs to algorithms used to

predict our cultural interests. Digital fabrication technologies, meanwhile, are interacting with the biological world on a daily basis. Engineers, designers, and architects are combining computational design, additive manufacturing, materials engineering, and synthetic biology to pioneer a symbiosis between microorganisms, our bodies, the products we consume, and even the buildings we inhabit. In the very near future, humans may adapt characteristics of machines and visa versa.

Various predictions for the next several years suggest the following for the year 2025 or shortly thereafter:

1. \$1,000 should buy you a computer able to calculate at 10^{16} cycles per second (10,000 trillion cycles per second), the equivalent processing speed of the human brain.
2. The Internet of Everything describes the networked connections between devices, people, processes and data. By 2025, the IoE will exceed 100 billion connected devices, each with a dozen or more sensors collecting data. This will lead to a trillion-sensor economy driving a data revolution beyond our imagination. Cisco's recent report estimates the IoE will generate \$19 trillion of newly created value.
3. We're heading towards a world of perfect knowledge. With a trillion sensors gathering data everywhere (autonomous cars, satellite systems, drones, wearables, cameras), you'll be able to know anything you want, anytime, anywhere, and query that data for answers and insights.
4. Facebook (Internet.org), SpaceX, Google (Project Loon), Qualcomm and Virgin (One-Web) are planning to provide global connectivity to every human on Earth at speeds exceeding one megabit per second.
We will grow from three to eight billion connected humans, adding five billion new consumers into the global economy. They represent tens of trillions of new dollars flowing into the global economy. And they are not coming online like we did 20 years ago with a 9600 modem on AOL. They're coming online with a 1 Mbps connection and access to the world's information on Google, cloud 3D printing, Amazon Web Services, artificial intelligence with Watson, crowdfunding, crowdsourcing, and more.
5. Existing healthcare institutions will be crushed as new business models with better and more efficient care emerge. Thousands of startups, as well as today's data giants (Google, Apple, Microsoft, SAP, IBM, etc.) will all enter this lucrative \$3.8 trillion healthcare industry with new business models that dematerialize, demonetize and democratize today's bureaucratic and inefficient system.
Biometric sensing (wearables) and AI will make each of us the CEOs of our own health. Large-scale genomic sequencing and machine learning will allow us to understand the root cause of cancer, heart disease and neurodegenerative disease and what to do about it. Robotic surgeons can carry out an autonomous surgical procedure perfectly (every time) for pennies on the dollar. Each of us will be able to regrow a heart, liver, lung or kidney when we need it, instead of waiting for the donor to die.
6. Billions of dollars invested by Facebook (Oculus), Google (Magic Leap), Microsoft (Hololens), Sony, Qualcomm, HTC and others will lead to a new generation of displays and user interfaces.

The screen as we know it — on your phone, your computer and your TV — will disappear and be replaced by eyewear. Not the geeky Google Glass, but stylish equivalents to what the well-dressed fashionistas are wearing today. The result will be a massive

disruption in a number of industries ranging from consumer retail, to real estate, education, travel, entertainment, and the fundamental ways we operate as humans.

7. Artificial intelligence research will make strides in the next decade. If you think Siri is useful now, the next decade's generation of Siri will be much more like JARVIS from Iron Man, with expanded capabilities to understand and answer. Companies like IBM Watson, DeepMind and Vicarious continue to hunker down and develop next-generation AI systems. In a decade, it will be normal for you to give your AI access to listen to all of your conversations, read your emails and scan your biometric data because the upside and convenience will be so immense.

We are living through incredible times where the only constant is change, and the rate of change is increasing.

4 The State of Education

Incredibly, Education is the one aspect of our society that resist the change the most. Granted, the use of new technology is on the rise. Students, as young as 5, use all kinds of electronic gadgets in their daily activities. Yet, traditional education is very top-down, heavy-handed—sit down and read, be quiet, don't ask questions—leaves a lot to be desired. Innovation in the Education's content. Very few, and far in between, understand the difference between teaching and schooling. Schooling works on producing obedient citizens, soldiers and factory workers. Schooling is very linear in its approach. One must learn every subject in a step-by-step fashion. Just look at the way mathematics is taught. First, arithmetic, then algebra, geometry and trigonometry, then calculus, and so on. I introduced some 8 years old children to algebra and geometry concepts, before they learned the multiplication table, quite successfully.

Teaching, on the other hand, may be accomplished by various means, including, almost never used these days, self-study. Schools are very efficient in dumbing down otherwise smart children. It is only logical that in the US the number of homeschooled children grew from 50 thousand in 1980 to 2.5 million in 2015. And the trend only gets stronger with each passing year.

5 Why do we Need to be Concerned?

As was mentioned earlier, the rise in Machine Learning and AI present existential threat to humans. As predicted many years ago by reputable scientists, including G. S. Altshuller, machines will displace humans from workplace. We already enjoy the use of accounting and legal software. We use a computer screen to order food in a fast food restaurant. We make our travel reservations online. We shop without going to a store. In the USA alone we will lose some 5 million jobs by next year. We will develop some new ones, to be sure, but only 2 million. Then, the new jobs will require much higher level of the creative and critical thinking skills. The school doesn't teach those. The school forces students to memorize a whole bunch of information, then it tests their memory.

As a result, we are facing a huge social problem – society will be saddled with a huge number of people, who will need to be housed and fed, but who don't have sufficient marketable skills, enabling them to trade their time and effort for some pay. This is already a problem of today, not tomorrow or next year.

6 What needs to be done?

Let's look at Fig. 1, Life Span of a Professional Skill.

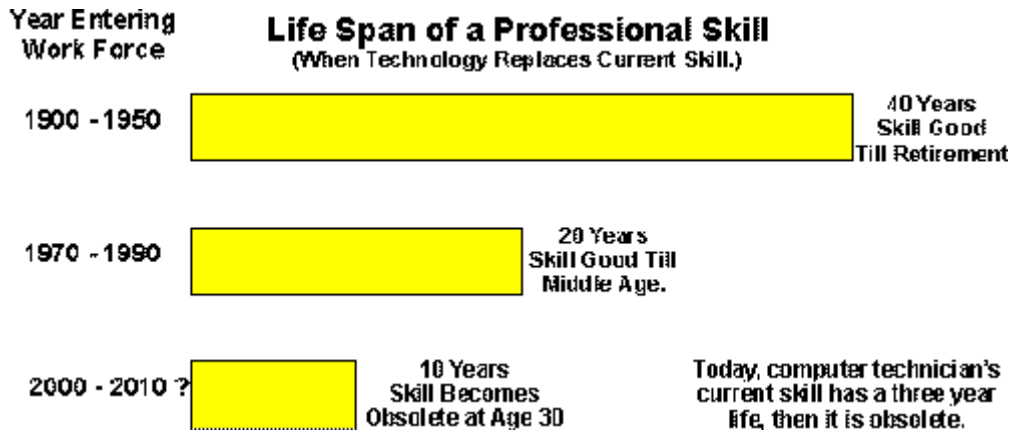


Fig. 1 Life Span of a Professional Skill

As you can see, we are in the age where we need to be able to remake our careers rather frequently. Or we may find ourselves lacking any marketable skills. Already today there are people in their 40s and 50s, too young to retire, who lost their jobs for various reasons and who can't find another job in their field of expertise. These people need to learn a new skill to claim a newly created job. In other words, they need to be able to qualify for a new occupation. Easier said than done! Today, we don't teach how to learn.

Leo Szilard, one of the prominent 20th Century physicist, offered an elegant analogy – if all societal knowledge may fit into a balloon of certain size, then we have the unknown around this balloon. When our knowledge grows into a larger size balloon, then so does the unknown. We add that every point on the perimeter of this balloon is a problem, which must be solved in order to expand our knowledge. From this follows – the more we know, the more problems our civilization requires.

Thus, a 21st century education is about giving students the skills they need to succeed in this new world and helping them grow the confidence to practice those skills. With so much information readily available to them, 21st century skills focus more on making sense of that information, sharing and using it in smart ways.

The skills for today as identified by P21 (Partnership for 21st Century Learning) are:

- Creativity
- Critical thinking
- Communication
- Collaboration

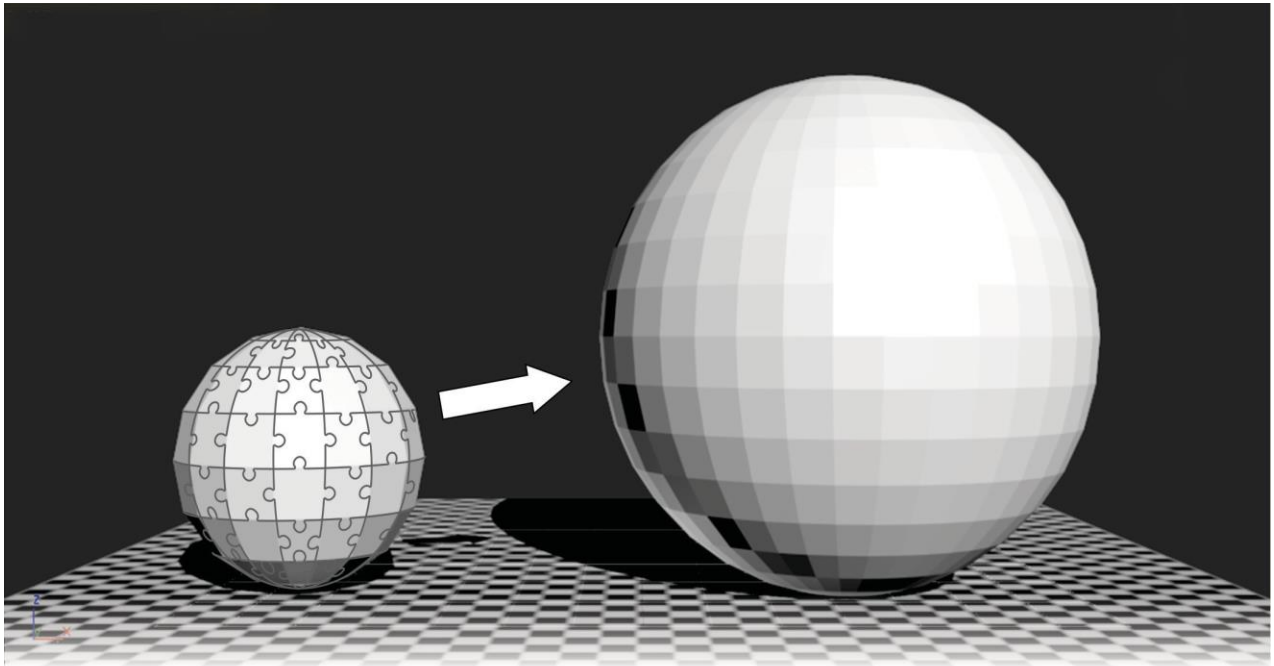


Fig. 2 Knowledge analogy

These four themes are not to be understood as units or even subjects, but as themes that should be overlaid across all curriculum mapping and strategic planning. They should be part of every lesson in the same way as literacy and numeracy.

Creativity is about thinking through information in new ways, making new connections and coming up with innovative solutions to problems. Critical thinking is about analysing information and critiquing claims. Communication is understanding things well enough to share them clearly with other people. Collaboration is about teamwork and the collective genius of a group that is more than the sum of its parts.

There are other skills that are important, which fall within these four areas. Entrepreneurship can be considered a skill of its own. Inquiry and problem solving are key. Emotional intelligence (EQ) is one of the most important keys to successful work and relationships. The bottom line? Education needs to be all about empowering students with transferable skills that will hold up to a rapidly changing world, not prescribed content that has been chosen for its past relevance.

7 Conclusion

There is no doubt in my mind – the World Educational System is in serious need of modification in order to meet the needs/demands of the 21st Century. It must be remade to serve the dynamic world we live in. Therefore, we need non-linear Educational System. We need not concern ourselves with schooling and test results. We need to concern ourselves with teaching creativity and critical thinking skills, foundation of success in the 21st Century. Creative and critical thinking skills may still put us at the advantage where machines are concerned. And we need to teach how to learn!

As we continue our journey through the Fourth Industrial Revolution, and beyond. As the job market becomes more fluid. As the technology becomes more and more advanced. Every new

graduate of the institution of tertiary education do themselves great favor by not looking to find a job but creating one for themselves.

As our knowledge grows, we need to nurture more and more problem solvers, capable of expanding our horizons.

References

1. A. Guin, M. Barkan: Success Factor, Oak Ridge, TN, USA 2015
2. Proceeds of World Economic Forum: Davos, Switzerland, 1/2016
3. A. Guin: School-Factory is Doomed. What's next? Education for a New Era blog, 2008
4. K. Robinson: A series of TEDx speeches and interviews
5. John Taylor Gatto: The Underground History of American Education; Oxford Scholars Press – New York, California, 2017
<http://www.businessdictionary.com/definition/divergent-thinking.html#ixzz4ChZnkGRQ>
6. A large number of internet sources on linear and non-linear thinking and education

Communication

Communicating Author: mbarkan@matriz.org

TRIZfest 2019

September 11-14, 2019. Heilbronn, Germany

TRENDS IN HEALTHCARE

Aljoscha Michael Flohr^a and Stefan Schaper^b

^a *Roche Diagnostics GmbH, D-82377 Penzberg, Germany*

^b *Schaper-Tech, D-82327 Tutzing, Germany*

Paper Classification:

- Theoretical, research results

Abstract

The Trends of Engineering System Evolution (TESE) are transferred to the healthcare environment. Healthcare systems are biological, chemical and mechanical systems with many special features and challenges. In previous analysis done by the authors the conventional trends have shown limitations for the use in life science so that the authors have decided to transfer the TESE to healthcare examples, wording and application.

1 Project

The healthcare industry produces pharmaceutical compounds (drugs), diagnostic tests, medical devices and services. The European pharmaceutical industry alone has spent in 2017 35 billion EUR for research and development of new drugs (**Statista 2019**). The development process for a new medication is time, labour and capital consuming. Similar procedures apply to diagnostic assays and medical devices, although expenses and revenues here are much lower.

As we deal here with complex biological systems of human beings several special conditions apply:

- The complexity of a “living system” is very high including many internal interactions
- We deal with living organisms who require special attention regarding safety, reliability, compliance, etc.
- The predictability of a “living system” is difficult as compounds may react differently than expected in creatures than in the laboratory and unforeseen side-effects may occur
- Proof of evidence “in living systems” must always be delivered by statistical methods and can rarely be derived deductively like in mechanics

- Biologists, Physicians and Chemists use different vocabulary and scientific approaches than engineers

2 TRIZ relation

The TESE are transferred and adapted to healthcare systems.

3 Results

We suggest a different wording from TESE to “Trends in Healthcare” at least in some cases. In other cases, the classical TESE were used but examples from the healthcare industry are suggested.

3.1 *Trend of Increasing Specificity (corresponds to Increasing Degree of Coordination)*

The trend of “increasing specificity of drugs” can be applied for the evolution of drug development in, e.g. oncology. This trend aims to avoid or at least limit side effects of drug treatment.

In the evolution of cancer drug treatment, chemotherapy can be considered as the first drug related therapeutic modality for cancer and it consists of cytotoxic reagents unspecifically targeting all cells. A significant step towards more specific treatment was the discovery and use of “targeted therapies” with, e.g. monoclonal antibodies, targeting, e.g. receptors on tumour cells specifically (example: Herceptin binds to HER-2, a growth factor receptor). The “targeted therapy” of cancer is combined with the classical chemotherapy but the overall treatment regimen has become more specific.

The actual ongoing trend in the treatment of human solid cancers are immuno-oncology approaches, e.g. checkpoint inhibitors (CTLA-4 inhibitors, PD-1 inhibitors, PD-L1 inhibitors), adoptive cell therapies (T-cell therapy or CAR T-cell therapy), and personalised RNA mutanome vaccines (Sahin U 2017), (Seetharamu N 2017), (Lipowska-Bhalla G 2012).

Among the above mentioned therapeutic modalities in oncology T-cell therapies and individualised mutanome vaccines are even more individualised than targeted therapies so that at least for these two therapeutic modalities the “trend of increasing specificity” holds true.

It is essential for pharmaceutical companies with a focus on innovative treatments in oncology to anticipate which immuno-oncology approach will be successful because it might well be possible that the most promising treatment approach will be the next S-curve and is therefore quite a significant business case.

3.2 *Trends of Individualization (Personalized Healthcare concept/ corresponds to Increasing Degree of Coordination 2nd part / Controllability)*

The trend of “increasing individualisation of the treatment regime” is closely related to the trend of “increasing specificity of drugs”: In the evolution of therapeutic modalities in, e.g. oncology drugs have become more specific, targeted, and customised for the patients in the past decades. This evolution refers to the trend of “increasing specificity of therapeutic modalities” (please refer also to 3.1).

The targeted therapy approach often includes a biomarker test stratifying patients in one subgroup of patients who have a benefit from the respective drug and in another subgroup of patients which has no benefit from the drug, e.g. breast cancer patients are only treated with the targeted drug “Herceptin” if their tumours are HER-2 positive as assessed by biomarker test(s).

Possible consequences of this trend are that the growing individualisation of therapeutic modalities and patient stratification for the corresponding treatment may lead to a decrease of prescription and sales of new exclusive drugs which are currently the most attractive business cases for pharmaceutical companies

- This may lead to an increase of the price of new targeted drugs so that pharmaceutical companies can compensate their sales
- A possible threat is the decrease of "drug blockbusters" in the future

Using personalized tumour models with similar characteristics to the original tumours may result in more accurate predictions of drug responses in patients (Hamidreza Aboulkheyr Es 2018).

3.3 Trend of Increasing Sensitivity

In diagnostic systems, e.g. immunoassays detecting a specific serum protein, a trend of increasing sensitivity is noticeable at least for some analytes. The increasing sensitivity can make sense for the detection of biomarkers if the intended use is affected in a positive way by increasing sensitivity. This can lead to earlier disease detection and maybe also to less fatality in some cases due to more sensitive tests (Bhattacharya S 2018), (Andrianaivoarimanana V 2019).

Possible business-related consequence of a more sensitive diagnostic test: the competitor with the more sensitive test in his portfolio may have a competitive advantage over competitors with a less sensitive test (depending on the respective intended use of the test).

3.4 Increasing Degree of Information and Digitalization

Although it could be considered as part of other trends like increasing flow, there is an overall increasing importance of information in healthcare systems:

- Increasing information to the patient
- Increasing information to the healthcare professional (Sharon Hewner 2018) (Navify 2019)
- *Examples*
 - There is an increasing degree of (digital) patient data in the hospital (e.g. patient diagnosis, imaging data, x-ray, computer tomography, MRT, laboratory data, pathology reports etc.). Some of this information is demanded by the patient or can be displayed to the patient in order to provide him additional services (e.g. 3D images of ultrasound of babies. In other cases, this data can be used to improve treatment (e.g. continuous blood glucose monitoring). Data can be displayed using existing devices (super system) like smartphones or dedicated systems like augmented reality (reference to trend of system completeness or controllability).
 - Algorithms that compute healthcare data like biomarker results to generate statistical probability of certain diseases (e.g. arterial fibrillation, GALAD score for hepatocellular carcinoma). These kinds of tools are used by physicians to improve diagnosis (Navify 2019).
- Increasing information to researchers (Nebion 2019)
- *Example*

- Use of curated databases to support research on new biomarkers (e.g. Nebion (Nebion 2019))
- Increasing information in production and other processes like logistics, regulatory, etc. (William J. Gordon 2018)
- *Example*
 - Today’s production processes in pharma and diagnostics are rigorously monitored by the healthcare authorities and patients demand transparency and traceability. This is more and more ensured by electronic batch records and other systems to ensure traceability and integrity of all components. At the same time demands for data safety and security are increasing (e.g. GDPR regulations). This concerns especially patient data and other personal information.
- Additional aspects like security of data is increasing with increasing use of data (Lynne Coventry 2018).

Although many useless applications exist it can generally be stated that additional information seems to be a new main parameter of value (MPV) for the patient, healthcare professional or the manufacturer of products.

3.5 Trend of Increasing Degree of System Completeness

The trend of increasing degree of system completeness refers to the fact that technological systems are built always by the components tool, transmission, source of energy and control.

If a certain component does not exist, it is taken from the environment which can include human beings. We have observed, that this trend is widespread, and it can be used for triggering ideas for digitization activities in healthcare or industry processes.

Example pipette in laboratory

System Component	Transfer Pipette	Automatic Pipette	Pipetting Robot
Tool	Pipette	Pipette tip	Pipette tip
Energy source	Human (fingers)	Motor / Human	Motor
Transmission	Human (arm)	Human (arm)	Mech. arm
Control	Human	Human	Computer

As a further example it can be mentioned that decision support systems are more and more preparing the medical decision making of physicians. Such systems include all relevant diagnostic data, DNA patterns of patients and other patient data to calculate scores which the physicians can use for their treatment decisions (Navify 2019).

3.6 Increasing Degree of Dynamization (classical naming according to TESE)

Dynamization is a relevant trend in many biological and chemical systems that support the improvement of manufacturing processes, diagnostic reagents or therapeutic modalities.

Example: “Extract substance from liquid”

- a) Comparable old method: filter paper (mechanical and porous structure)

- b1) Comparable new method with a higher degree of dynamization than a): HPLC (High Performance Liquid Chromatography): a porous column under pressure
- b2) Comparable new method with a higher degree of dynamization than a): Magnetic particles: porous particle absorb substance and get removed by a magnetic field

3.7 *Trend of Flow Enhancement (classical naming according to TESE)*

Flow in healthcare processes are typically very complex. This applies to biological and chemical manufacturing processes where many parameters influence the outcome of a recipe as well as in medical decision making. As many factors influence the outcome of a flow, the complexity is difficult to master. Furthermore, the regulatory systems don't encourage changes of approved processes. However, the need for increased efficiency and the competitive situation with more and more players selling generic drugs increase pressure drive the demand for improved flow.

Example "Logistic flow in clinical laboratory"

- Today technicians need to transport system reagents and samples to the analytical devices. Also, they need to remove waste in order to keep the system running. As the degree of logistical integration is currently low, the labs need to keep considerable stocks of reagents and consumables. Future systems will help to optimize stocks and automate flow of material and reagents to the analytical devices (Tiwari V. 2018).
- The last two decades have witnessed numerous advances in lab-on-a-chip platforms-based immunoassays (IAs). Such developed platforms comprise microfluidic chips, paper, lateral flow, cell phone, electrochemistry, and new biosensor concepts. There are novel immunoassay concepts and strategies for prolonged reagent storage and a significant progress in the achievement of next-generation automated, cost-effective, and easy-to-use immunoassays (Sandeep K. Vashist 2018).

3.8 *Transition to the Supersystem*

The resources of the environment can also be used for other purposes. These "super-system"-resources can be used to support diagnostic or treatment related functions. This can help to reduce complexity, save costs and improve patient experience.

Example "Blood sugar measuring devices"

- Diabetic patients need to carry a specific device to read out test stripes. Additionally, a puncturing device is required.
New approaches use the availability of smartphones. A dongle connects test stripe and smart phone which displays the information. Also, there are permanent sensors available which are attached to the skin and the data is also displayed and stored on the patients smartphone.
- Blockchain technology might facilitate this transition through several mechanisms: digital access rules, data aggregation, patient identity, and data immutability. A distributed ledger blockchain can be considered part of the supersystem as its "database" is distributed to multiple sites (William J. Gordon 2018).

3.9 *Increasing Degree of Trimming*

As healthcare and related chemical and biological systems are often complex, trimming is a very valuable approach. As all components influence each other and have often unknow side effects, it is challenging to perform trimming.

Example "Disposable pipetor tip"

A disposable pipetor tip is required to avoid contamination of samples.

Coated needle: no wetting possible so that no disposables are needed any more.

Micro droplets: no needle needed as droplets have the right size and can be measured in a precise way.

Also, an increasing degree of trimming can be observed to hospital processes, where standardization of treatments and also their compensation by the healthcare system is modified e.g. by the use of Diagnostic Related Groups (DRGs) (Carl Camilleri 2018). In DRGs, the reimbursement for certain diseases are based on a flat fee. For this reason, hospitals are interested in releasing patients as soon as they are healthy and have no interest in keeping them hospitalized as long as possible as in the past.

3.10 Uneven development of components

In many cases, the core technology of diagnostic or medical systems has not changed since many years. This trend is very pronounced in healthcare as the core technology is usually patent protected and companies tend to build hurdles to other competitors in order to use the technology as long as possible.

Example “Elecsys” automated immunoassay platform

The measuring unit of the ECL cell of the current “Elecsys e801” is the same as in the “Elecsys 2010” automatic immunoassay platform which was launched in 1996.

However, in contrast to the ECL cell other technical elements of the “Elecsys” system have been developed further from the model “Elecsys 2010” to “Elecsys e801”.

3.11 Trend of Increasing Value (classical naming according to TESE)

A relevant main parameter of value (MPV) for clinical laboratories is the number of tests per hour. Over the different versions of Cobas clinical Elecsys analysers from 1996 until today, the number of tests per hour has approximately been doubled with the same testing principle in the device:

- Elecsys 2010 (1996): 85t/h per cell
- cobas e 601 module (2001): 85 t/h per cell
- cobas e 801 module (2016): 170t/h per cell

The trend of increasing value also applies to the patient journey in hospitals, improved diagnostics and better medications.

The steady rise in the cost of healthcare coupled with the need for quality have combined to put the healthcare industry at the top of several national agendas. Quality, costs, and service are ongoing issues. They are critical for decision-making by patients, physicians, and many key constituents of healthcare organizations (Omachonu 2018).

3.12 Decreasing Degree of human involvement

As in other industries, the human labor is a very relevant factor for costs. At the same time, qualified medical expertise is extremely valuable. For these reasons, the human resources must be used as effective as possible although many healthcare systems are still behind other industries. In medical research due to regulatory factors there is also still need for improvement.

Example “Increasing use of robots and automatic warehouse systems in clinical laboratories”

- There will probably be automated warehouses in the future that can manage the placement of reagents to storage bins, manage stocks, material movements including automatic scanning and goods issue. Robots may also transport reagents to the analytical device. (Nilmini Wickramasinghe 2013)

3.13 Trend of Increasing Controllability (classical naming according to TESE)

The Trend of increasing controllability refers to systems controlling themselves more autonomously without or with little human intervention and reacting flexibly to certain parameters.

The below mentioned example illustrates the development of calibration procedures in laboratories.

Example “Calibration of lab devices”

- Uncontrolled: decision by any lab technician
- Fixed program: every day
- Fixed program with intervention: every day but a technician can stop it
- Externally controlled system: external system monitors parameters and requests calibration
- Self-controlled: device starts calibration when parameters are out of range
- See also (Fenton 2018) (Renata Paleari 2018)

4 Conclusions

The adaptation of TESE to “Trends in Healthcare” generally allows for the strategic use of TRIZ

- a) in the Healthcare Industry
- b) for healthcare professionals in hospitals

Employees in the Healthcare Industry and healthcare professionals would be new target groups for the strategic use of TRIZ:

- a) Trends are extremely important in this field as missing the next s-curve might be critical for long term existence of healthcare companies. Development times for new pharmaceutical compounds often exceed 10 years and require a huge amount of budget. The use of trends may support better strategic planning by, e.g. selection and focusing on the most promising future technologies.
- b) The “Trends in Healthcare” could help in this field to foster the “right strategic decisions” of the future development of hospitals and healthcare companies by anticipating new therapeutic modalities, innovative diagnostic tests, new methods and effective cost management models etc.

It is important to mention here that communication with healthcare and life science industry professionals is different compared to professionals in engineering environments. Due to complexity systems are fragmented and specialists for isolated areas of knowledge are dominant. Addressing them in the right wording and the right way is crucial.

References

1. Álvarez, Ricardo H. „Advanced breast cancer therapy: Present and future evolution of advanced breast cancer therapy.“ *Breast Cancer Research*, 22. October 2010 2010.
2. Andrianainivoarimanana V, Piola P, Wagner DM, Rakotomanana F, Maheriniana V, Andrianaliniana S, Chanteau S, Rahalison L, Ratsitorahina M, Rajerison M. „Trends of Human Plague, Madagascar, 1998-2016.“ *Emerg Infect Dis.*, Feb;25(2) 2019 Feb;25(2): 220-228.
3. Bhattacharya S, Goel G, George K, Shamsundar R, Lancy J, Sudarsana J, Devi S R, Sangeetha S, Kant K, Sathiyavathy K A, Sarada Devi K L, Rejitha K, Shailaja T S, Raveendran G, John AP, Sohanlal T, Varghese G, Madhavan A, Sen B, Suseela K V, Ahmed SM, Mathew. „Laboratory tests and clinical management of dengue in 26 healthcare institutions in India. 2018;20:5-13.“ *J Acad Clin Microbiol*, 2018; 20: 5-13.
4. Calibration of Fluidic Devices. Patent US20180231469A1. 2018.
5. Carl Camilleri, Mireia Jofre-Bonet, Victoria Serra-Sastre. „The suitability of a DRG casemix system in the Maltese hospital setting.“ *Health Policy*, 2018, Volume 122, Issue 11,: 1183-1189.
6. Daniel Sanghoon Shin, Antoni Ribas,. „The evolution of checkpoint blockade as a cancer therapy: what's here, what's next?.,“ *Immunology*, Volume 33,2015, : Pages 23-35, ISSN 0952-7915.
7. Hamidreza Aboulkheyr Es, Leila Montazeri, Amir Reza Aref, Massoud Vosough, Hossein Baharvand,. „Personalized Cancer Medicine: An Organoid Approach.“ *Trends in Biotechnology*, 2018 Volume 36, Issue 4,: Pages 358-371,.
8. Lipowska-Bhalla G1, Gilham DE, Hawkins RE, Rothwell DG. „Targeted immunotherapy of cancer with CAR T cells: achievements and challenges.“ *Cancer Immunol Immunotherapy*, 2012 , 7: 953-962.
9. Lynne Coventry, Dawn Branley. „Cybersecurity in healthcare: A narrative review of trends, threats and ways forward.“ *Maturitas*, 2018, Volume 113: 48-52.
10. Navify. kein Datum. <https://www.navify.com/tumorboard/> (Zugriff am 10. 06 2019).
11. Nebion. kein Datum. <https://nebion.com/> (Zugriff am 10. 06 2019).
12. Nilmini Wickramasinghe, Latif Al-Hakim, Chris Gonzalez, Joseph Tan. *Lean Thinking for Healthcare*. Springer, 2013.
13. Omachonu, Vincent K. *Healthcare Value Proposition Creating a Culture of Excellence in Patient Experience*. New York, 2018.
14. Renata Paleari, Ferruccio Ceriotti, Cornelis L. Harteveld, Marta Strollo, Greet Bakker-Verweij, Jeanet ter Huurne, Sharda Bisoen, Andrea Mosca,. „Calibration by commutable control materials is able to reduce inter-method differences of current high-performance methods for HbA2.“ *Clinica Chimica Acta*, 2018, Volume 477: 60-65.
15. Sahin U, Derhovanessian E, Miller M, Kloke BP, Simon P, Löwer M, Bukur V, Tadmor AD, Luxemburger U, Schrörs B, Omokoko T, Vormehr M, Albrecht C, Paruzynski A, Kuhn AN, Buck J, Heesch S, Schreeb KH, Müller F, Ortseifer I, Vogler I, Godehardt E, Attig S, Ra. „Personalized RNA mutanome vaccines mobilize poly-specific therapeutic immunity against cancer.“ *Nature*, 2017. 547: 222-229.
16. Sandeep K. Vashist, John H.T. Luong. *Handbook of Immunoassay Technologies*, Chapter 15 - Lab-on-a-Chip (LOC) Immunoassays. Academic Press, 2018.
17. Seetharamu N, Preeshagul IR, Sullivan KM. „New PD-L1 inhibitors in non-small cell lung cancer - impact of atezolizumab.“ *Lung Cancer (Auckl)*, 2017, 8: 67-78 .

18. Sharon Hewner, Suzanne S. Sullivan, Guan Yu. „Reducing Emergency Room Visits and In-Hospitalizations by Implementing Best Practice for Transitional Care Using Innovative Technology and Big Data.“ Sigma, March 2018.
19. Statista. 2019. <https://de.statista.com/statistik/daten/studie/70870/umfrage/pharmaindustrie-ausgaben-fuer-forschung-und-entwicklung/> (Zugriff am 10. 06 2019).
20. Tiwari V., Thakur R.S., Tiwari B. Optimization of EHR Data Flow Toward Healthcare Analytics. Springer, Singapore , 2018.
21. William J. Gordon, Christian Catalini. „Blockchain Technology for Healthcare: Facilitating the Transition to Patient-Driven Interoperability.“ 2018: 224-230.
- 22.

Communication

Communicating Author: aljoscha_michael.flohr@roche.com

TRIZfest 2019

September 11-14, 2019. Heilbronn, Germany

TRIZ ROADMAP FOR IDENTIFYING ADJACENT MARKETS

Oleg Abramov, Alexander Medvedev, Natalia Tomashevskaya

Algorithm Ltd., 16 Ruzovskaya Street, St. Petersburg, 190013, Russia

Paper Classification:

- TRIZ-related methods and tools development
- Case study

Abstract

Entering adjacent markets is a well-recognized and effective way of expanding a business without its dramatic transformation. Therefore, the identification of adjacent markets is a very popular service from TRIZ consultants. Modern TRIZ recommends using the reversed function-oriented search (RFOS) as a major tool for identifying adjacent markets for existing products. In practice, however, using RFOS is not always particularly straightforward, because (1) it is often necessary to find new markets / applications for technology and equipment involved in the production of a product, rather than for an existing product, and (2) the product itself may not be a separate product intended for the end user, but a component for some other product. However, RFOS is not the only useful TRIZ tool that can be used to identify new markets for existing products and technologies. Based on their practical experience in TRIZ consulting, the authors have developed a roadmap for identifying adjacent markets, which includes the analysis of Main Parameters of Value, Voice of the Product, screening based on the Quantum-Economic Analysis (QEA-screening) and other TRIZ tools, in addition to RFOS. The roadmap is applicable for all kind of products as well as for technologies involved in their production. Four brief case studies are presented to illustrate the use of the roadmap.

Keywords: *adjacent markets, AMI, main parameters of value, MPV analysis, QEA-screening, reversed function-oriented search, RFOS, TRIZ, voice of the product, VOP.*

1 Introduction

Entering adjacent markets is a widely accepted marketing strategy for developing business without venturing too far from the core competence of the company [1, 2]. Therefore, the demand for the services of TRIZ consultants in adjacent market identification (AMI) is growing rapidly.

In the marketing literature, however, it is difficult to find specific recommendations or a sufficiently detailed algorithm for identifying the adjacent markets. For example, VisionEdge Marketing [3] recommends performing the following steps:

1. List adjacent markets you are already serving.
2. List adjacencies your organization has previously considered or rejected.

3. Identify other existing adjacencies you know.
4. Consider what potential adjacencies might emerge due to a technology advancement.

These recommendations are too general to be instrumental and rely too much on the personal skills and experience of the implementer, which makes them difficult to use in practice and does not guarantee success.

TRIZ practitioners have developed more specific approaches to identify and address adjacent markets, but in most cases this is associated with developing a new product to serve adjacent customers who are not served by the core product of the company. Frequently, TRIZ consultants suggest to do the following: (1) generate ideas for new products, and (2) see if these products can serve some adjacent markets. For instance, Ball et al. [4] recommend using Systematic Inventive Thinking (SIT) tools proposed by Boyd and Goldenberg [5] in order to generate ideas for new products and then to identify others who may need these new products, apart from existing customers.

This method is in fact a type of trial and error approach, which requires a good deal of time and labor, but does not guarantee that adjacent markets will be found. Additionally, most companies would prefer not to develop new products, but to enter adjacent markets with their existing product and assets.

This demand is partially addressed by GEN TRIZ methodology for AMI [6] that represents a Reversed Function-Oriented Search (RFOS). RFOS generally includes the following main steps:

1. Select an object for RFOS, which could be the entire product/technology or one of its components.
2. Formulate all properties of the object (physical, chemical, geometrical, etc.) and select one of the properties.
3. Convert the selected property to a set of functions and select one of the functions.
4. Generalize the selected function and identify a leading area in which similar functions and properties are very important and that has the biggest business potential.
5. Identify in the selected area a specific function similar to the generalized function and use the identified function as a new main function of the initial object.
6. Identify and solve adaptation problems to make the object perform the new main function.

Although RFOS does provide a systematic approach to identifying adjacent markets, its application is not always straightforward.

First, the leading areas that RFOS suggests to identify at Stage 4 (see step 4 in the list above) are not defined for the case when AMI is performed for a consumer product. The term “leading areas” used in RFOS came from classical Function Oriented Search (FOS) introduced by Litvin [7], which is designed for industry and science, and is hardly applicable to the consumer market.

This means that RFOS can only be applied to AMI for business-to-business (B2B) products, but even in this case it does not give specific recommendations on selecting the leading areas, nor on assessing which of the leading areas offer maximum business potential to the client. In practice, this results in considering more leading areas than necessary, spending extra time and resources.

Second, RFOS does not provide specific recommendations on how to select the object for RFOS and how to select one of its properties to convert to a set of functions, which often results in the necessity to repeat the entire procedure several times in order to consider several different properties.

Finally, RFOS does not specify how to convert the properties of the objects into functions, which may be a difficult task, for example, if the object of RFOS is a chemical substance/ingredient.

In this paper, the authors summarize their experience in identifying adjacent markets for different clients and come up with an RFOS-based roadmap for AMI that is easier to use than the original RFOS [6]. The focus of this paper is shown on the Innovation Ambition Matrix [1], see Fig. 1.

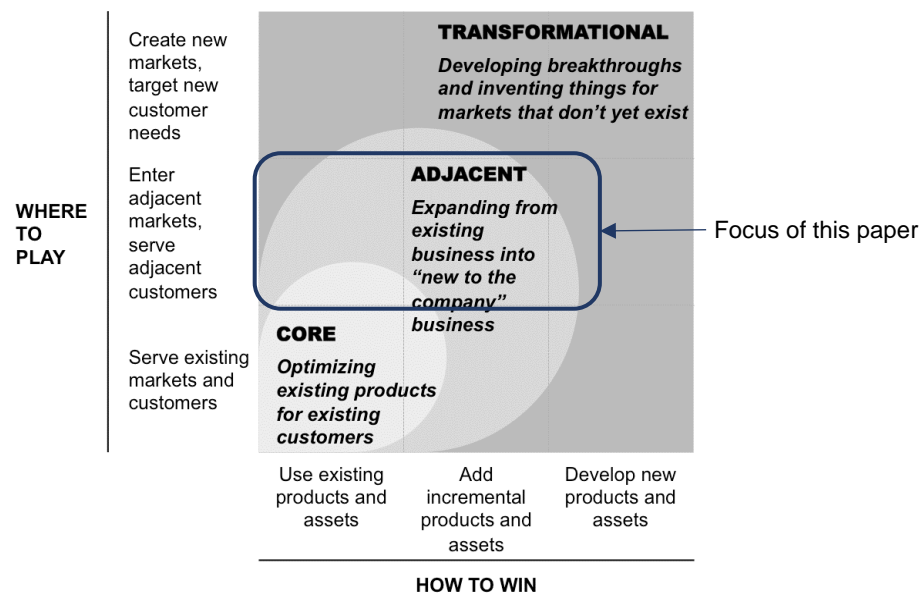


Fig. 1. Innovation Ambition Matrix [1] and the focus of this paper

As can be seen from Fig. 1, the paper mainly covers the identification of those adjacent markets into which you can enter with existing products and assets (such as technology and equipment) or with only incremental modification of existing products and assets. In fact, this is the most frequent request in TRIZ consulting practice.

2 Method: TRIZ tools utilized

In order to make the roadmap for AMI as specific as possible, we used existing tools of modern TRIZ in order to enhance RFOS. These tools are:

- Main Parameters of Value (MPV) analysis, as summarized by Litvin [8], which helps to identify “leading areas” (that is leading demands) of the consumer market. This includes the approach for identifying latent customer needs described by Ikonen [9].
- Voice of the product (VOP), as described by Abramov [10], that identifies the most promising MPVs (properties and functions) that the product may offer to consumers, including the product’s latent MPV, as shown by Abramov [11].

- Screening tool utilizing Quantum Economic Analysis (QEA), introduced by Abramov et al. [12-13] (further in this paper referred to as QEA-screening). This tool identifies leading areas that are unpromising for the client's business, and should be rejected.

3 Results

The resulting roadmap that the authors suggest for AMI projects is shown in Fig. 2.

It should be noted that this roadmap assumes that the object for which it is necessary to find adjacent markets has already been selected, which is, in fact, almost always the case in the practice of TRIZ consulting.

Indeed, the roadmap in Fig. 2 does not cover all cases when it is necessary to utilize adjacent markets. For example, it does not include the use of, as suggested by Hagel et al. [16], assets available on adjacent markets, e.g., Uber's use of automobiles that are owned by others.

The authors, however, have successfully applied all parts of this roadmap in several actual AMI projects. The highlights of these projects are given in the brief cases studies below.

3.1 Case study 1: AMI for beta-glucan

In this project, the client was a medium-sized company producing baking yeast. As a by-product, the company obtains beta-glucan, a biopolymer with high nutritional value, which is a popular food additive. However, the amount of beta-glucan produced by the company exceeded demand in the local food industry and, so, the company was looking for adjacent non-food markets for this by-product.

The product-oriented MPV analysis [11], which we performed at the molecular level, showed that beta-glucan molecules have, the following features:

- They are able to promote gelling, and
- They have an internal cavity in which they are able to trap and hold foreign molecules.

These features can be translated into generalized functions "to thicken" liquids, and "to absorb" liquid or gas.

Examples of leading areas that need these functions most are: the concrete industry, geo-engineering, and the pharmaceutical industry.

Therefore, the new applications for beta-glucan that we recommended to the client included:

- Using beta-glucan as a viscosity agent in concrete that allows improving important properties of concrete without adding more cement as confirmed by Nara et al. [17];
- Using beta-glucan as a soil-strengthening component that, when sprayed over the soil, makes the soil stronger, thereby preventing its erosion, as researched by Chang and Cho [18];
- Using beta-glucan in the pharmaceutical industry as a drug encapsulation agent that is able to efficiently hold and deliver molecules of medications into the human body as indicated by Venkatachalam et al. [19].

QEA-screening revealed that for a medium-sized company, which our client is, all three of these applications are promising in terms of commercialization potential, while a few other applications that we found (not mentioned here) are much less promising for the client's business.

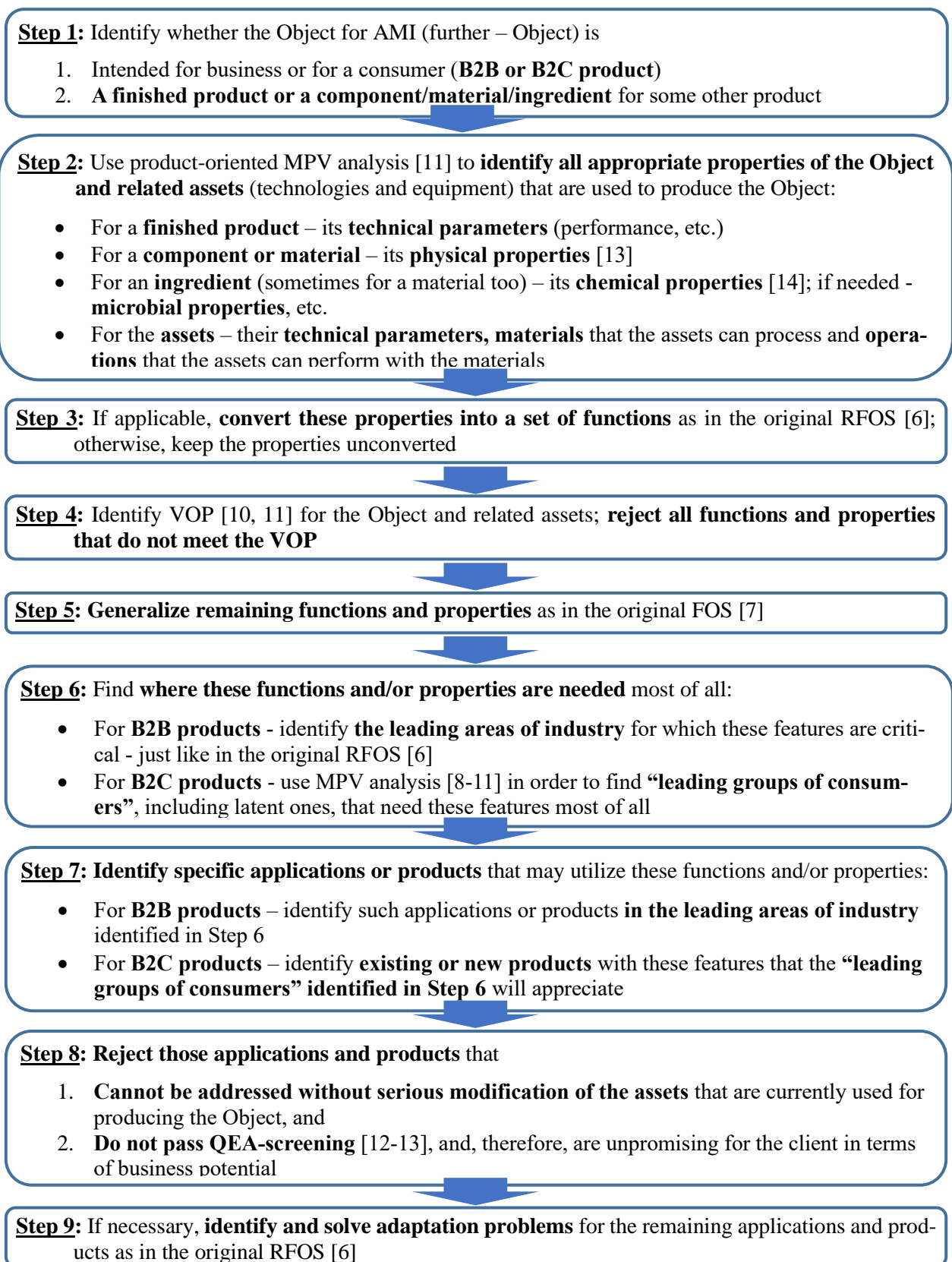


Fig. 2. TRIZ roadmap for identifying adjacent markets

3.2 Case study 2: AMI for tin cans

The client in this case was a medium-sized producer of tin cans for the food and paint industries. Unfortunately, the local food and paint markets were not large enough, while the international market for tin cans was becoming more and more competitive, and therefore difficult for the client to penetrate and hold onto. For these reasons, the client wanted to discover adjacent markets for tin cans.

The product-oriented MPV analysis and the VOP [10, 11] for tin cans showed that

- Cans have some properties, for example, buoyancy, that are not utilized in their current application as a container for protecting products during storage and transportation;
- Consumers have latent MPVs that are not addressed by existing cans, for example, consumers would like the contents of the tin can not to stick to the can's walls in order to use 100% of the product. Currently, large amounts of the contents (especially paint) remain on the can's walls.

These two properties can be converted into the following generalized functions: "to float in the liquid" and "to repel substances," respectively.

One of the leading areas for floating objects is the fishing industry, where large amount of floats are used for fishing nets; the leading area for anti-stick cans is the paint industry, which the client currently underserves with its existing cans.

Based on this, among the over 40 new applications for tin cans that we recommended to the client were:

- Using tin cans as floats for fishing nets (adjacent market is fishing net industry), and
- Making oleophobic cans, for example, by treating them with an omniphobic coating by UltraTech [20]. This may allow the client to win a good piece of the paint market currently served by competitors.

QEA-screening revealed that for a medium-sized company both of these applications are promising in short to mid-term prospective.

3.3 Case study 3: AMI for used batteries

We performed this project for a large company that produces zinc-carbon battery cells for portable electronics. In order to protect the environment, the company accepts used batteries and, after crushing these batteries, obtains a black powder containing a mixture of carbon and metal oxides particles (mostly zinc and manganese oxides). Then, the company just stores the powder in special warehouses. There are two reasons for this: 1) the government forbids disposing the powder into the environment and 2) there are no known methods for recovering valuable metals (zinc and manganese) from the powder that are economically feasible. So, the company was looking for useful applications for the black powder as it is or for its components that can be separated without involving expensive technologies.

Examples of the black powder properties revealed by our MPV analysis are:

- Black color, and
- Electric conductivity.

We converted these properties into the following generalized functions: "to make black" and "to conduct electric current", respectively.

These functions are needed in the following applications that we recommended to the client:

- Using in the manufacture of black bricks as suggested by Hyong Hag Im [21], in which black powder is used as a coloring agent for clay bricks, and
- Using black powder as a conductive additive for different materials.

QEA-screening revealed that for a medium-sized company these applications are promising in short to mid-term prospective.

3.4 Case study 4: AMI for automotive rubber parts

In this project, the client was a medium-sized company that produces different types of moulded and extruded rubber parts for the automotive industry: hoses, bellow, seals, gaskets, etc. The local market for these parts had become saturated and the company wanted to identify adjacent markets and the products for these markets that it could produce using its existing assets, which included technologies and equipment for moulding and extruding items out of different elastomer compounds.

Our MPV analysis showed that elastomers have some properties that the products currently produced by the client did not utilize, for instance:

- High dielectric strength;
- High thermal conductivity, etc.

We converted these properties into the following generalized functions: “to stop electric current” and “to conduct heat”, respectively.

These functions are critical for the following applications/products, among numerous other new applications that we had found, that we recommended to the client:

- Various insulators for medium- and high-voltage electrical grids;
- Heat conductive pads for electronic components, such as processors, power transistors, etc.

QEA-screening revealed that these applications are promising for the client in short to mid-term prospective, while some of the other new applications that we had found were not so promising for a medium-sized company like our client.

4 Conclusions

This paper describes research in progress and, so, the roadmap for identifying adjacent markets presented here, although it was very useful in actual TRIZ-consulting projects performed by the authors, cannot be considered as a universal roadmap that works equally well in all practical cases.

The roadmap does, however, cover the most frequent practical cases when the client wants to introduce its current product to adjacent markets or to use its existing assets to serve these markets.

As compared to the original RFOS [6], the proposed roadmap provides

3. Much more specific and detailed recommendations for most steps, which saves time and resources in the project;

4. Higher value results because it rejects unpromising products/applications for adjacent markets that either do not meet VOP or are unlikely to be commercialized by the client.

Acknowledgements

The authors would like to thank Deborah Abramov, for her helpful comments and for editing this paper.

References

1. MBA Knowledge Base. "The Innovation Ambition Matrix." Available: <https://www.mbaknol.com/strategic-management/the-innovation-ambition-matrix/>, accessed March 10, 2019.
2. Zook C., Allen J. "Profit from the Core: Growth Strategy in an Era of Turbulence." Harvard Business Review Press, 1st edition, 2001.
3. VisionEdge Marketing. "Market Strategy: How To Identify, Assess and Choose Adjacencies Wisely." Available: <https://visionedgemarketing.com/market-expansion-strategy-choose-adjacencies-wisely/>, accessed March 14, 2019.
4. Larry Ball et al., "TRIZ Power Tools. Discovering Markets." May 2015 Edition. Available: http://www.opensourcetriz.com/images/1_OpenSourceTRIZ_Pictures/11_Discovering_Markets/Discovering_Markets.pdf, accessed March 10, 2019.
5. Boyd D., Goldenberg J. "Inside the Box: A Proven System of Creativity for Breakthrough Results." New York, Simon & Schuster, 2013.
6. GEN TRIZ, LLC. "Case Study: Adjacent Market Analysis." GEN TRIZ Web site. <https://www.gen-triz.com/case-study-adjacent-market-analysis>, accessed March 10, 2019.
7. Litvin S.S. "New TRIZ-Based tool Function-Oriented Search (FOS)". The TRIZ Journal, August 2005. [Online]. Available: <http://www.triz-journal.com/new-triz-based-tool-function-oriented-search-fos/>, accessed March 20, 2019.
8. Litvin S.S. "Main Parameters of Value: TRIZ-based tool connecting business challenges to technical problems in product/process innovation". 7th Japan TRIZ Symposium, September 9, 2011. Available: [http://www.triz-japan.org/PRESENTATION/sympo2011/Pres-Overseas/EI01eS-Litvin_\(Keynote\)-110817.pdf](http://www.triz-japan.org/PRESENTATION/sympo2011/Pres-Overseas/EI01eS-Litvin_(Keynote)-110817.pdf), accessed March 11, 2019.
9. Ikovenko S. "Identifying latent customer needs using TRIZ". PowerPoint presentation for the workshop at the 2nd International Conference on Systematic Innovation (ICSI), Shanghai, China, 2011.
10. Abramov O.Y. "'Voice of the Product' to supplement 'Voice of the Customer'". The TRIZ Journal, Jan 11, 2017. Available: <https://triz-journal.com/voice-of-the-product-to-supplement-voice-of-the-customer/>, accessed March 11, 2019.
11. Abramov O.Y. "Product-oriented MPV analysis to identify Voice of the product". Proceedings of TRIZFest-2016 Conference, Beijing, People's Republic of China, July 26-28, 2016, pp. 231-243. Available: <https://matriz.org/wp-content/uploads/2017/01/TRIZfest-2016-Conference-Proceedings.pdf>, accessed March 11, 2019.
12. Abramov O.Y. "Generating New Product Ideas with TRIZ-derived 'Voice of the Product' and Quantum-Economic Analysis (QEA)". Journal of the European TRIZ Association, IN-NOVATOR, ISSN 1866-4180, 02/2017, vol. 04, pp. 80-87. Available: <http://www.etria.eu/innovator/ETRIAJournal2017vol04.pdf>, accessed April 03, 2019.

13. Abramov O., Markosov S., Medvedev A. “Experimental Validation of Quantum-Economic Analysis (QEA) as a Screening Tool for New Product Development.” In: Koziółek S., Chechurin L., Collan M. (eds) *Advances and Impacts of the Theory of Inventive Problem Solving*. Springer, Cham, pp. 17-25, First online 30 November 2018.
14. “Physical property.” (2018) Wikipedia: The Free Encyclopedia, Wikimedia Foundation Inc. Available: https://en.wikipedia.org/wiki/Physical_property, accessed March 23, 2019.
15. “Chemical property.” (2018) Wikipedia: The Free Encyclopedia, Wikimedia Foundation Inc. Available: https://en.wikipedia.org/wiki/Chemical_property, accessed March 23, 2019.
16. Hagel J., Brown J.S., Wooll M. and De Maar A. “Unlock assets from adjacent markets.” Deloitte Insights, February 12, 2016. Available: <https://www2.deloitte.com/insights/us/en/focus/disruptive-strategy-patterns-case-studies/disruptive-strategy-unlock-assets-adjacent-markets.html>, accessed March 12, 2019.
17. K. Nara et al. “Properties of β -1, 3-Glucan (Curdlan) Applied for Viscosity Agent to Concrete.” *Concrete Research and Technology*, 1994, Vol. 5, Issue 1, pp. 23-28. Available: https://www.jst-age.jst.go.jp/article/crt1990/5/1/5_23/_article/-char/en, accessed March 30, 2019.
18. Chang I., Cho G. “Strengthening of Korean residual soil with beta-1,3/1,6-glucan biopolymer.” *Construction and Building Materials*, #30, June 2012, pp. 30–35. Available: https://www.researchgate.net/publication/257388701_Strengthening_of_Korean_residual_soil_with_beta-1316-glucan_biopolymer, accessed March 30, 2019.
19. G. Venkatachalam et al. “Cyclic β -Glucans from Microorganisms”. *SpringerBriefs in Microbiology*, 2013, pp. 17-19. Available: https://www.springer.com/cda/content/document/cda_download-document/9783642329944-c2.pdf?SGWID=0-0-45-1349844-p174603525, accessed March 30, 2019.
20. UltraTech International, Inc. “Omniphobic Coatings & Products.” UltraTech Web site. <https://www.spillcontainment.com/categories/omniphobic-coatings-products/>, accessed March 31, 2019.
21. Hyong Hag Im (2007). “Method for making ceramic-coloring clay bricks using waste batteries powder.” European Patent EP2114646B1. Available: <https://patents.google.com/patent/EP2114646B1/en>, accessed April 17, 2019.

Communication

Communicating Author: Oleg.Abramov@algo-spb.com

TRIZfest 2019

September 11-14, 2019. Heilbronn, Germany

TRIZ - TIME AND FAULT TREE ANALYSIS WITH FUNCTION ANALYSIS

Jochen Wessner

Esslingen, 73728, Germany

Paper Classification:

- TRIZ-related methods and tools development

Abstract

The paper proposes an enhancement of function analysis to display a time context within the graphical model of this analytical tool. A combination of Fault Tree Analysis (FTA) and function analysis can help checking for missing functions and functional inconsistencies. Both approaches are shown for the system of a household tea press. This way of modelling a system leads to the advantages of a clear and easy to understand structure of the system hierarchy, the associated function models and the time frames to which the models belong. The quality of the results of both analytical tools improves due to the crosschecking. If needed short sequences could be built. Furthermore, I am very thankful to Dr. Robert Adunka for his time and valuable comments.

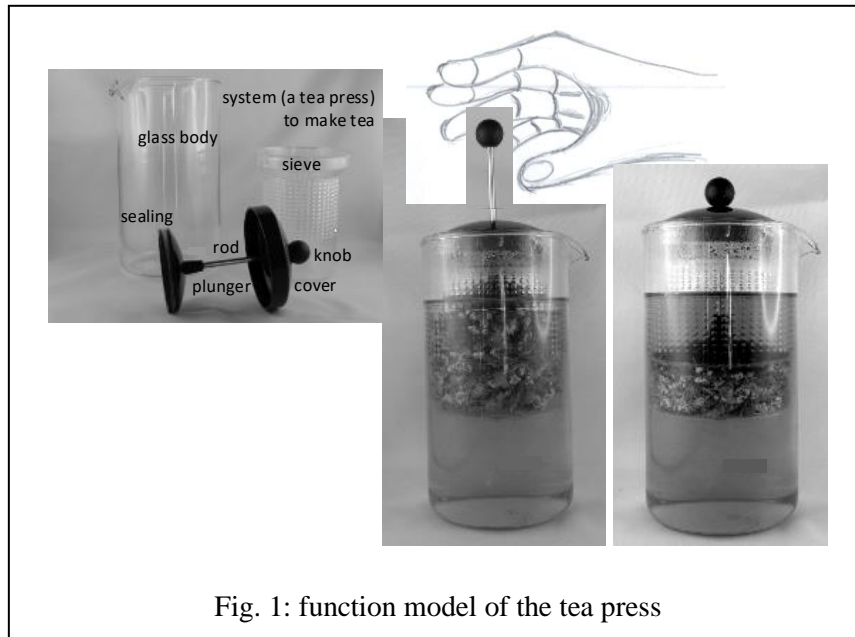
Keywords: *function analysis, system hierarchy, time, fault tree analysis.*

1 Introduction

Technical systems develop in the direction of increased ideality [1] and function analysis is an important TRIZ tool to analyse systems. Function analysis contains three parts, component analysis, interaction analysis and the functional table. In the first part the system and its boundaries is defined. After the completion of an interaction analysis the function table is filled in. From this table a graphical representation can be derived [2, 3]. The graphical representation is very useful to get an immediate overview of the system. This is carried out for one specific time, usually the time a certain problem arises. The focus on this problem time might lead to an optimisation for this step only. The following paper deals with the integration of many time steps and Fault Tree analysis into function analysis. These enhancements offer the opportunity to display present problems in all time steps and improve the integrity and usability.

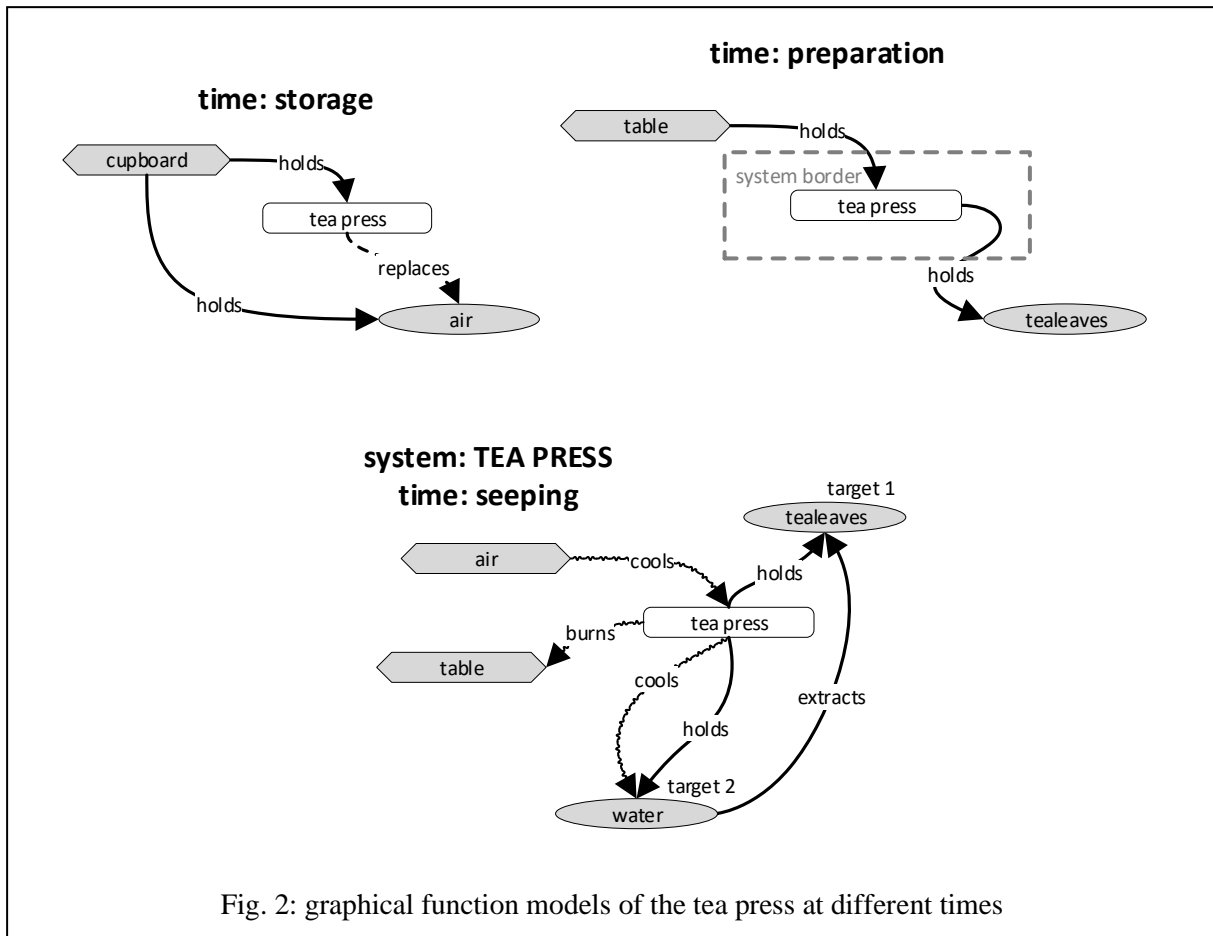
2 Fault Tree Analysis (FTA) and Time with Function Analysis

The application of time stamps within a function model in form of a table was presented in [4] by Feygenson and Litvin. At the TRIZfest 2017, a graphical model with three time steps was shown in [5] in which the shapes of the components were modified to the form of an hourglass and the times beginning, middle and post were introduced. Illustrating the proposed approach the technical system, a tea press, is considered, which consists of a glass body, a plastic sieve and a press assembly. The press assembly contains a cover, a rod, a knob and a plunger on which a sealing is mounted. Figure 1 shows the system together with the main useful function.



The main useful function of the tea press is to make tea. This is the reason why the system is present and it is quite common in many households. For functions to be present there has to be interaction and interaction can take place if the components touch each other. There is interaction (touching) of the glass body with the sieve and of sieve with the cover. The sieve touches the cover, the sealing and the plunger. The cover touches the rod. This leads to the following holding and guiding functions. The glass body holds the sieve. The sieve holds the cover and guides the sealing and the plunger.

The cover guides the rod. The main useful function and the associated target change due to the time and the hierarchical level of the analysed system. For example, the main useful function during storage is to remove as less air in the kitchen cupboard as possible and for the preparing stage the holding of the tealeaves.



At the top of figure 2, these two different times are illustrated. Due to the aspect of time, we can see at once that the system of the tea press has different targets or function objects at different times. We now proceed to the seeping process (see figure 2 down). The hot water becomes an additional target. The zooming-in process is illustrated at the time of moving the knob down by the user to stop the seeping process and obtaining the intended product, i.e. the tea. In figure 3 the top left picture shows the system at a time prior to the moving. On the right, the user is moving the knob. The system of the tea press is split up into its main three components, the glass body, the sieve and the press assembly. The press assembly is zoomed-in once more, i.e. the cover, rod, knob, sealing and plunger are now present. The system hierarchy has changed. The focus is transferred to the sub-system of the press assembly. On this level, the sieve and the glass body now become super system components and the tealeaves are the new target. To focus on that system all super system components with connections just to themselves are removed. Figure 4 shows the result of this reduction of the system complexity.

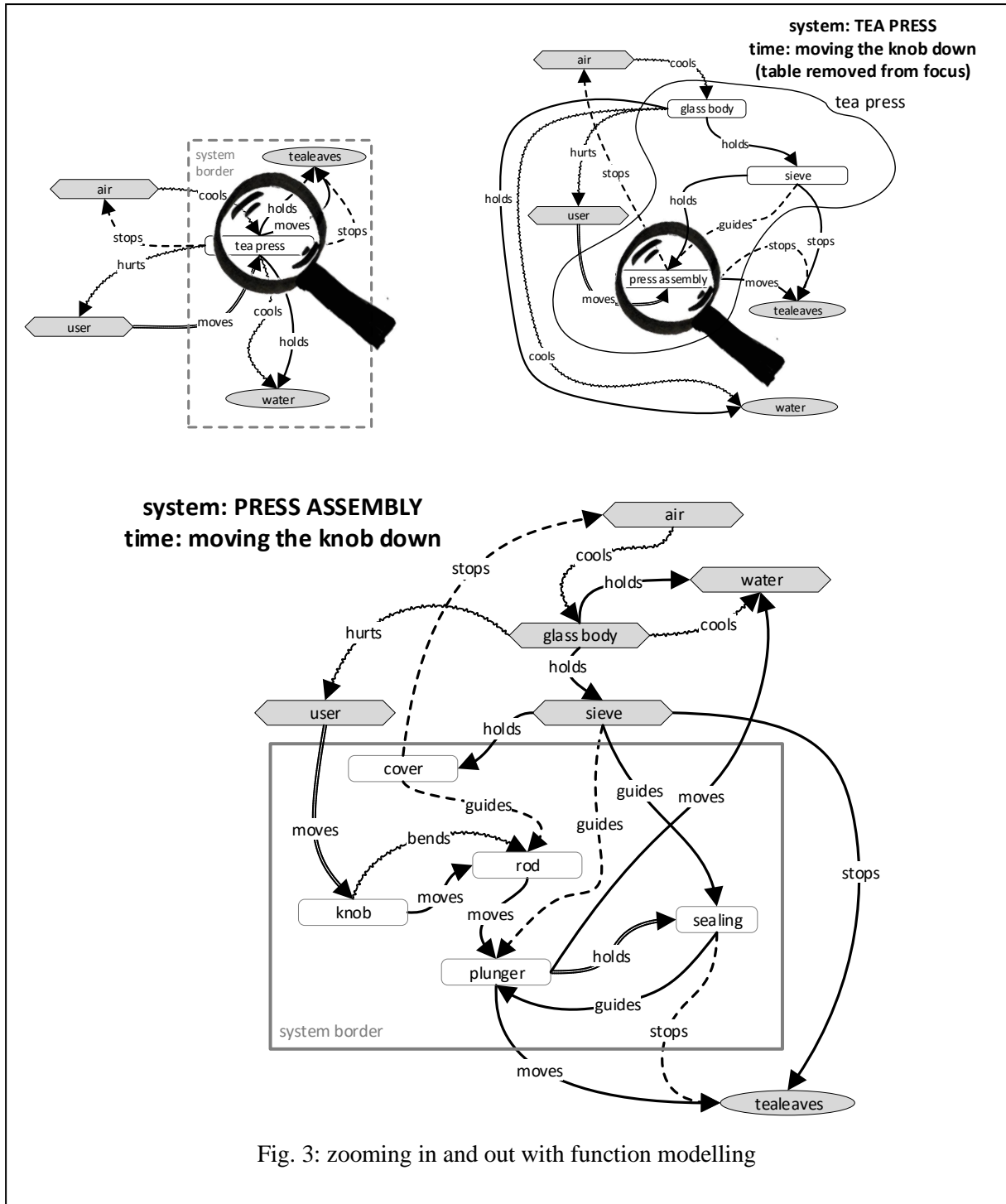
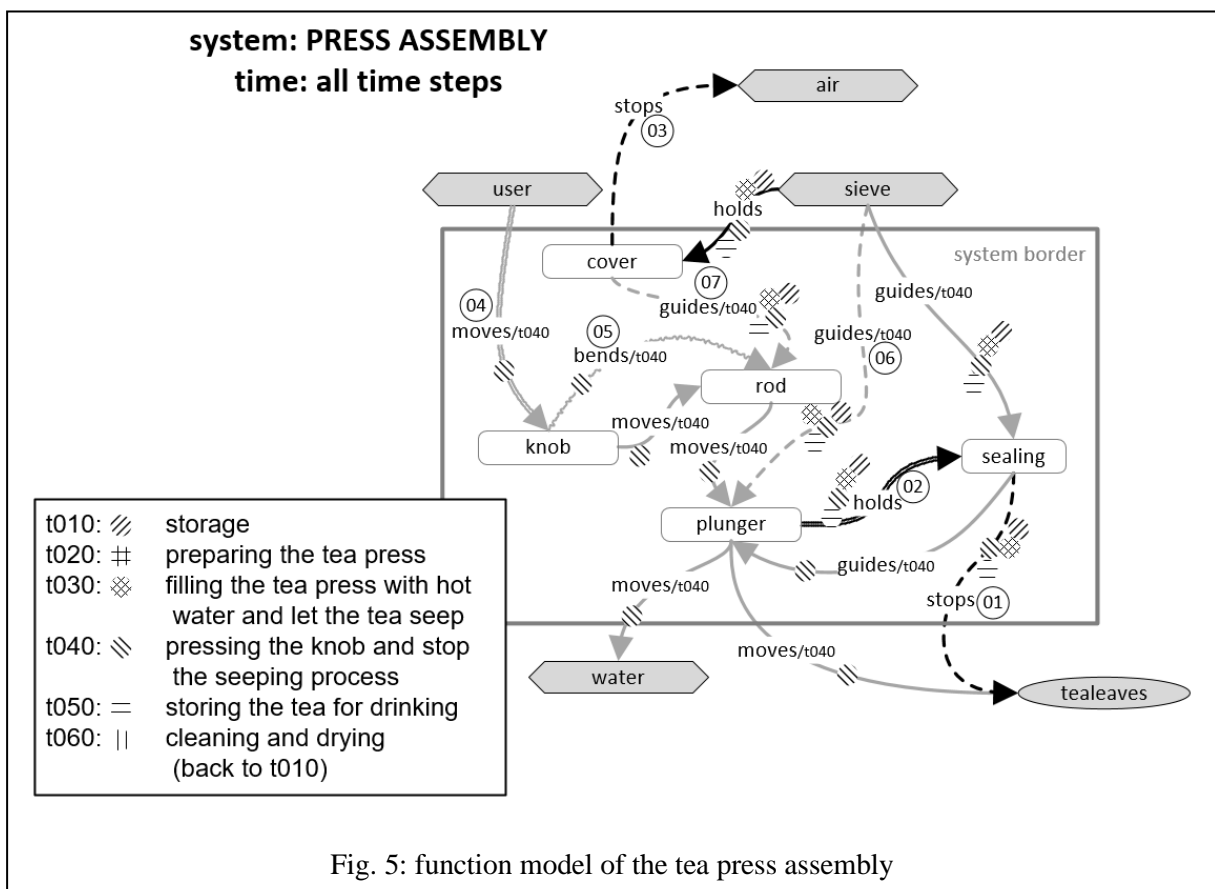
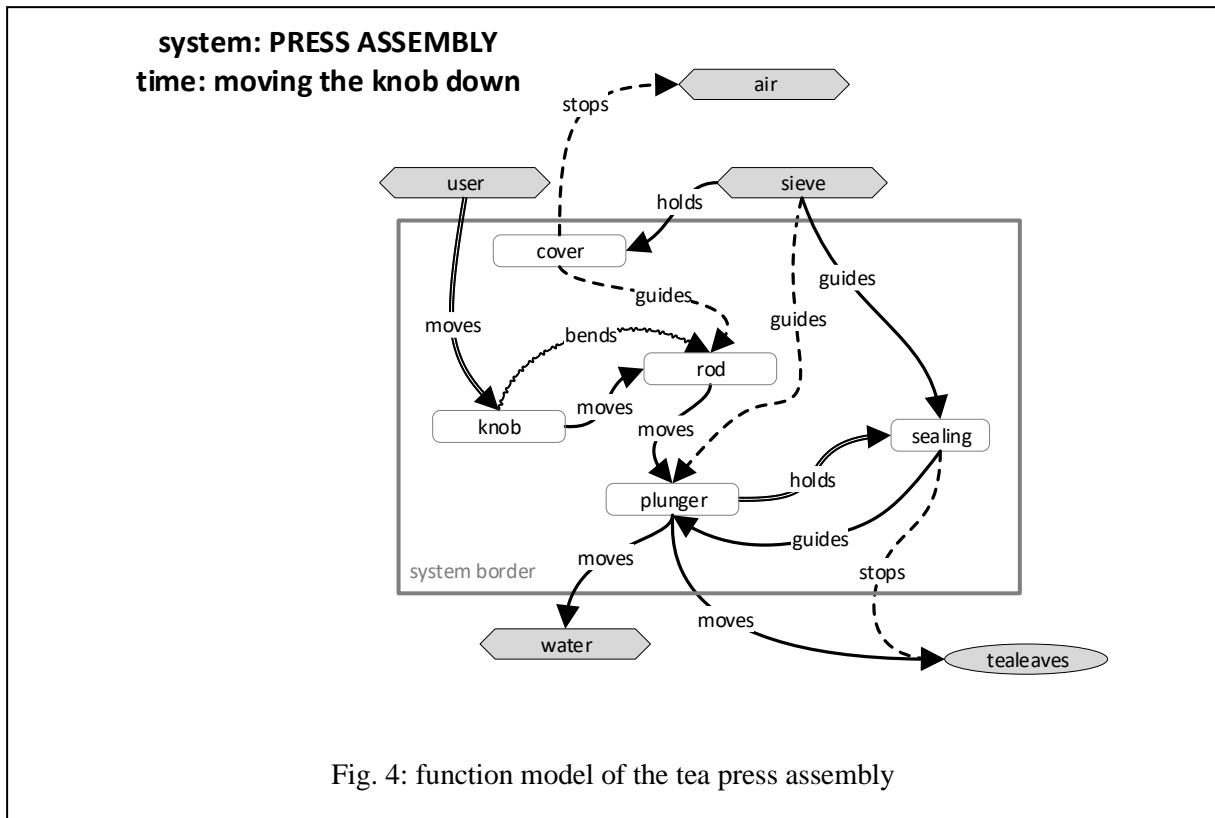
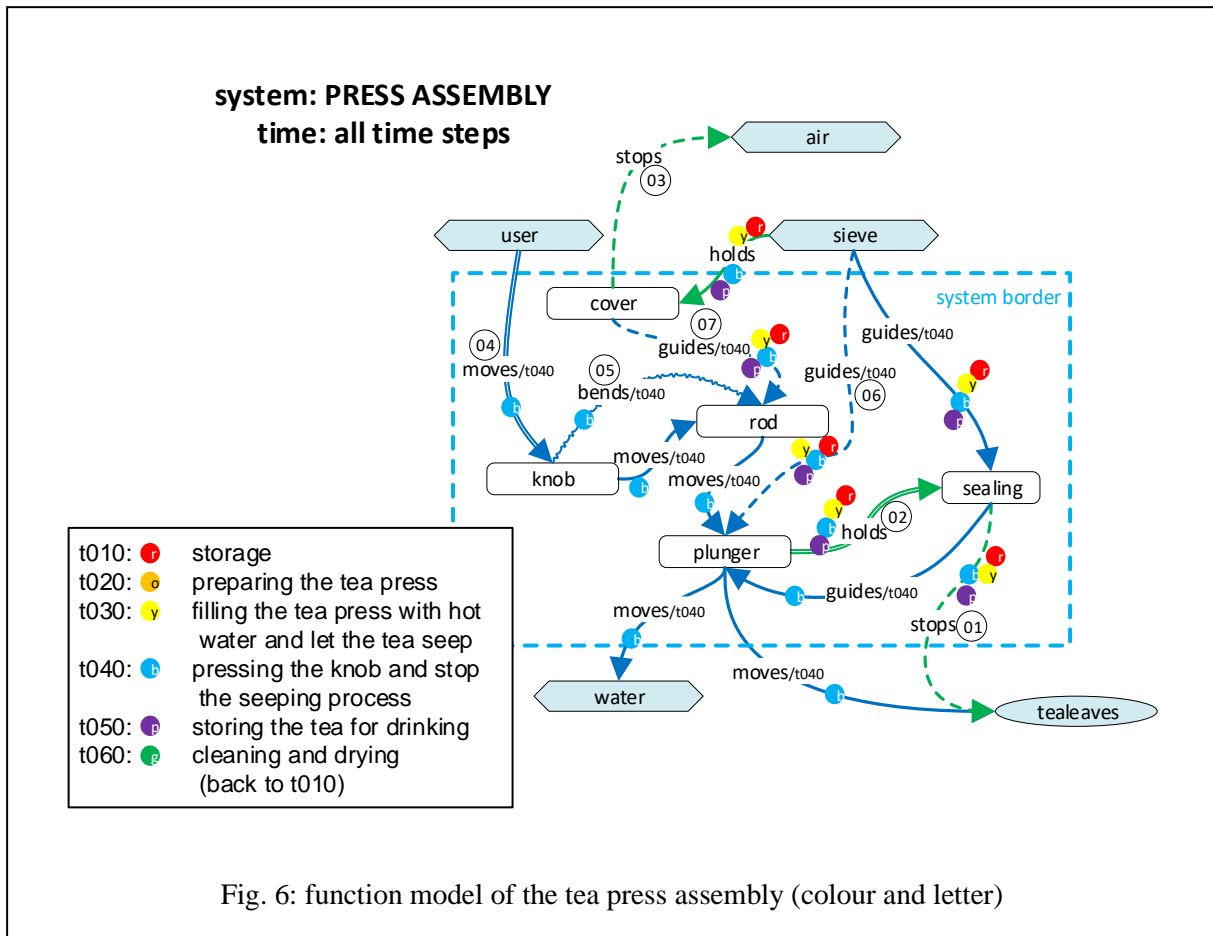


Fig. 3: zooming in and out with function modelling





Now we come back to the time dependency of the function analysis and introduce a way of displaying this in the graphical model. To do this, all time related functions that are associated with the time step of pressing down the knob are displayed in grey (Fig. 5) or blue (Fig. 6). This illustrates the time dependent character of those functions during this step. The perception of the function fulfilment is still visible because the different appearance of the arrows ensure a clear distinction. All functions that are present in prior steps keep their original colour. If further steps should be displayed this could be done by adding a colour or pattern coding and a time stamp. The current time stamp is t040, i.e., the user pressing the knob down. Even for one time the positive effect is present, that the time is clearly visible and the results can be identified. The figures 5 and 6 show this kind of modelling for the step t040. Other possible system times are listed below:

- t010: storage (r: red)
- t020: preparing the tea press (o: orange)
- t030: filling the tea press with hot water and let the tea seep (y: yellow)
- t040: pressing the knob and stop the seeping process (b: blue)
- t050: storing the tea for drinking (p: purple)
- t060: cleaning and drying [back to t010] (g: green)

Now the aim is to find the key problem and this could be done by applying Cause-Effect-Chain or Root-Cause analysis. In [6] Fault Tree Analysis FTA is mentioned but no reference is made to function analysis. Here, for checking the completeness and the consistency of the function analysis, a Fault Tree Analysis is carried out (see figure 7).

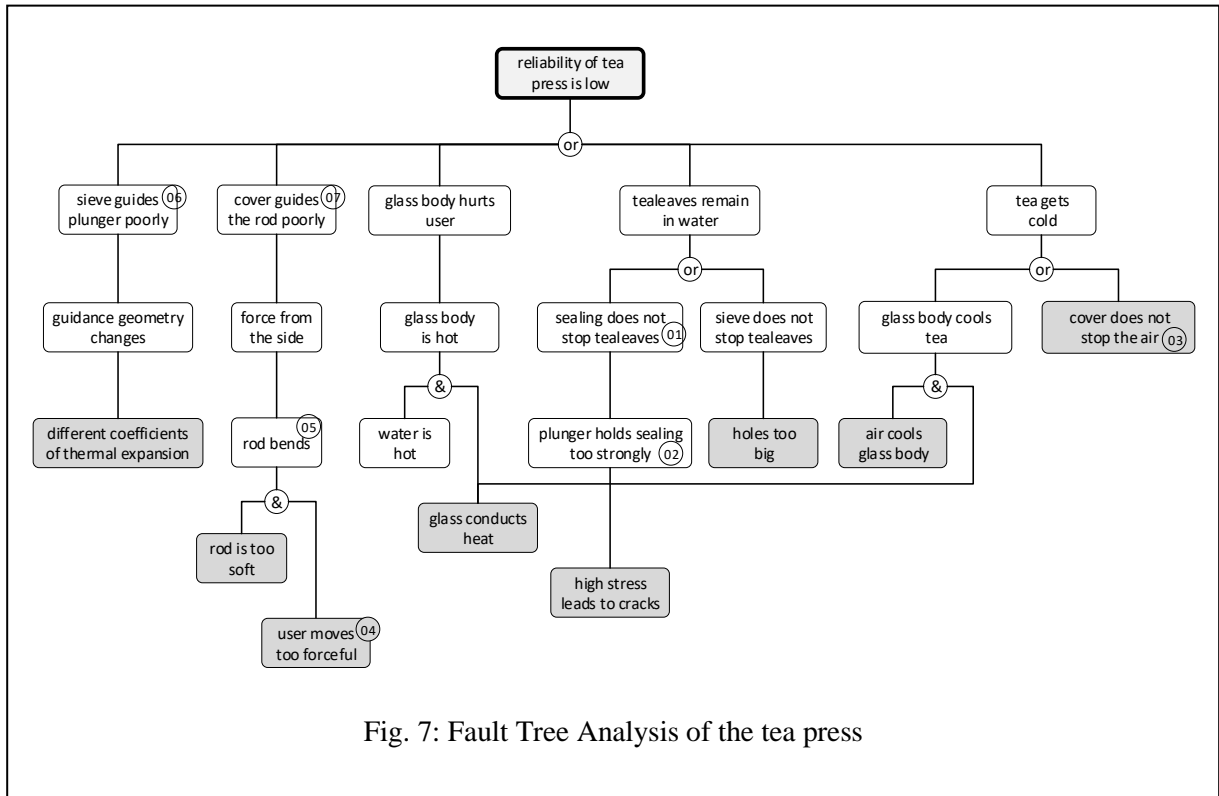


Fig. 7: Fault Tree Analysis of the tea press

All identified harmful, inefficient and excessive functions in the function model should be present within the Fault Tree Analysis (FTA). The introduced numbering links the problems of the FTA with the functions in the function model in figure 5 and 6. In the FTA the problems arise on different levels of the tree and usually there are deeper causes for those problems. The end of a tree path represents the root cause or, in case of more than one, root causes for the problem. Adjusting possible differences of both analysis types lead to checking the models and improved system understanding. The advantages using this kind of modelling can be seen even in this small example system of the tea press. The quality of both analytical tools, the graphical function modelling and the FTA, is improved due to the crosschecking of one with the other. This helps to analyse the problem and facilitates the solution finding. The time related character of functions within the functions analysis is clearly stated and not taken for granted, or even guessed. This way of modelling could be further extended to build a small sequence of several steps within only one function model by using different time stamps without the need of changing the known representation of components. In [5] this is necessary and only three times are referenced. I believe this would not be ideal. Compared to [4], not only a table is provided for the different times but also a schematic which is an improvement. A process flow analysis would require several graphical models to achieve this. The hierarchical structure of function analysis is well known but the explicit presentation helps to visualize this fact. A reduction of the model to the required components reduces the complexity and helps to focus on the main useful function and target of the new system level. It improves the data structuring during the analysis process as well. Therefore, modelling the situation with a time related context within function analysis in such a way improves the visualisation on what level of the system we have problems and second, at what time we have them. The presented single model helps to identify issues and supports the choosing of a problem for further analysis or problem solving.

The process of zooming-in is presented to help people who are not completely familiar with it and can be applied in the other direction (zooming out) as well. Keep in mind, we model the system where issues are and combine other parts to useful assemblies. However, take care, if the problem needs the splitting up into components again because of resources or interaction, a zooming-in is required.

3 Conclusions

The addressed system is a tea press, which is analysed with function analysis and Fault Tree Analysis. The results of the two analytical tools are compared with each other to look for missing functions or inconsistencies. A time-based visualisation using pattern or colour coding in the graphical model of the function analysis is introduced. Modelling the system of the tea press and the perceived problem in such a way leads to the following advantages. A clear and easy to understand structuring of system hierarchy, the associated function models and the time frames to which the models belong. The quality of both models improves due to the crosschecking. If needed short sequences could be built. After an evaluation where and when issues or problems are present within the modelled systems, the user could choose one and move on to the problem solving step.

References

1. A. Lyubomirskiy, S. Litvin, S. Ikovenko, C. Thurnes, R. Adunka: "Trends of Engineering System Evolution (TESE)", Nürnberg, 2018
2. R. Adunka: Begleitbuch zum TRIZ-Basiskurs (Level 1), Nürnberg, 2015
3. R. Adunka: Begleitbuch zum TRIZ-Aufbaukurs (Level 2), Nürnberg, 2013
4. S. Litvin, N. Feygenson, O. Feygenson: "Advanced function approach", Elsevier Ltd., 2011
5. Liu: "An improvement for existing function approach, Krakow, TRIZfest 2017
6. J. Chrzęszcz: "Quantitative approach to Cause-Effect-Chains Analysis", Krakow, TRIZfest 2017

Communication

Communicating Author: j-wessner@t-online.de

TRIZfest 2019

September 11-14, 2019. Heilbronn, Germany

TRIZ TOOLS FOR DISRUPTIVE COST REDUCTION

Simon S.Litvin, PhD

GEN TRIZ, LLC, Boston, 02465, USA

Paper Classification:

- TRIZ-related methods and tools development
- Best practices, business experiences, integration with non-TRIZ methods/tools

Abstract

Cost reduction is one of the most popular targets for innovation. There are multiple approaches to cost reduction, like Target Costing, Just-in-Time (JIT), Lean, Management Audit, Kaizen Costing, etc. However, neither of these methods ensure disruptive cost reduction. Modern TRIZ possesses several tools that allow a dramatic cost reduction. These tools include Key Problems Identification, Trimming, Feature Transfer, Main Parameters of Value Discovery, Function-Oriented Search, etc. The cost of multiple products and technologies on the market is already reduced dramatically as a result of application of TRIZ-based Disruptive Cost Reduction tools.

Keywords: *Disruptive Cost Reduction, Key Problem, Cause-Effect Chains, Trimming, Feature Transfer, Main Parameters of Value, Function-Oriented Search.*

1 Background

1.1 Market Need for Disruptive Cost Reduction

Cost reduction is one of the most popular targets for innovation. The product value is defined as functionality over the cost. The higher the cost, the low the product value is. High costs negatively affects all major business indicators of the business – profitability, return on investment, etc. Moreover, incremental cost reduction does not significantly affect the product value. “In an industry facing massive disruption and change, marginal efficiency savings can no longer guarantee survival and success” [1]. Market disruption occurs when a product addresses non-consumption in an existing product category, i.e. it is available for customers in a way the incumbent products are not [2]. That is why there is an enormous market demand for effective approaches and tools for disruptive cost reduction.

1.2 Known Approaches to Cost Reduction

There are multiple known approaches to cost reduction:

- **Target Costing** is a disciplined process for determining and achieving a full-stream cost at which a proposed product with specified functionality, performance, and quality must be produced in order to generate the desired profitability at the product’s anticipated selling price over a specified period of time in the future. Typically achieved cost reduction – 30-40%.

- **Just-in-Time (JIT)** is a production strategy that strives to improve a business return on investment by reducing in-process inventory and associated carrying costs. To meet JIT objectives, the process relies on signals or Kanban between different points in the process, which tell production when to make the next part. Typically achieved cost reduction – 20-30%.
- **Lean** is a production practice that considers the expenditure of resources for any goal other than the creation of value for the end customer to be wasteful, and thus a target for elimination. Working from the perspective of the customer who consumes a product or service, "value" is defined as any action or process that a customer would be willing to pay for. Typically achieved cost reduction – up to 50%.
- **Management Audit** focuses on results, evaluating the effectiveness and suitability of controls by challenging underlying rules, procedures and methods. Typically achieved cost reduction – 20-30%.
- **Kaizen Costing** is a process of continual cost reduction that occurs after a product design has been completed and is now in production. Cost reduction techniques can include working with suppliers to reduce the cost in their processes, implementing less costly designs of the product or reducing waste cost. Typically achieved cost reduction – up to 20%.

However, neither of these methods ensure a disruptive cost reduction.

1.3 Typical Cost Sources

In order to be effective in cost reduction, it is necessary to understand that there are different components of cost structure. Each of them should be addressed separately. The typical sources of cost are as following:

- Capital cost
- Labour cost
- Operational cost
- Materials, ingredients, components cost
- Energy cost
- Environmental / regulations / legal cost
- Losses and waste
- Depreciation and overhead

1.4 Product Life Cycle Stages that Affect Cost

Another important aspect of cost structure is that each stage of the product life cycle has its own standalone cost structure. Each of them should be addressed separately. The typical stages of product life cycle are as following:

- Development
- Production
- Packaging
- Transportation
- Storage
- Exploitation
- Maintenance
- Recycling / Disposal
- Marketing / Advertising

2 TRIZ General Approach to Disruptive Cost Reduction

There are several wrong assumptions regarding Disruptive Cost Reduction:

- In order to reduce cost dramatically, it is necessary to victimize the quality [2]. For example, Ryanair, the low cost air carrier, is offering to budget travellers much lower costs than KLM or Lufthansa, providing much worse service. Relatively inexpensive but low quality products is a common approach for the markets in developing countries, like India, Brazil, Filipinas, Indonesia, etc. However, the vast majority of products and processes have enough resources allowing significantly reducing cost without deteriorating their quality.
- Adoption of Disruptive Cost Reduction Solutions requires a long time (years) [2]. In fact, if the low cost solution is already exist, its adoption could be swift.
- Developing disruptive cost reduction solutions requires much more time and efforts than incremental ones. Actually, it is opposite: it is easier to develop a couple of breakthrough solutions that reduce the cost dramatically than identifying dozens of incremental solutions.
- Low cost products and technologies are not environmentally friendly. E.g., inexpensive disposable plastic bags represent a huge danger for the nature. In fact, disruptive cost reduction solutions could make products and technologies more sustainable.

In order to achieve a significant / strategic cost reduction, it is necessary:

- Understand fundamental causes of a high cost. A high cost of a product is a result of its specific design and manufacturing process. They in turn consist of some components and operations. These components and operations and their corresponding functions are based on some specific action principles. Addressing the fundamental causes of a high cost, it is possible allowing making a cost reduction process focused on right targets.
- Formulate non-obvious problems that are intentionally leading to reducing the significant part of the cost. For instance, how to eliminate from the system some costly component without losing its functionality?
- Search for existing cost effective solutions from other industries and then adopt these solutions to address identified cost reduction problems.
- Identify right targets for innovation focusing the product cost on achieving unsatisfied market needs and reducing the cost serving for less important parameters of customer value.

Basing on the definition of a system's value (functionality over the cost), TRIZ recommends two major ways for Disruptive Cost Reduction:

- Targeting investment more precisely to maximise strategic advantage (increase "good costs").
- Cutting out the low performing business and inefficient operations ("bad costs") that waste resources and hold back returns.

3 TRIZ Tools for Disruptive Cost Reduction

Modern TRIZ offers several tools that allow reducing cost dramatically. They all were developed within last 30 years by authors from IMCorp, PVI, GEN3 Partners, and GEN TRIZ. They

include Cause-Effect Chains Analysis, Key Problems identification, Trimming technique, Feature Transfer, Function-Oriented Search, Resources Audit, and Main Parameters of Value (MPV) discovery.

3.1 Cause-Effect Chains Analysis

Cause-Effect Chains Analysis (CECA) is a GEN TRIZ analytical tool that identifies the Key Problems of the analyzed engineering system. This is accomplished by building Cause-Effect Chains of disadvantages that link the Target Problem to its fundamental causes. If the Target Problem is an excessive cost, CECA allows to identify the deep causes of the high cost. By addressing these causes (Key Problems) one can achieve a disruptive cost reduction.

The idea of CECA is instead of directly addressing high cost issues, first identify underlying fundamental causes of this high cost. CECA approach is well known in the engineering community (Root Cause Analysis, Fish-bone Diagrams, etc.). However, within TRIZ it was furnished with specific rules and recommendations that make it effective, reliable and repeatable.

3.1.1 Case Study 1. Coffee Bag

Initial situation: Coffee bag has small pores to retain the small coffee particles, see Fig. . These small pores restrict the easy flow of water inside the bag. Hence, the extraction of coffee takes more time. To overcome the problem of slow coffee extraction, more coffee is filled in the bag, resulting in high cost of the coffee bag. The project goal is to reduce the cost of the coffee bag.



Fig. 1. Coffee bags

Cause-Effect Chain Analysis identified two key disadvantages, see Fig. :

- Excessive number of Ca & Mg ions in water
- Paper pores are too small

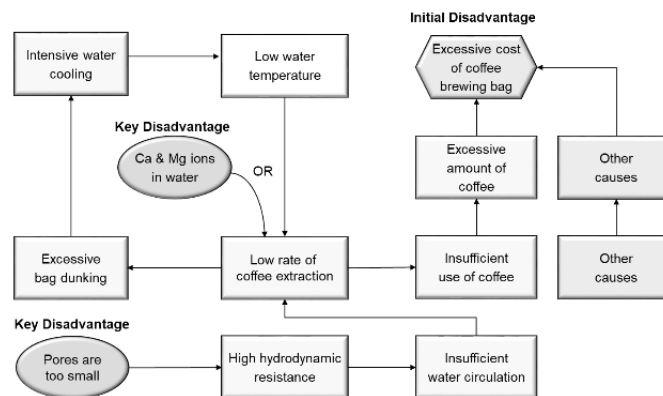


Fig. 2. Cause-Effect Chain Analysis

The key disadvantage “Excessive number of Ca & Mg ions in water” was reformulated into the key problem: “How to remove Ca & Mg ions from water?” The solution of this problem was identified in technologies database - application of ionites. We proposed to add ionite particles into the coffee bag, see Fig. . These particles absorb Ca and Mg ions during fraction of second. Ionite particles are low cost and do not affect the flavor or chemical composition of the extracted coffee. Ionite particles are very effective in reducing the Ca and Mg ions from the water thus dramatically increasing the coffee extraction rate. Results:

- Amount of coffee in the bag reduction – 50%
- Product cost reduction – 40%

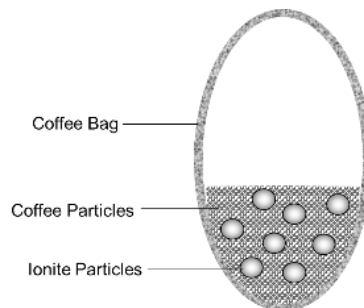


Fig. 3. Coffee bag with ionite particles

3.2 Trimming

Trimming [3] is a GEN TRIZ analytical tool for removing (trimming) from the system certain components and redistributing their useful functions among the remaining system or super-system components. Trimming is a major TRIZ tool for breakthrough cost reduction. The idea of Trimming is to completely eliminate one or more components of the product or operations of the process with their corresponding costs without any deterioration of the product / process / service functionality.

Trimming sounds counter-intuitive to common engineers because each component of the product or process was design to perform some important function. How can this component be eliminated without losing functionality? Trimming achieves this challenging goal by redistribution of functions of the trimmed component between the rest of the components and the super-system. This approach allows dramatically reducing the cost without victimizing the product quality.

Trimming technique is furnished with an algorithm of Trimming and recommendations on how to select the component to be trimmed; how to select the most effective option of trimming; and how to distribute functions between the rest of components and super-system.

3.2.1 Case Study 2: Low Fat Peanut Butter

Initial situation: In order to produce Low Fat Peanut Butter it is necessary to substitute 40% of peanut butter (highly viscous liquid) with corn syrup and soy proteins (thin powders). It was a very challenging task that was performed in three steps using Auger Mixer, Disc Mills and Jet Mixer, see Fig. . The capital cost and production footprint were too high and production rate is too low.

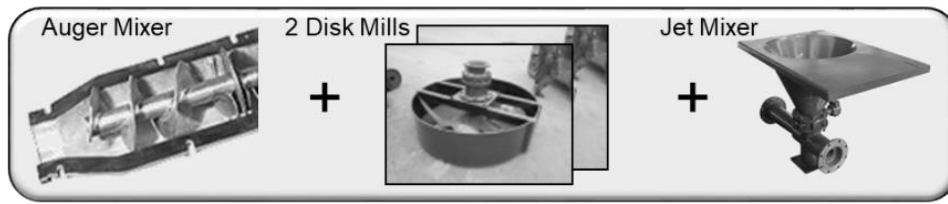


Fig. 4. Existing technology

Trimming problem: How to make the auger mixer to perform functions of disk mills and jet mixer

GEN TRIZ problem solving tool applied – Function-Oriented Search:

- Function – to mix ingredients (peanut butter, corn syrup and soy proteins).
- Generalized function - to move powder particles relative to viscose liquid.
- Leading industrial area – concrete production.
- Identified enabling technology - pseudo-liquation by means of vibration

Solution: We proposed to use Resonance Vibrating Auger Mixer with the frequency of vibration equal to own frequency of toner particles, see Fig. :

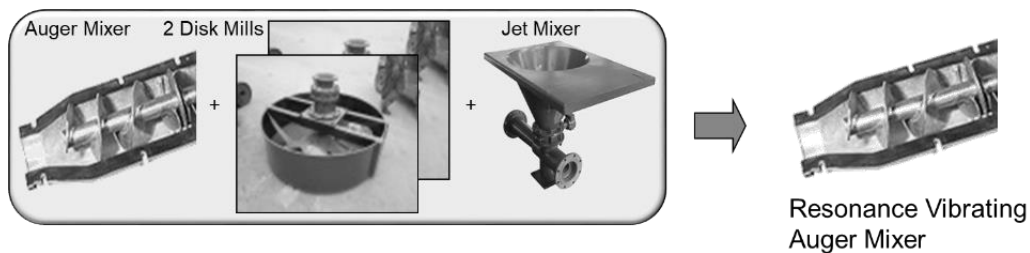


Fig. 5. Solution of Trimming problem: Vibrating Mixer

Business impact:

- Four pieces of equipment were substituted with one
- Productivity increase - 2.5 times
- Footprint reduction - more than 3 times
- Capital cost reduction – more than 40%

3.3 Feature Transfer

All Engineering Systems have advantages and disadvantages. Is it possible to create a system that preserves the advantages of the original system while eliminating its disadvantages by transferring the advantage form another system?

Feature Transfer [4] is a GEN TRIZ's analytical tool for improvement of one engineering system by transferring relevant features from another (alternative) engineering system. Alternative engineering system is one that has the same function as that of initial engineering system, but its advantages and disadvantages are opposite to initial engineering system.

Feature Transfer is different from “hybridization” because it instructs how to transfer the “How” from one engineering system to another, rather than transferring the “What”. In other words, it is the feature that should be transferred (such as properties, characteristics, etc.), rather than the specific design (components, elements, materials, etc.)

Feature Transfer significantly reduces the required investment because the Alternative System already has the characteristics desirable for the initial Engineering System. The tool yields new Key Problem statements, and leads toward powerful solutions. The outcome of Feature Transfer is a set of Key Problems related to transferring features from one system to another.

Feature Transfer alleviates the requirement of additional proof that desired characteristics can be achieved, since they already exist in a complementary system. Feature Transfer is an effective tool for cost reduction due to focusing on improving the less costly system.

3.3.1 Case Study 3: Peat Ridger

Initial Engineering System: Bulldozer Peat Ridger, see Fig. :



Fig. 6. Peat ridger

Main function: To move peat during harvesting

Challenge: Since the surface of the peat field is uneven, the ridger’s blade cuts into wet peat, which decreases quality of the final product. The blade also loses a significant amount of dry peat by skimming over it.

Project Goal: To develop a low cost peat ridger that could collect all dry peat and not cut wet peat.

Alternative System: Vacuum Peat Collector, see Fig. :



Fig. 7. Vacuum peat collector

Both systems have symmetrical advantages and disadvantages:

- Bulldozer ridger: simple and inexpensive, but non-selective
- Vacuum peat collector: highly selective, but very expensive and very low productive

Feature of Vacuum Peat Collector that enables high quality of the product: Flexibility of the working tool (airflow instead of rigid blade).

Feature Transfer problem: How to combine airflow with the bulldozer blade to provide both selectivity and productivity?

Solution: We proposed a hollow perforated bulldozer blade, connected to a compressor. The blade collects majority of the peat, and airflow from perforation collects dry peat from uneven field surface, see Fig. :

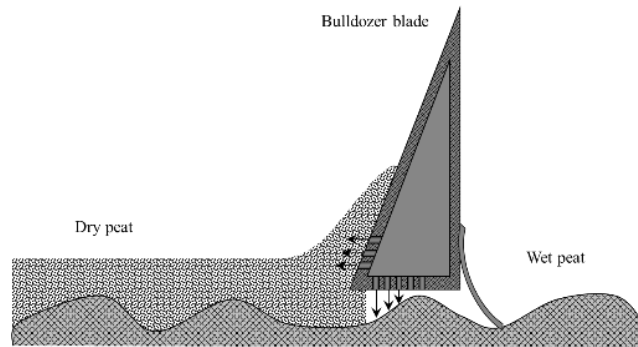


Fig. 8. Bulldozer blade + air cushion

Business Impact:

- High quality of collected peat
- Cost of the new peat ridger is close to the cost of the bulldozer one

3.4 Function-Oriented Search

GEN TRIZ's Function-Oriented Search (FOS) [5] is a problem-solving tool that uses functional criteria to help identify existing technologies in leading areas of science and engineering. One of major challenges of innovation is a contradiction: the solution should be disruptive in order to assure significant improvement of the product/process; however, the solution should be already proven in order to reduce time of implementation. Function-Oriented Search (FOS) resolves this contradiction and changes innovation paradigm by offering already existing solutions or technologies rather than inventing new ones.

To apply FOS, we begin by identifying the functions in the system that need to be improved. These specific functions are then translated into generalized functions that will become the targets of an external search.

Industries face similar engineering challenges, but those similarities are not readily obvious, because the industries where they appear may be completely different from each other. The focus of Function-Oriented Search is on relevant industries or knowledge domains that face functionally similar challenges to the client's system. Typically, the most rewarding domains to explore are those industries where:

- The function is absolutely critical to the survival of the industry, and/or
- The function is subjected to much harsher conditions and requirements than in the client's system.

Under these conditions, there is a greater likelihood that investment already has been focused on solving this functional challenge. Adapting existing technologies is easier, more reliable, and requires fewer resources (labor, capital, and time) than inventing new technologies and

their applications. FOS removes the industry-specific limitations of a potential solution and uncovers possibilities regardless of the source industry. It allows capitalizing on investment made in other industries.

There is a new category of problems – Adaptation Problems that being addressed allow to effectively and efficiently transferring a solution from the Leading Area to the initial industry.

FOS allows finding very practical solutions that enable disruptive cost reduction. FOS also breaks psychological barriers for acceptance of new technologies eliminating the most challenging issue of innovation – “prove me that your solution will work” because it already works.

FOS Algorithm, see Fig. :

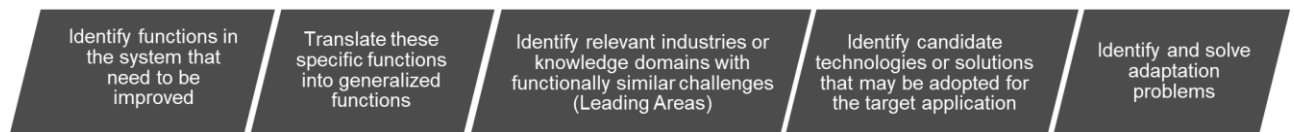


Fig. 9. FOS algorithm

3.4.1 Case Study 4: Computer Chips Manufacturing

Initial situation: A process includes the coating of a rotating wafer by a thin layer of photo-resist (viscous polymer). The process has the disadvantage: bubble creation during the photo-resist dispensing, that worsening film properties, see Fig. 10. The waste level due to this problem is up to 20%.

Therefore, it is necessary to reduce operating cost dramatically by eliminating bubbles formation during photo-resist dispensing.

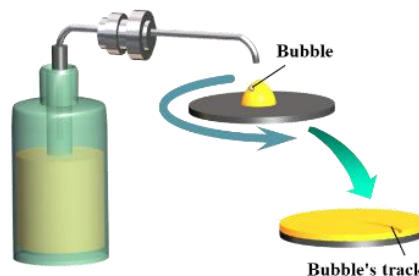


Fig. 9. Coating of the wafer by photo-resist

TRIZ tool for problem solving - Function-Oriented Search.

Specific function to be improved: To remove bubbles from photo-resist during its dispensing.

Generalized function: To control bubble formation in liquids flows.

Leading Industries:

- Blood transfusion
- Scuba diving
- Champagne wines production

Solution (identified technology from Champagne industry): We recommended replacing the regular seat valve, creating turbulence, see Fig. , with the ball valve that prevents a liquid flow turbulence resulting in preventing bubbles, see Fig. :

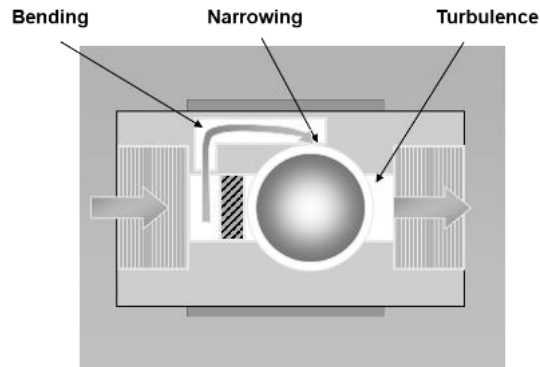


Fig. 11. Seat valve creates polymer flow disturbance

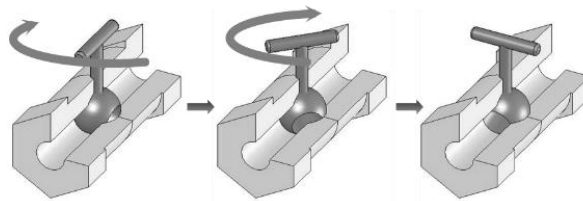


Fig. 12. Ball valve

Business Impact:

- Waste wafers level – 0%.
- Annual cost savings – more than \$20M

3.5 Main Parameters of Value Discovery

Today there is no direct connection between business challenges and underlying technical problems. Executives of industrial companies are operating with business categories like annual revenue, profit margin, market potential, market share, return on investment, etc. There is an obvious need for effective methodological tools that are capable to connect business challenges and specific technical problems of products and technologies.

Main Parameters of Value (MPV) Discovery [6-8] is a GEN TRIZ's problem solving tool that addresses the above mentioned business need. MPV's are the critical features that differentiate products and drive customer-purchasing decisions. A disciplined focus on MPV's helps ensure that scarce R&D innovation resources are focused exclusively on improving the features that matter most to customers, as opposed to improving all product features. That allows reducing the cost of the product or technology dramatically. It also allows targeting investment more precisely to maximize strategic advantage (increase "good costs").

MPV Discovery approach includes two sets of tools – Voice of the Customer (VOC) and Voice of the Product (VOP). VOC is based on traditional marketing tools, such as market surveys, field observations, focus groups, etc. VOP is based on TRIZ tools, like Function Analysis, Trends of Engineering System Evolution, etc.

3.5.1 Case Study 5 – Electrical Shaver

Initial situation: A company that is producing electrical shavers is losing market share. The shavers market is highly saturated and competitive. The company's shavers have high quality, but high price tag (\$120-180), having marginal performance differences with competitors.

Initially formulated business challenge: How do we make the electrical shaver a market winner?

Voice of the Customer identified three parameters:

- Shaving Effectiveness/Cleanliness
- Skin Protection
- Low Price

Preliminary analysis: The shaving effectiveness is quite satisfactory for all shavers on the market. The skin protection is also satisfactory provided by so-called "floating" blades. Conclusion: It is necessary to identify some other new MPV (significant competitive advantage).

New MPV discovery:

Analysis of market niches and typical occasions:

- Frequent travelers
- Elderly or disabled people with hand tremor
- People with fast growing hair
- People that need to shave urgently (before an important business meeting or date)

Revealed new MPVs (specific parameters that are important for all these categories of users):

- Compactness
- Low weight
- Absence of need for charging

Solution: The compact card-sized shaver that can be used on demand, see Fig. :



Fig. 13. Compact shaver

The price of the new shaver is \$19-54. Business impact: more than \$50M annual revenue.

4 Results

Basing on the above mentioned and some other TRIZ tools and approaches GEN TRIZ was able to develop several products, services and technologies with dramatically reduced cost,

which allowed our clients to be competitive on the market. In many instances, the achieved cost reduction was exceeded client's expectations several times. That is why we developed the special set of success criteria for cost reduction:

- Success: the client's objective for cost reduction is achieved.
- Great Success: the client's objective for cost reduction is exceeded up to 2 times.
- Home Run: the client's objective for cost reduction is exceeded more than 2 times.

5 Conclusions

- Cost Reduction is a major direction for Innovation, but even an incremental cost reduction is very challenging.
- Disruptive cost reduction allows introducing to the market a product that addresses non-consumption in an existing product category, i.e. it is available for customers in a way the incumbent products are not.
- It is possible to reduce cost of products and processes without quality deteriorating.
- Adoption of Disruptive Cost Reduction Solutions could be swift.
- It is easier to develop a couple of disruptive cost reduction solutions than identifying dozens of incremental solutions.
- Cost reduction solutions could make products and technologies more sustainable.
- GEN TRIZ methodology possesses several powerful approaches and tools enabling Disruptive Cost Reduction.
- Trimming technique allows to completely eliminate one or more immanent components of the product or operations of the process/service with their corresponding costs
- Cause-Effect Chains Analysis (CECA) identifies underlying fundamental causes of this high cost (Key Problems) instead of directly addressing the high cost issues.
- Feature Transfer allows transferring the features of functionally effective but expensive product or process to the existing less costly one.
- Function-Oriented Search (FOS) focuses on identification of some existing functionally similar but significantly less expensive technologies in distant areas.
- MPV Discovery (Voice of the Product) allows identifying latent parameters of value and re-evaluating the over-estimated parameters. It allows product cost reducing by ignoring the parameters of value that are not main and concentrating efforts on MPV only.

References

1. O'Hearn S. "More for Less: Five Steps to Strategic Cost Reduction". www.pwc.com/gx/en/insurance/publications/firing-on-all-cylinders-five-steps-to-strategic-cost-reduction.pdf
2. Honey J. "What is Disruptive Pricing?" www.quora.com/What-is-disruptive-pricing
3. S. Litvin, A. Lyubomirskiy, M. Waldman. "Trimming: A Fast, Efficient Method for Improving Manufacturing Processes". DE-Vol. 109, Recent Advances in Design for Manufacture (DFM), ASME-2000, p. 135
4. S. Litvin, V. Gerasimov. "Development of Alternative Technical Systems (Feature Transfer)". Design Studies Magazine. Vol. 12, № 4, 1991
5. S. Litvin. "New TRIZ-Based Tool – Function-Oriented Search". ETRIA Conference TRIZFuture 2004. November 2-5, 2004, Florence, Italy.
6. J. Sims, S. Kogan. "Bringing Innovation to the Innovation Process". Industry Week, USA, September 7, 2005.

7. M. Treacy. “Does the Voice of the Customer Matter?” Advertizing Age, USA, 2005.
8. S. Litvin. “Business to Technology – New Stage of TRIZ Development”. TRIZ Future 2005, Graz, Austria, November 2005.

Communication

Communicating Author: slitvin@gen-triz.com

TRIZfest 2019

September 11-14, 2019. Heilbronn, Germany

TRIZ TOOLS FOR EFFECTIVE ROADMAPS

Kirill Domkin, Oleg Gerasimov, Georgy Severinets

DSG consulting, Moscow, 440000, Russia

Paper Classification:

- Best practices, business experiences, integration with non-TRIZ methods/tools

Abstract

As known, roadmaps tend to play ever increasing and important role in the innovative development of a company. Systematic using of TRIZ tools can increase the effectiveness of project implementation. The paper presents a basic roadmap with TRIZ tools. The program of including TRIZ tools into a Roadmap is shown.

Keywords: *Roadmap, company, TRIZ, project.*

1 Roadmaps in innovative development of the company

Usually companies plan projects. It is impossible to complete work successfully without planning. A good plan is always based on well elaborated strategy. For its realization it is necessary to create and use a Roadmap. Roadmapping is a well-known tool, which defines the use of new and emerging breakthrough technologies for product development.

The Roadmap is the short- or long-term working plan on developing a product. Most often it is made for a new version of already known product, which includes changes which are expected by consumers. The roadmap consist of means, approaches or ways, which are necessary to achieve goals. As a rule, the "Roadmap" concept applies to a new product, process or technology developed. Such roadmap has three directions of use:

- it helps to combine the requirements and technologies which are necessary for requirements satisfaction;
- it helps with technology development forecasting;
- it creates basis for technical development, planning and coordination.

In fact, the flow in a roadmap defines alternative technologies of "road" (path) for effective goals achievement.

A completed roadmap has one realistic goal and several alternatives of its realization. The priority is given to the most effective and efficient alternative; other alternatives can be applied in case of force majeure.

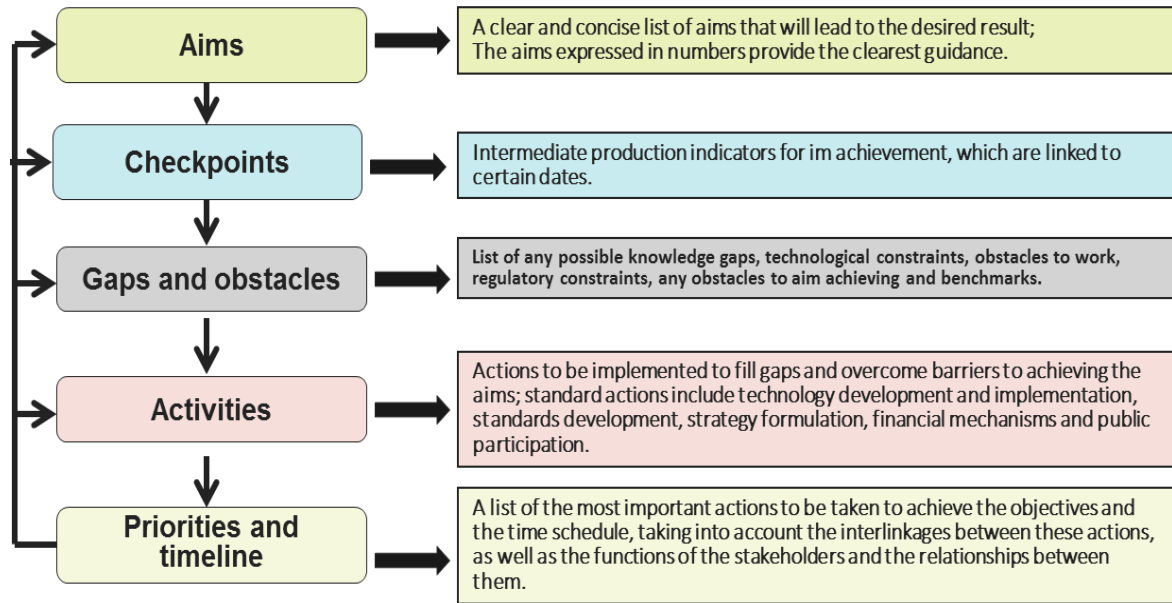


Fig. 1. Key elements of the classical approach to a Roadmap

2 Roadmap and TRIZ tools

It appears that companies can considerably enhance both planning and execution of their projects by creating Roadmaps. Recently the trend has been observed that demands for training of companies' management and staff on the development of roadmaps grow.

A unique roadmap should always be developed for each project.

One company asked to help them to develop a "Roadmap" of the project as many employees experienced difficulties with project execution. It was a new task called "The roadmap - for the roadmap."

The processes of execution and control usually do not create problems, but with goal-setting all is not simple. For example, in a situation when a task must be set for subordinates exactly, for example, to reduce production cost of a product. The headache begins with asking well-known question: What to do?

Here TRIZ comes to the rescue.

TRIZ helps to understand and answer the following question: Why are difficult problems difficult?

- There is a psychological inertia.
- The task faces a contradiction.
- A solution is in other professional domain.
- The problem should be solved with attraction of new knowledge.

One of the best tools and technologies for goals achievement - TRIZ can be included in the roadmap. Figure 2 shows the general Roadmap with TRIZ tools.

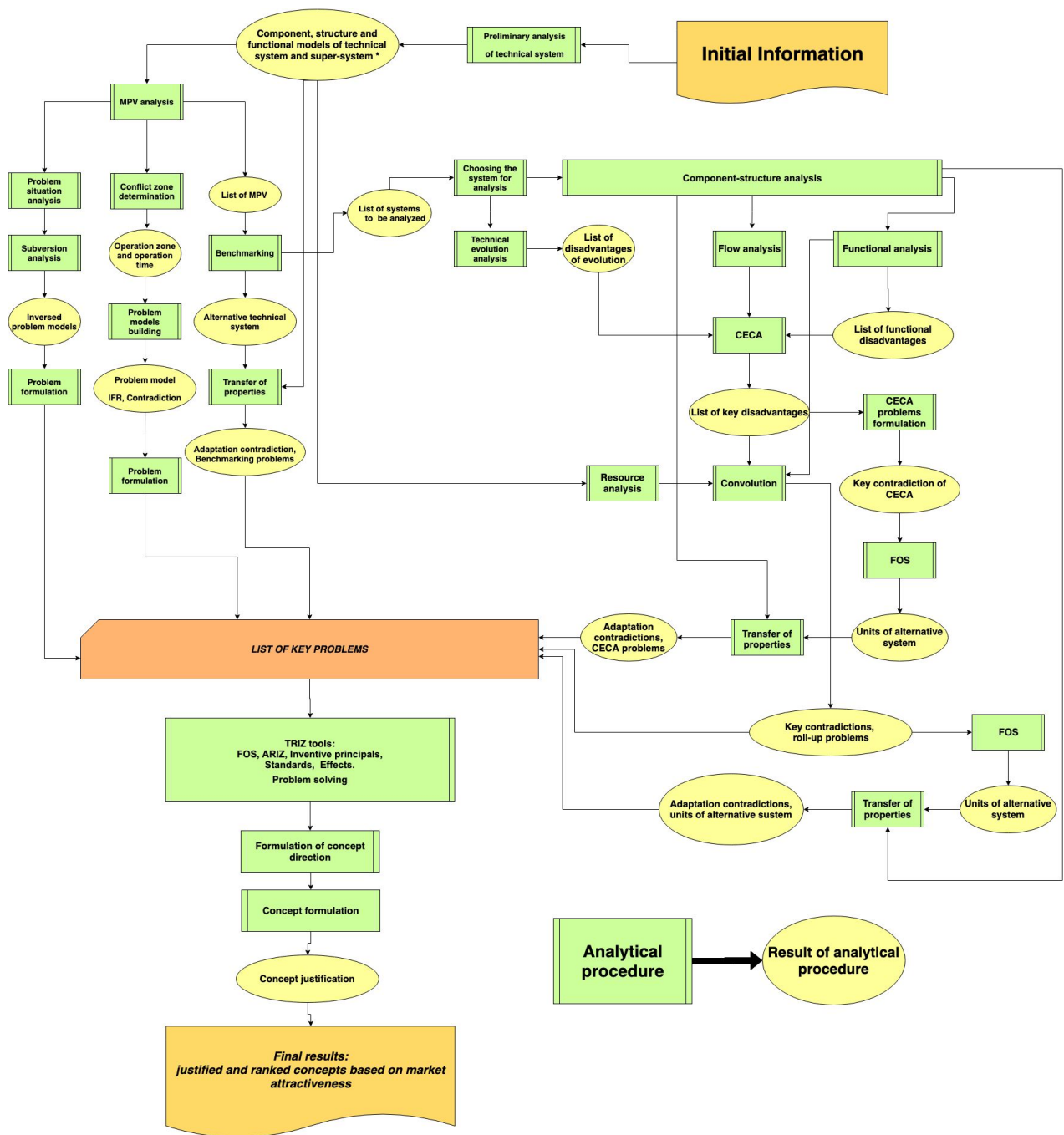


Figure 2. General roadmap with TRIZ tools.

Figure 3 shows the example of specific roadmap for the project: Elimination of oil from nitrogen at metal pulverization. The process of creating of “a Roadmap of a Roadmap” was as follows:

1. Roadmap (A timeline consisting of time intervals which are necessary for performance of actions for Roadmap construction; Checking points at each stage of Roadmap construction; producing of Roadmap).
2. Purpose of Roadmap (Is the main document for strategy realization which Reflects a mission and the purposes of the project; Shows the main directions of actions for key team players; Synchronizes participants of the project; Roadmap Elements; The project

Purposes — for what are made actions; Audience — those for whom everything is created; Team — those who implement the project.) Necessary actions and actionees of Roadmap (Visual elements are schemes of the movement in the form of tables, schedules, maps, drawings).

3. Concepts of a System and a Technical system.
4. Laws of Technical System Evolution (Evolution patterns and "Evolution Trees" - as tools, the Technique of work with Patterns and "Trees").
5. Function (Functional analysis; The Analysis of function in parameters, the Analysis of function at cost).
6. Cause-Effect Chain Analysis (CECA) (Technique of creation of Cause-Effect Chains of Negative Effects; algorithm and rules of Cause-Effect Chains creation).
7. Function Oriented Search (FOS) (A technique of work with FOS).

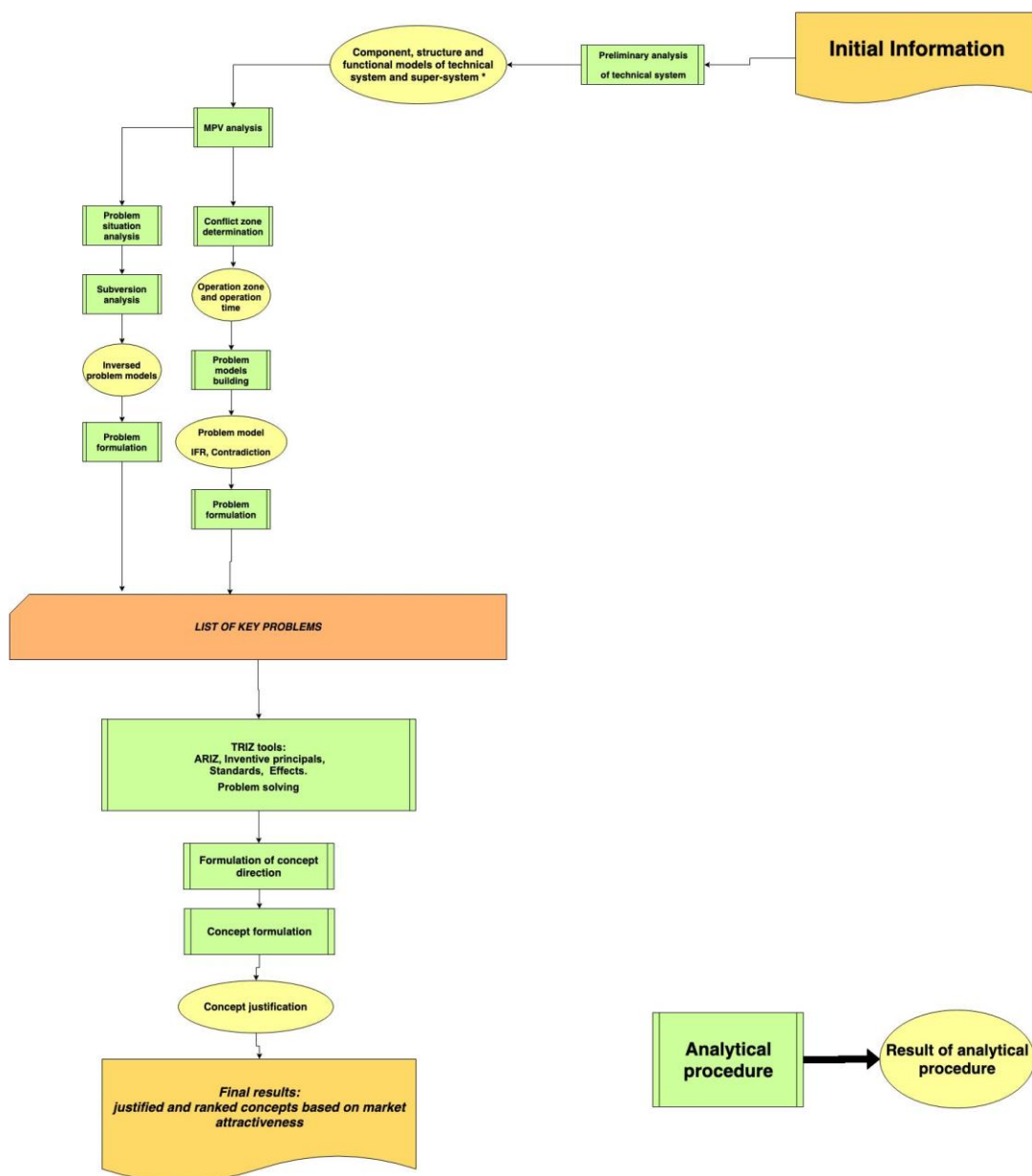


Fig. 3. Roadmap for the real project with selected TRIZ tools: Elimination of oil from nitrogen at metal pulverization

3 Conclusions

TRIZ methods and tools can be used effectively for developing Roadmaps in all activities of the Company.

Positive conclusions made by the clients after the course completion:

1. The "Roadmap" created with the use of the gained knowledge has strict logic, and communications between stages are logical and clear, and influence of subjective factors is generally eliminated;
2. New tools which were used for "Roadmap" creation are very practical and effective, including Function Analysis, Cause-Effect Chain Analysis, Function-oriented Search and the Laws of Technical System Evolution (Evolution patterns);
3. Application of the updated Roadmaps helped to reveal shortcomings of initial technical planning of divisions, the insufficient analysis and use of new technologies as well as a lack of cross- and multi-disciplinary cooperation.
4. The updated Roadmap helps new employees to understand quickly the history and current state of company activities.
5. The combination of the updated "Roadmap" and evolution trees and patterns will play an important role in innovation projects.

References

1. Altshuller G.S., Zlotin B.L., Zusman A.V. Poisk Novyh Idei: Ot Ozareniya K Technologii (Teoriya I Praktika Resheniya Izobretatelskih Zadach), Kishinev, "Kartya Molodnyavske", 1989.
2. Shpakovsky N.A. TRIZ. Tree of Technology Evolution Ways of New Business Opportunities. ISBN 978-5-91134-389-7.
3. Phaal, R., Farrukh, C. and Probert, D. (2001). Technology Roadmapping: linking technology resources to business objectives. Centre for Technology Management, University of Cambridge.
4. Laube, T. and Abele, T. (2005). Technologie-Roadmap: Strategisches und taktisches Technologiemanagement. Ein Leitfaden. Fraunhofer-Institut Produktionstechnik und Automatisierung (IPA), Stuttgart, Germany. ISBN 3-8167-7186-6
5. Garcia M. L., Bra O. H. (1997). Fundamentals of Technology Roadmapping. Strategic Business Development Department, Sandia National Laboratories.
6. <https://www.entrepreneur.com/article/83000> - Creating a Technology Road Map

Communication

Communicating Author: Kirill Domkin, ego85@mail.ru

Proceedings of the 15th MATRIZ TRIZfest-2019 International Conference

September 11-14, 2019, Heilbron, Germany

Organized by the International TRIZ Association – MATRIZ

Editors: Valeri Souchkov, Oliver Mayer

The collection of papers «**Proceedings of TRIZfest 2019 International Conference**» is intended for TRIZ specialists and users: academics, engineers, inventors, innovation professionals, consultants, trainers, teachers.

The present book of Proceedings includes papers related to the research and development of TRIZ, best practices with TRIZ, cases of practical application of TRIZ, and issues related to TRIZ training and education.

All presented papers are double-blind peer-reviewed.

© Copyright 2019: The International TRIZ Association - MATRIZ

ISSN: 2374-2275

ISBN: 978-0-578-62617-8

Published by the International TRIZ Association - MATRIZ

8946 Wesley Place, Knoxville, TN 37922 USA

www.matriz.org